

PARTS LIST:

1	Extreme HD Rear Bumper	2	License Plate Plugs
1	Driver/Left Mounting Bracket	2	10mm x 35mm Double Bolt Plate
1	Passenger/Right Mounting Bracket	4	10mm x 30mm OD x 2.5mm Flat Washers
6	15.5mm x 25mm OD x 2mm Foam Washers	4	10mm Nylon Lock Nuts
6	20mm x 10mm Foam Spacers	4	10mm Plastic Retainers
6	Plastic Covers	12	4mm x 15mm Self Tapping Screws
6	Retaining Caps	10	Wire Ties
1	Sensor Cover Kit	1	4mm Hex Wrench

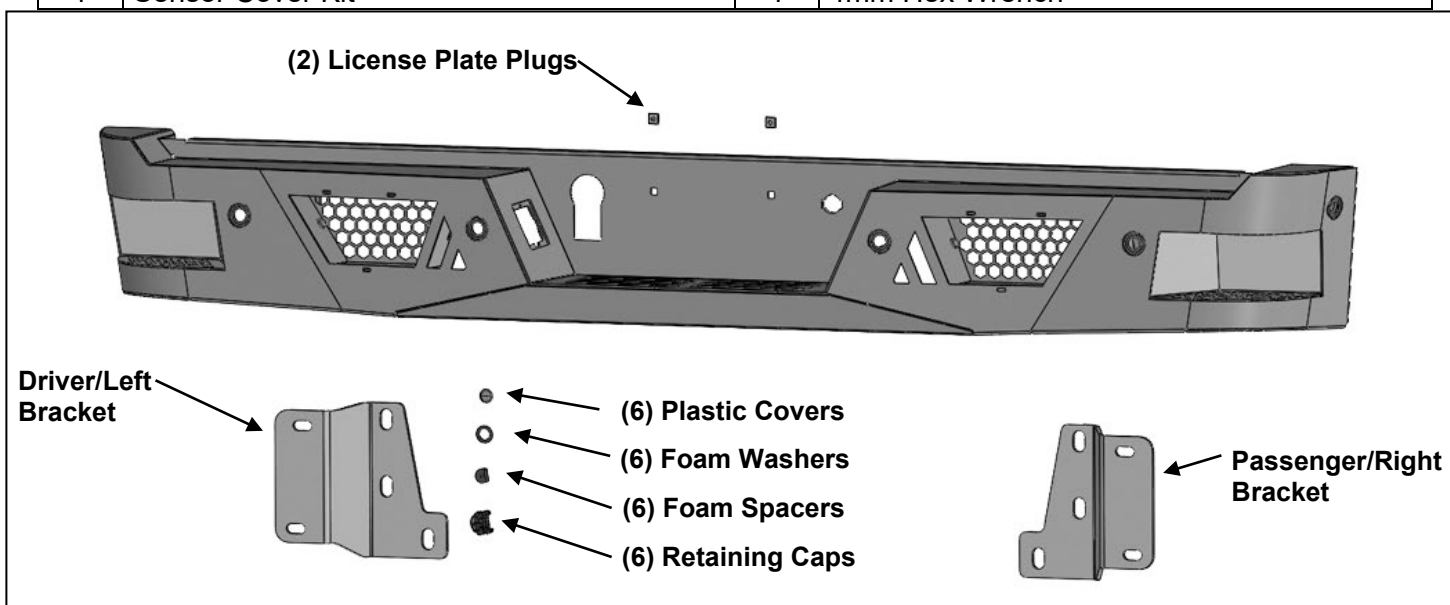

PROCEDURE:

REMOVE CONTENTS FROM BOX. VERIFY ALL PARTS ARE PRESENT. READ INSTRUCTIONS CAREFULLY BEFORE STARTING INSTALLATION. BUMPER IS HEAVY, ASSISTANCE IS RECOMMENDED TO AVOID POSSIBLE INJURY OR DAMAGE TO THE VEHICLE.

IMPORTANT: OEM BUMPER REINFORCEMENT USED WITH "STANDARD" TOW PACKAGE WITHOUT RECEIVER HITCH CANNOT BE REINSTALLED. OE INTEGRATED "HD" HITCH, "MAX DUTY" HITCH AND MOST AFTERMARKET RECEIVER HITCHES REQUIRED FOR TOWING.

1. Remove the license plate from the bumper, (**Figure 1**). Unplug all wiring harnesses leading to the rear bumper and move harnesses away from bumper, (**Figure 2**). **NOTE:** Bumper is designed to be compatible with larger 7-wire universal trailer harness plug only.
2. Place blocks or jack stands under the bumper to support it during mounting bolt removal. Once the bumper has been safely supported, remove the hardware attaching the bumper assembly to the end of the frame, (**Figure 3A, 3B & 4**). On models with "Max Duty" separate receiver hitch, do not remove hitch from bottom of frame. **WARNING!** Assistance is required to hold the bumper in place during hardware removal.
3. Disassemble the bumper to remove sensors, (if equipped), license plate lights, trailer plug and wiring harness, (**Figure 5**). On models with "HD" tow package with integrated hitch, remove hitch/bracket assembly from back of factory bumper.
4. **Determine if the vehicle is equipped with sensors. NOTE:** Sensors, (if equipped), must be installed before attaching Bumper to the vehicle.

Models without bumper sensors:

 - a. Select the included (6) Sensor Covers.
 - b. From the front of the bumper, push Covers into sensor mounting holes, (**Figure 6**).

Models with bumper mounted sensors:

- a. Remove the small factory sealing washer from the sensor. Attach the provided larger (1) Foam Washer to the front of the sensor, **(Figure 7)**.
 - b. Push the sensor in from the back of the Bumper until it is flush with the sensor mount.
 - c. Attach the adhesive side of (1) Foam Spacer to (1) Retaining Cap. Push the Retaining Cap onto the sensor mount until it locks onto the mounting sleeve, **(Figure 8)**.
 - d. Repeat the previous steps to attach each sensor to the back of the Bumper.
- 5. LED light installation at ends of bumper (sold separately).**
- a. Insert light into opening and up to mounting slot. Check for clearance between front and back of light. If necessary, remove the screen from the back of the opening for additional clearance or access to light.
 - b. Follow manufacturer's instructions to attach light to slot in the top of opening and to connect to electrical system.
 - c. Repeat the above steps for passenger side light installation.
- 6. Reinstall the license plate lights, trailer plug, and wiring harness. Insert the (2) License Plate Plugs into the (2) holes in the upper step area, (Figure 9). NOTE: Use a flat blade screwdriver to carefully pry out the metal clips on the trailer plug to grab the edge of the opening. If needed. Use the included Wire Ties to secure the wiring harness to the bumper as necessary. Plug sensors, if equipped, and license plate lights into bumper wiring harness.**
- 7. Use a small flat blade screwdriver to pry the star washers from the bolt plates used to attach the factory bumper to the end of the frame, (Figure 10). NOTE: Depending on the tow package, some models use a triple bolt plate, other models use a double bolt plate.**
- 8. Select (1) 10mm Double Bolt Plate. Insert the Bolt Plate into the mounting plate on the Driver/Left side on the bumper and thread (2) 10mm Plastic Retainers onto the threads to hold the Bolt Plate in place, (Figure 11). Repeat this Step to attach (1) 10mm Double Bolt Plate to the Passenger/Right side.**
- 9. Determine towing package supplied with vehicle:**
- Models with "standard tow package" without HD receiver below bumper and models with "Max Duty," separate frame mounted receiver hitch below bumper.**
- a. Insert the factory double bolt plate into the Mounting Bracket and out through the slots. Reuse the factory nuts to attach the Mounting Bracket to the frame, **(Figure 12)**. Do not tighten hardware.
 - b. Repeat the previous Steps to install the Passenger/Right Mounting Bracket and factory bolt plate.
- Models with "HD" tow package with integrated receiver hitch built into bumper and brackets.**
- a. Insert the factory triple bolt plate into the Mounting Bracket and out through the slots. Reuse the factory nuts to attach the Mounting Bracket to the frame, **(Figure 13)**. Do not tighten hardware.
 - b. Repeat the previous Steps to install the Passenger/Right Mounting Bracket and factory bolt plate.
- 10. With assistance, hold the Bumper assembly up to the end of the frame. Temporarily support the weight of the Bumper. WARNING: To avoid possible injury or damage to the vehicle, do not proceed until the bumper is fully and safely supported.**
- 11. Attach the Bumper to the Mounting Brackets with (4) 10mm Flat Washers and (4) 10mm Nylon Lock Nuts, (Figure 14). Do not tighten hardware.**
- 12. Level and adjust the bumper and fully tighten all hardware.**
- 13. Plug bumper and trailer wiring harness into main harness.**
- 14. Do periodic inspections to the installation to make sure that all hardware is secure and tight.**

To protect your investment: Do not use any type of polish or wax that may contain abrasives that could damage the finish. Mild soap may be used to clean the Bumper assembly.

**EXTREME HD REAR BUMPER – SKU # T556619
2021 FORD F150**

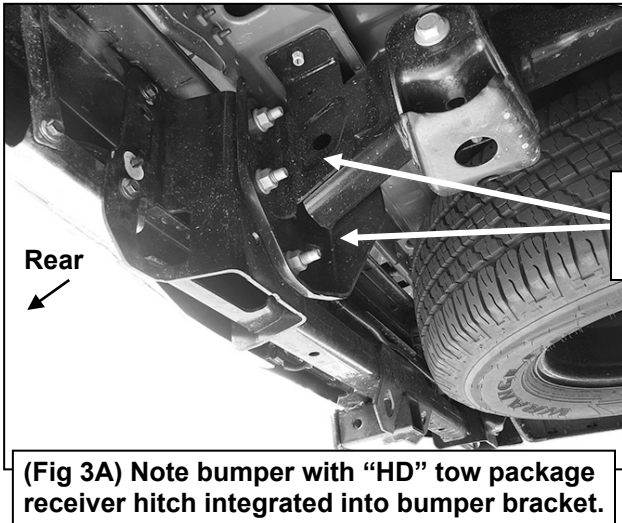
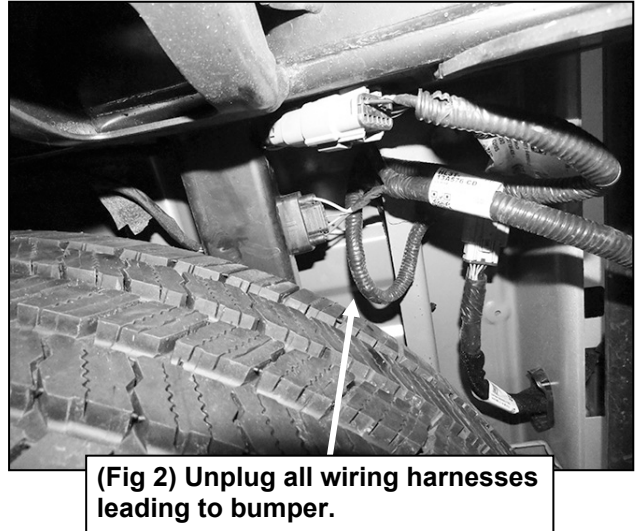

WARNING! Do not crawl under bumper unless the bumper is properly supported on blocks or stands or the bumper may fall.

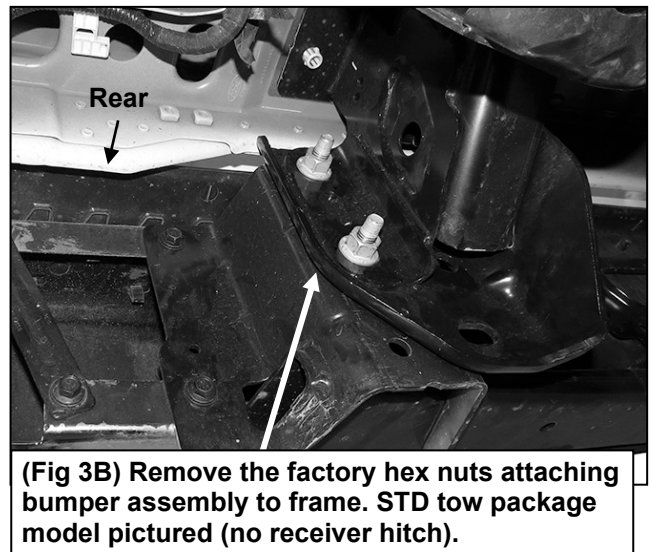

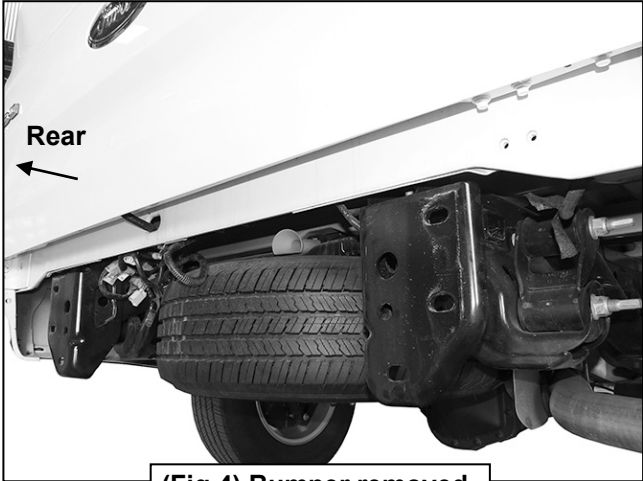

(Fig 4) Bumper removed.



(Fig 5) Disassemble bumper to remove license plate lights, trailer plug, sensors and wiring harness from bumper as equipped.

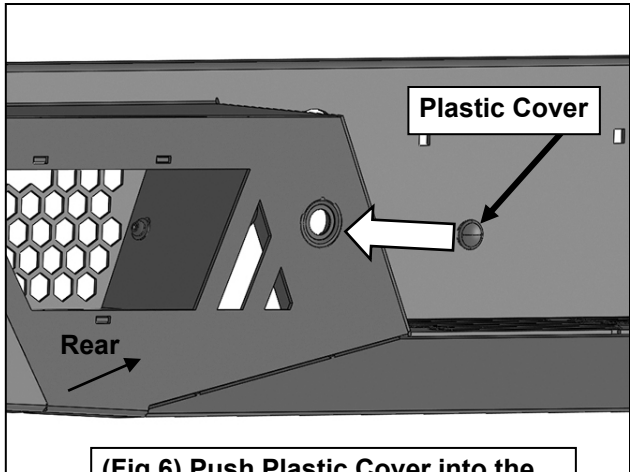

(Fig 6) Push Plastic Cover into the front of the sensor mounting sleeve.

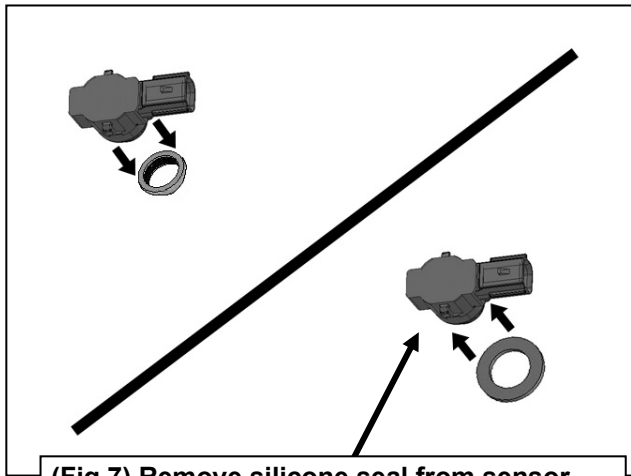

(Fig 7) Remove silicone seal from sensor. Slide large Seal over end of sensor (arrow).

Driver/left Side Installation Pictured

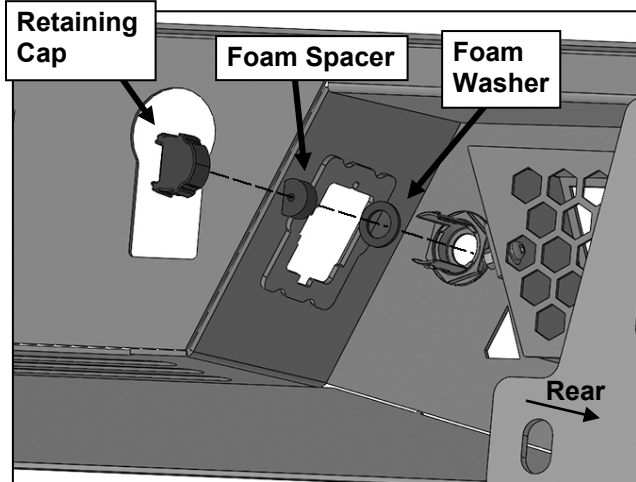

(Fig 8) Sensor assembly pictured from back of bumper.

WARNING! Do not remove bumper bolts unless the bumper is properly supported on blocks or stands or the bumper may fall.

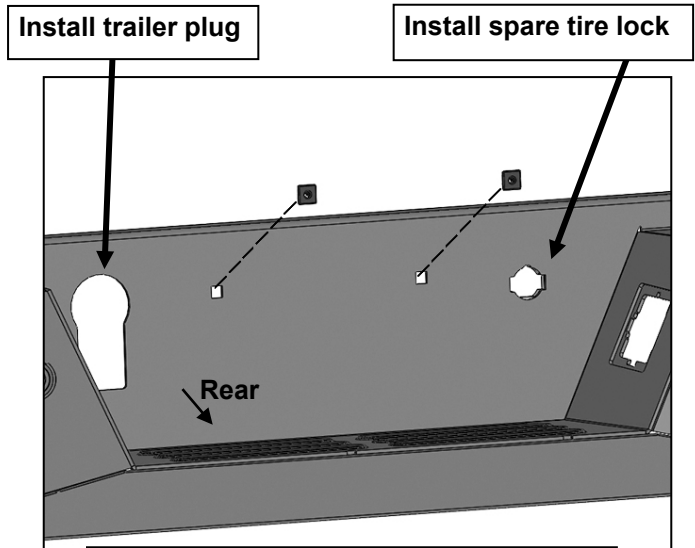

(Fig 9) Push plastic plugs into holes for license plate. Install license plate lights.

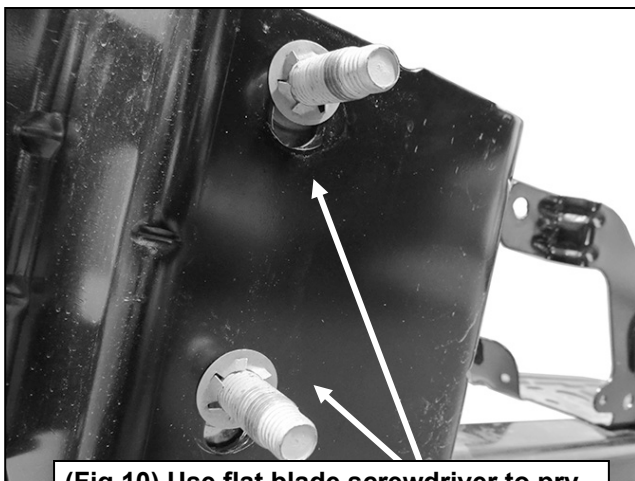

(Fig 10) Use flat blade screwdriver to pry off lock washers from factory bolt plates.

Driver/left Side Installation Pictured

WARNING! Do not crawl under bumper unless the bumper is properly supported on blocks or stands or the bumper may fall.

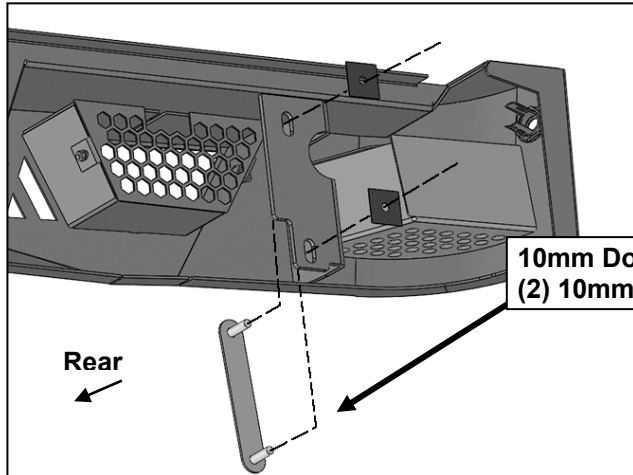

10mm Double Bolt Plate
(2) 10mm Plastic Retainers

Rear

(Fig 11) Insert 10mm Double Bolt Plate into back of Bumper. Use 10mm Plastic Retainers to hold Bolt Plate in position (retainer use optional).

Factory double bolt plate.
Reuse factory hex nuts to attach Bumper.

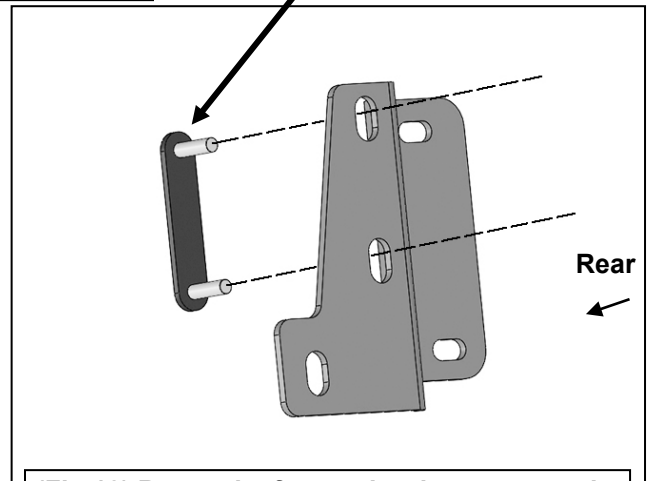

Rear

(Fig 12) Reuse the factory hardware to attach the Driver/Left Mounting Bracket to the frame, (Factory double bolt plate shown).

Factory triple bolt plate.
Reuse factory hex nuts to attach Bumper.

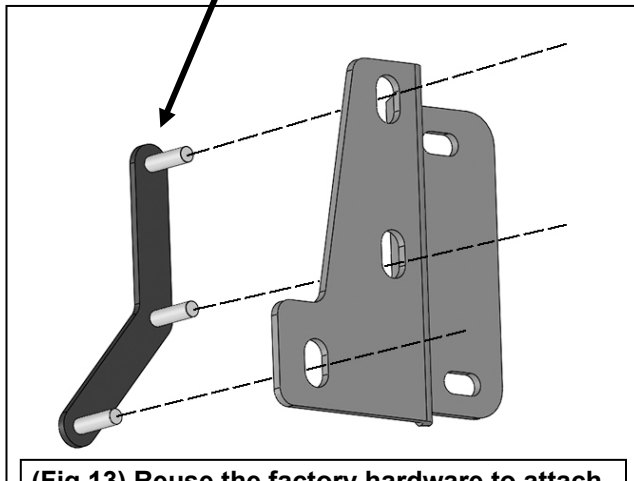

(Fig 13) Reuse the factory hardware to attach the Driver/Left Mounting Bracket to the frame, (Factory triple bolt plate shown).

(2) 10mm Flat Washers
(2) 10mm Nylon Lock Nuts

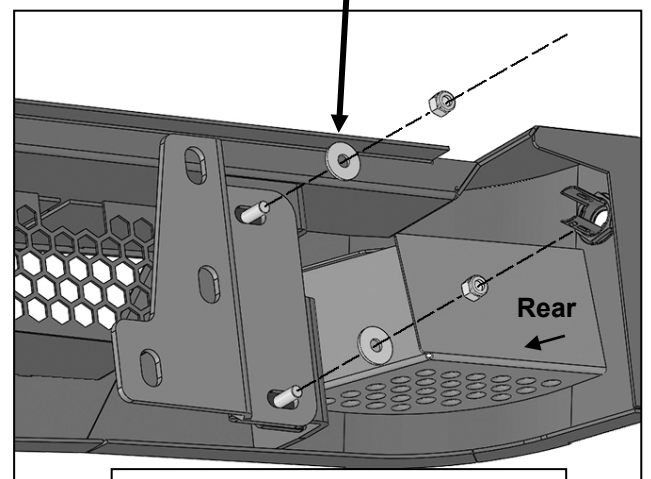

Rear

(Fig 14) Attach the Rear Bumper to the Mounting Brackets.

WARNING! Do not crawl under bumper unless the bumper is properly supported on blocks or stands or the bumper may fall.