

INSTALLATION INSTRUCTIONS

CS-1 HD WINCH FRONT BUMPER

21-22 FORD F150

T565064

**CS-1 HD WINCH FRONT BUMPER
21-22 FORD F150**

PARTS LIST:

1	CS1 HD Front Bumper Assembly	4	10mm x 20mm x 2mm Flat Washer
1	Winch Tray/Bracket Assembly	2	10mm Nylon Lock Nuts
2	14mm x 28mm x 30mm Tube Spacers	2	8-1.25mm x 30mm Hex Bolts
1	Winch Control Relocation Bracket	2	8-1.25mm x 25mm Hex Bolts
1	Driver/left Support Bracket	2	8-1.25mm x 16mm Hex Bolts (LED light bar)
1	Passenger/right Support Bracket	6	8mm x 24mm Flat Washers (stainless)
1	Lower Air Deflector	4	8mm x 24mm Flat Washers
1	Driver/left Bumper LED Bracket (no hoop)	4	8mm Lock Washers
1	Passenger/right Bumper LED Bracket (no hoop)	2	8mm Hex Nuts
1	Driver/left "L" Bracket (hoop LED light)	2	8mm Nylon Lock Nuts
1	Passenger/right "L" Bracket (hoop LED light)	3	6mm x 20mm Button Head Combo Bolts
1	License Plate Bracket	4	6mm x 20mm Button Head Bolts
2	Plastic Plugs for license plate mount	2	6mm x 25mm Hex Bolts
2	Sensor Retaining Caps	12	6mm x 18mm x 1.6 Flat Washers
2	20mm x 10mm Foam Spacers	6	6mm Nylon Lock Nuts
2	15.5mm x 25mm x 2mm Foam Seals	4	4mm Self Tapping Screws
2	Plastic Sensor Hole Plugs	1	6mm Wrench
2	Wire Harness Extensions	1	5mm Wrench
1	Sensor Cover Kit	1	4mm Wrench
2	12-1.75mm Double Nut Plates	10	Nylon Wire Ties
6	12-1.75mm x 65mm Bolt Plates	1	57mm Hole Plug
4	12-1.75mm x 45mm Hex Bolts	4	Hole Plugs (bumper top)
10	12-1.75mm x 40mm Hex Bolts	1	1760mm Bumper Edge Trim
24	12mm x 32mm x 3mm Flat Washers	1	200mm Edge Trim
20	12mm Lock Washers	1	Driver/left Factory bumper cutting template
10	12mm Hex Nuts	1	Passenger/right Factory bumper cutting template
6	12mm Plastic Retainers	1	Cutting Template for Static Air Dam/Lower bumper valence
2	10-1.5mm x 30mm Button Head Bolts		

**CS-1 HD WINCH FRONT BUMPER
21-22 FORD F150**

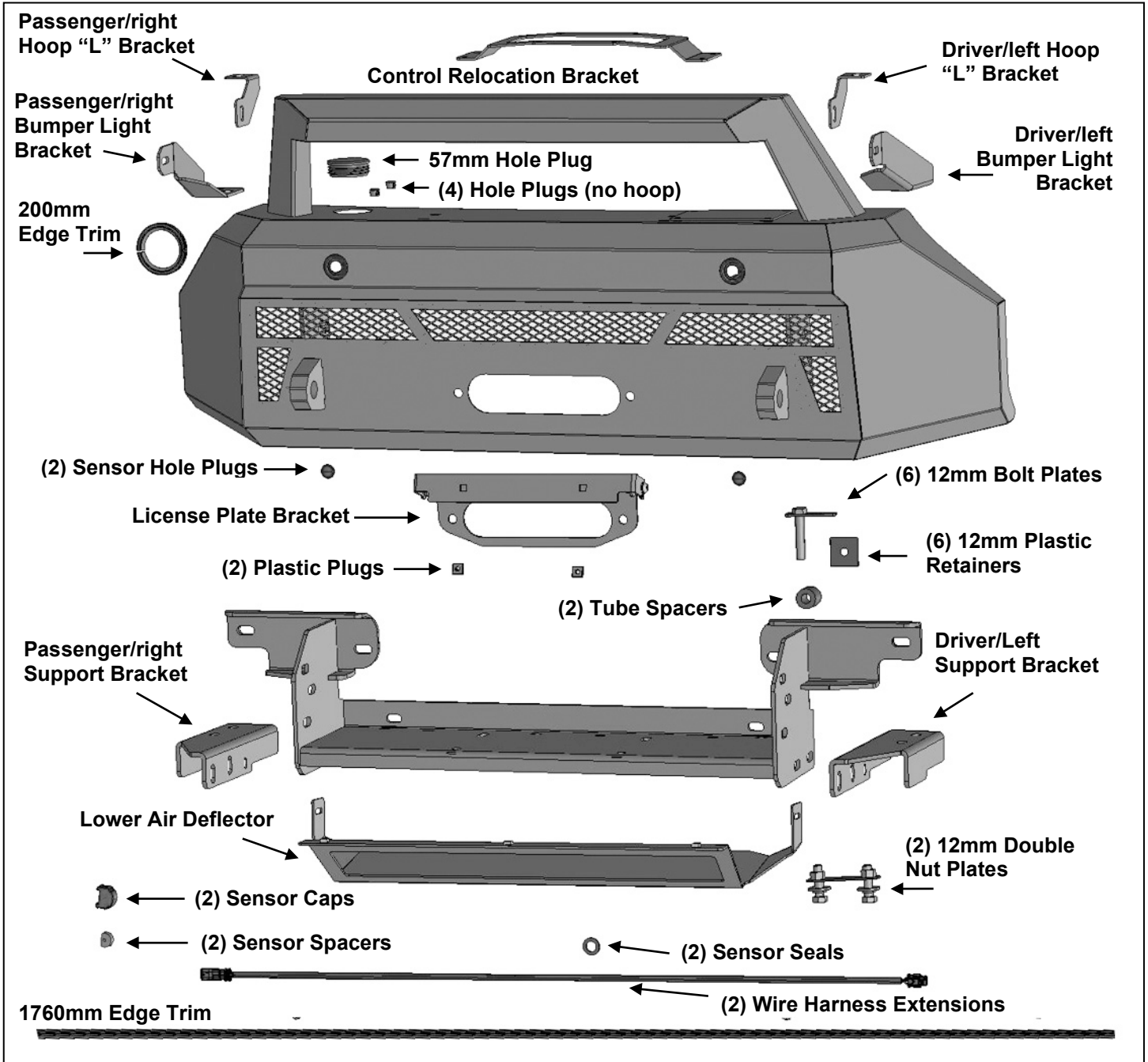

PROCEDURE:

REMOVE CONTENTS FROM BOX. VERIFY ALL PARTS ARE PRESENT. READ INSTRUCTIONS CAREFULLY BEFORE STARTING INSTALLATION. BUMPER IS HEAVY, ASSISTANCE IS HIGHLY RECOMMENDED TO AVOID POSSIBLE INJURY OR DAMAGE TO THE VEHICLE. BUMPER IS NOT COMPATIBLE WITH ACC (ADAPTIVE CRUISE CONTROL). FUNCTION MUST BE DISABLED OR SENSOR RELOCATED.

1. Remove the license plate and bracket.
2. From behind the front bumper, unplug and remove the active air dam from the bottom of the frame, **(Figures 1 & 2)**.
3. With the air dam out of the way, locate and unplug the main harness plug on the top of the passenger/right frame rail behind the bumper bracket, **(Figure 3)**. Unplug any remaining harnesses leading to the bumper. On hybrid models, temporarily unplug and remove the speaker assembly for the

**CS-1 HD WINCH FRONT BUMPER
21-22 FORD F150**

pedestrian audible alert system from the driver/left frame channel, **(Figure 4)**. Note speaker is located on the inner side of the frame, behind the driver/left bumper bracket. From below, remove the hex bolt and drop the speaker down, unplug and remove, **(Figure 5)**.

4. Place blocks or jack stands under the front bumper to support it during mounting hardware removal. Once the bumper has been safely supported, remove the large hex nuts from the back of each bumper bracket attaching the bumper to the bumper brackets, **(Figure 6)**. **WARNING!** Assistance is required to hold the bumper in place during hardware removal to prevent the bumper from falling. Carefully slide the bumper off over the tow hooks if equipped.
5. On models with bolt on frame extensions, remove the extensions from outside of frame, **(Figure 6)**. **NOTE:** It may be necessary to cut the factory bolts to remove frame extensions, (removal is optional).
6. Remove the plastic shroud from in front of the active shutter assembly. Models with tow hooks, remove both tow hooks, **(Figure 6)**. **NOTE:** Tow hooks cannot be reinstalled.
7. Move the factory bumper to a stable work surface. Remove the (2) center parking sensors if equipped. Release the center section of the wiring harness from the clips.
8. Remove the fog light assemblies if equipped, **(Figure 7)**.
9. Select the driver/left Upper Cutting Template. Use scissors to cut out the Template. Place the Template over the driver/left side of the factory bumper, **(Figure 8)**. Use a marker or removable tape to draw the outline of the Template onto the front of the bumper. Repeat this Step to mark the passenger/right side of the bumper. **NOTE:** Tape Upper Templates together to mark the full width of the bumper, **(Figure 9)**.
10. Use a hacksaw blade or knife to cut the top of the plastic bumper cover along the lines from the Templates. Carefully move all wiring harnesses before cutting.
11. Next, from the front, locate the top outer corner of the opening for the driver/left tow hook, **(Figure 10)**. Cut the bottom of the bumper cover above the tow hook opening. Repeat this Step to cut the passenger/right side of the lower bumper cover. Remove the hardware attaching the top of the air dam to the bottom of the bumper cover to remove the cut section, **(Figure 11)**.
12. Remove the driver/left bumper bracket from the back of the bumper, **(Figure 11)**. Use a flat blade screwdriver to pry off the locking washers securing the triple bolt plate to the bumper bracket. Repeat this Step to remove the passenger/right bumper bracket.
13. Remove the lower air dam. Locate and mark the center of the air dam, **(Figure 12)**.
14. Select the Air Dam Cut Template, **(Figure 13)**. Trace the outline of the Template onto the air dam, **(Figure 14)**. Cut out the rectangular section from the air dam, **(Figure 15)**.
15. Select the Winch Tray/Bracket Assembly. Attach the inner tab on the driver/left Bumper Bracket to the single slot in back of the Winch Tray with the included (1) 8mm x 30mm Hex Bolt, (2) 8mm Flat Washers and (1) 8mm Nylon Lock Nut, **(Figures 16 & 17)**. Insert (1) 12mm Bolt Plate through the top outer mounting hole in the Winch Tray and factory bumper bracket. Thread (1) 12mm Plastic Retainer onto the threaded end of the Bolt Plate to help hold it in place in the Bracket Assembly. Repeat to insert (1) 12mm Bolt Plate in to outer/lower mounting hole in the factory bumper bracket.
16. Select (1) Tube Spacer. Slide the Tube Space between the inner mounting hole in the factory bumper bracket and the Winch Tray Assembly, **(Figures 16 & 18)**. Insert (1) 12mm Bolt Plate through the factory bumper bracket, the Tube Spacer and Bracket Assembly. Thread (1) 12mm Plastic Retainer onto the Bolt Plate to hold in place.
17. Repeat **Steps 15 & 16** to attach the passenger/right side factory bumper bracket to the Winch Tray Bracket Assembly.
18. Reuse the factory hardware to attach the Winch Tray and factory bumper brackets to the back of the factory bumper, **(Figure 19)**.
19. Reinstall the fog light assemblies if equipped. Reattach the factory wiring harness.
20. With assistance, hold the factory bumper with Winch Tray Assembly up the end of the frame. Attach the bumper assembly to the frame with the included (6) 12mm Flat Washers, (6) 12mm Lock Washers and (6) 12mm Hex Nuts, **(Figures 20 & 21)**. Align the bumper assembly to the vehicle. Do not fully tighten hardware.
21. Select the driver/left Support Bracket. Attach the Support Bracket to the bottom of the frame with the included (2) 12mm x 45mm Hex Bolts, (2) 12mm Lock Washers and (2) 12mm Flat Washers, **(Figures 22 & 23)**. **NOTE: Models without factory tow hooks**, first insert (1) 12mm Double Nut Plate into the

CS-1 HD WINCH FRONT BUMPER
21-22 FORD F150

open end of the frame, **(Figure 22)**. Line up Nut Plate with holes in the bottom of the frame then attach Support Bracket to frame and Nut Plate.

22. Attach the side of the driver/left Support Bracket to the outside of the Winch Tray with the included (2) 12mm x 40mm Hex Bolts, (4) 12mm Flat Washers, (2) 12mm Lock Washers and (2) 12mm Hex Nuts, **(Figures 24 & 25)**.
23. Repeat **Steps 21 & 22** to attach the passenger/right Support Bracket.
24. Carefully unwrap the CS1 HD Bumper. Apply the included Edge Trim to the edge of the Bumper, **(Figure 26)**. Hold the CS1 Bumper up to the outside of the mounting tabs on the Winch Tray to check alignment of the Winch Tray Bracket Assembly. Adjust Winch Tray side to side if necessary and tighten all mounting hardware. Move CS1 Bumper to a stable work surface.
25. Reuse the factory hardware to attach the air dam to the bottom of the Winch Tray, **(Figure 25)**.
26. Determine if winch will be installed.

Winch will not be installed: Insert large Plastic Plug into hole in top of Bumper, **(Figure 27)**.

Winch will be installed, Cable Guide and Winch installation, (guide and winch not included).

- a. Place the winch in position on the winch tray to check for clearance. Adjust or modify vehicle for clearance as necessary.
 - b. Push the included 200mm Edge Trim onto the access hole in the top of the CS1 Bumper, **(Figure 28)**. Remove Access Cover.
 - c. Attach the cable guide, (not included), to the front of the CS1 HD Bumper with the included (2) 10mm x 30mm Button Head Bolts, (4) 10mm Flat Washers and (2) 10mm Nylon Lock Nuts, **(Figure 29)**.
 - d. On models with front license plate, insert the included License Plate Bracket between the cable guide and the front of the CS1 Bumper, **(Figure 29)**.
 - e. Follow the instructions packaged with the winch to remove the controller from the top of the winch if necessary. Attach the included Controller Relocation Bracket to the bottom of the controller, **(Figures 30 & 31)**. Attach the controller and Relocation Bracket to the top of the CS1 Bumper with the included (4) 6mm x 20mm Button Head Bolts, (8) 6mm Flat Washers and (4) 6mm Nylon Lock Nuts.
 - f. Follow instructions packaged with winch to install winch and connect electrical system after installing CS1 Bumper.
27. Determine if vehicle is equipped with parking sensors.

Models without bumper sensors:

- a. From the front of the CS1 Bumper, push the included Plastic Plugs into sensor holes, **(Figure 32)**.

Models with bumper mounted parking sensors:

- a. Select (1) sensor removed in **Step 7**. Remove the silicone seal from the end of the sensor, **(Figure 33)**.
- b. Slide the included larger Foam Seal over front of sensor, **(Figure 33)**.
- c. Insert sensor with Seal into sensor mount on CS1 Bumper, **(Figure 34)**.
- d. Place Thick Foam Spacer over end of sensor. Push Sensor Retaining Cap onto sensor mount and snap into place, **(Figure 34)**.
- e. Repeat previous **Steps** to install remaining sensor.
- f. Plug the included Wiring Harness Extensions into the bumper wiring harness to extend the reach to the sensors to the CS1 Bumper if needed.

28. Determine if Bull Nose Hoop (preinstalled on Bumper) will be used. **NOTE:** Bull Nose Hoop may interfere with grille mounted camera if equipped and is not recommended with this option.

Top LED light installation with Bull Nose Hoop (light not included).

- a. Select the L/R "L" Brackets, **(Figure 35)**. Attach the Brackets to the bottom of the Bull Nose Hoop with the included (2) 8mm x 25mm Hex Bolts, (4) 8mm Flat Washers, (2) 8mm Lock Washers and (2) 8mm Hex Nuts. Leave loose at this time.
- b. Attach the LED light assembly to the "L" Brackets with the included (2) 8mm x 16mm Hex Bolts, (2) 8mm Lock Washers and (2) 8mm Flat Washers, **(Figure 35)**. Do not fully tighten hardware at this time. **IMPORTANT:** "L" Brackets are designed for 8mm light mounting hardware only.

**CS-1 HD WINCH FRONT BUMPER
21-22 FORD F150**

Modify "L" Brackets if necessary or use brackets supplied by the light manufacturer to install hardware larger than 8mm.

- c. Follow light manufacturer's instructions to properly wire the light.

LED Light installation on top of CS1 Bumper, Bull Nose Hoop Removed.

- a. Remove Bull Nose Hoop. Reuse the mounting hardware to attach the driver/left Light Bracket to the top of the CS1 Bumper, **(Figure 36)**. Repeat to install the passenger/right Light Bracket.
 - b. Attach the LED light assembly to the Brackets with the included (2) 8mm x 16mm Hex Bolts, (2) 8mm Lock Washers and (2) 8mm Flat Washers, **(Figure 13)**. Do not fully tighten hardware at this time. **IMPORTANT:** Brackets are designed for 8mm light mounting hardware only. Modify Brackets if necessary to install hardware larger than 8mm.
 - c. Follow light manufacturer's instructions to properly wire the light to the vehicle.
 - d. **If light will not be installed**, use the included (4) Plugs to cover the mounting holes in the top of the Bumper, **(Figure 36)**.
- 29.** With assistance, position the Bumper Assembly up to the front of the vehicle. On models with parking sensors, plug the wiring harnesses into the parking sensors. Hold the Bumper up to the inside of the Mounting Tabs on the Winch Tray. Temporarily support the weight of the Bumper. **WARNING:** To avoid possible injury or damage to the vehicle, do not proceed until the bumper is fully and safely supported.
- 30.** Attach the driver/left mounting plate on the back of the Bumper to the inside of the Mounting Tab on the Winch Tray with the included (3) 12mm x 40mm Hex Bolts, (3) 12mm Lock Washers and (3) 12mm Flat Washers, **(Figures 37 & 39)**. Repeat this Step to attach the passenger/right side of the Bumper to the Bracket. Do not fully tighten hardware at this time.
- 31.** Level and adjust the bumper and fully tighten all hardware.
- 32.** Select the Lower Air Deflector. Attach the front of the Air Deflector to the inside of the Bumper with the included (3) 6mm x 20mm Button Head Combo Bolts, **(Figure 38)**. Attach the tabs on the side of the Air Deflector to the inside of the Support Brackets with (2) 6mm x 25mm Hex Bolts, (4) 6mm Flat Washers and (2) 6mm Nylon Lock Nuts, **(Figures 38 & 39)**. Fully Tighten Hardware.
- 33.** Reinstall active air dam if desired. On hybrid models, reinstall the speaker assembly for the pedestrian audible alert system removed in **Step 3**.
- 34.** Do periodic inspections to the installation to make sure that all hardware is secure and tight.

To protect your investment, Do not use any type of polish or wax that may contain abrasives that could damage the finish. Mild soap may be used to clean the Bumper assembly.

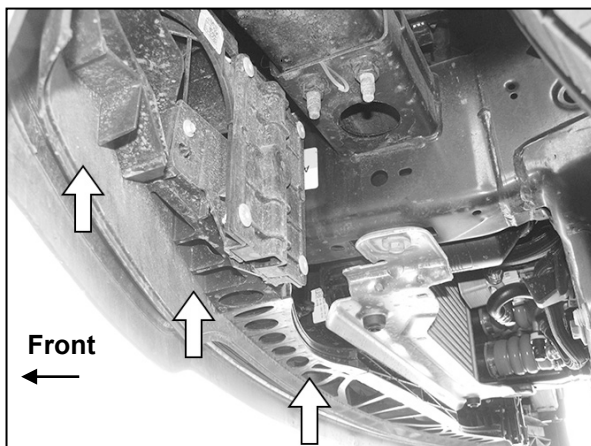

(Fig 1) Active air dam behind bumper

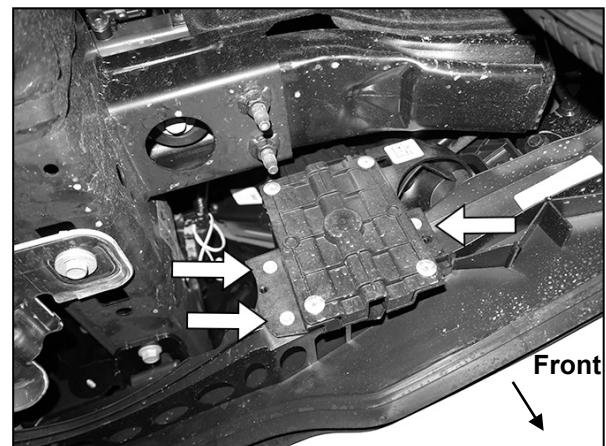

(Fig 2) Remove bolts (arrows) to remove active air dam from motors (passenger/right side pictured)

**CS-1 HD WINCH FRONT BUMPER
21-22 FORD F150**

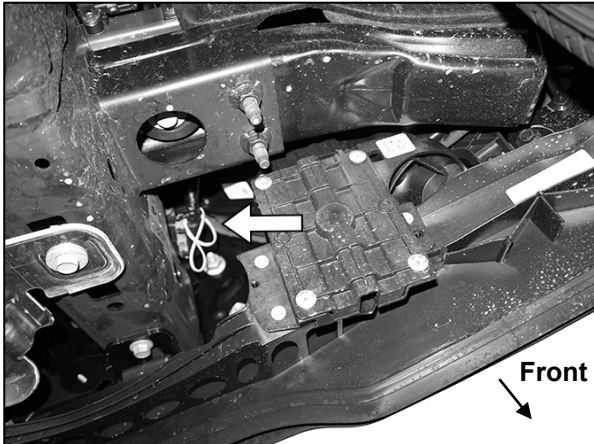

(Fig 3) Locate and unplug main harness plug on passenger/right side of bumper (arrow)

WARNING! Do not remove bumper bolts unless it is properly supported on blocks or stands or the bumper may fall.

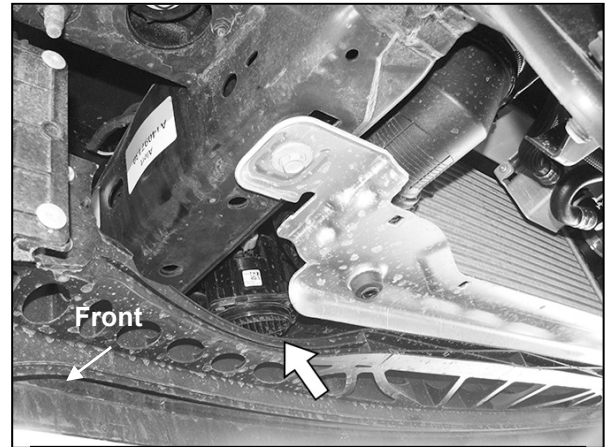

(Fig 4) Hybrid Models Only, locate alert speaker behind driver/left side of bumper



(Fig 5) Remove bolt (arrow) to temporarily remove audible alert speaker located behind driver/left side of bumper (hybrid models only-pictured from below)

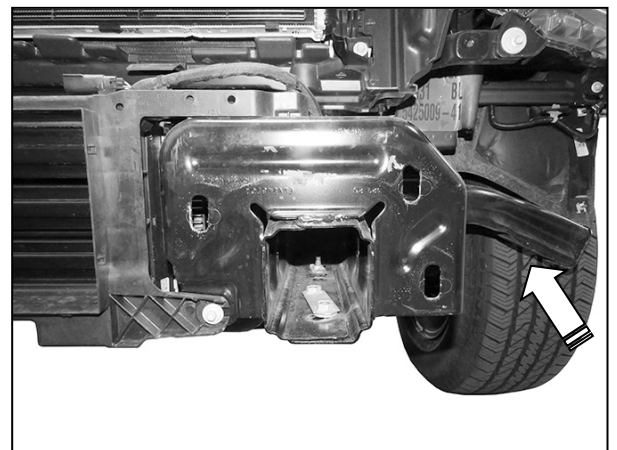

(Fig 6) Remove bumper. Also remove the factory frame extension (arrow-optional)

Driver/left Side Installation Pictured

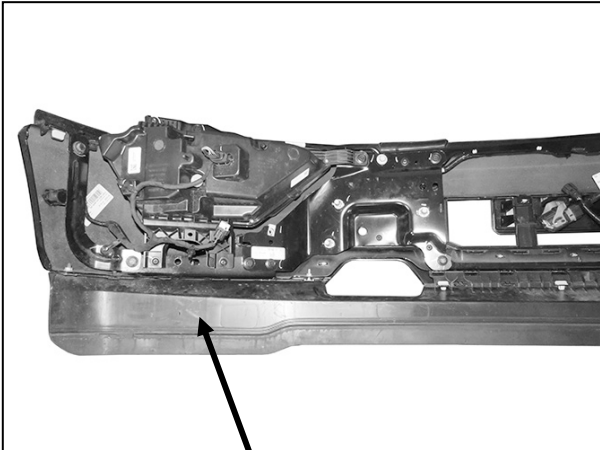

(Fig 7) Remove fog light assembly if equipped



(Fig 8) Place bumper Cut Template onto front bumper. Trace outline of cut template onto bumper cover. Driver/left side pictured

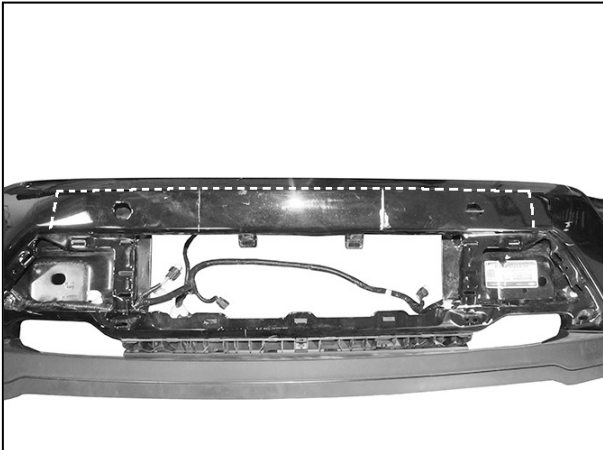

(Fig 9) Place bumper Cut Templates onto front bumper. Trace outline of cut templates onto bumper cover. Cut along traced line



(Fig 10) Cut along dashed line (arrow). Remove air dam hardware and cut lower section

Driver/left Side Installation Pictured

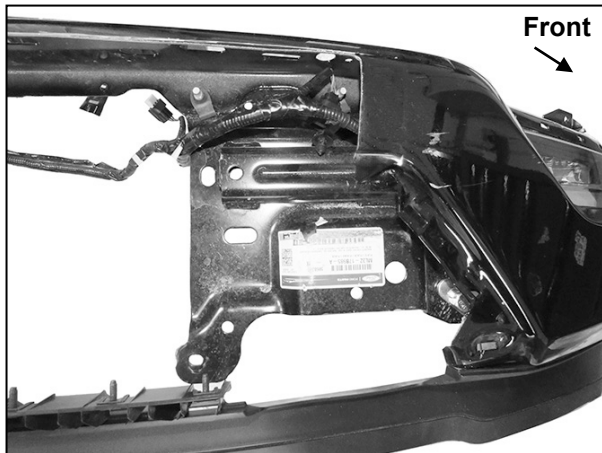

(Fig 11) Remove air dam and both steel bumper brackets from bumper

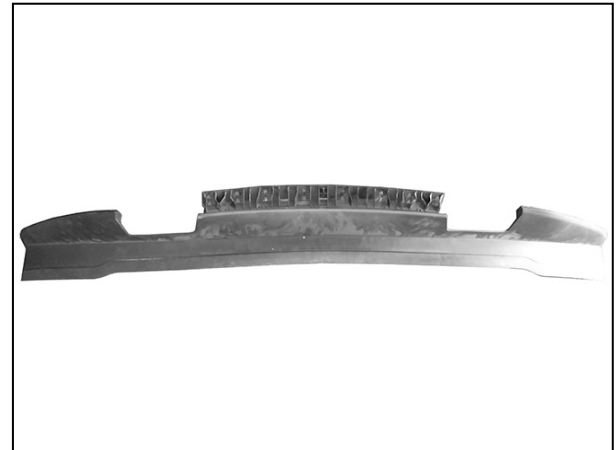

(Fig 12) Locate center of air dam

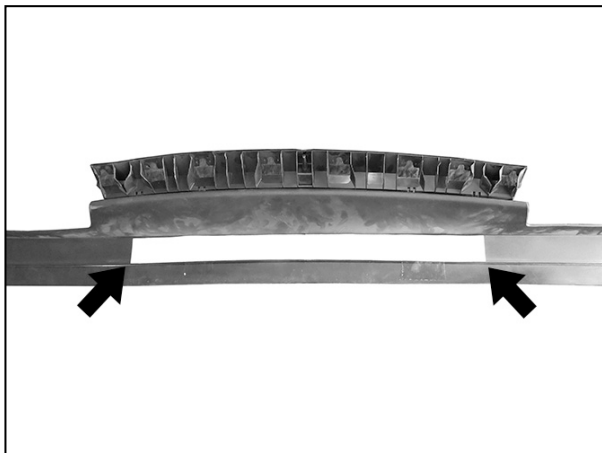

(Fig 13) Place Cut Template onto air dam.

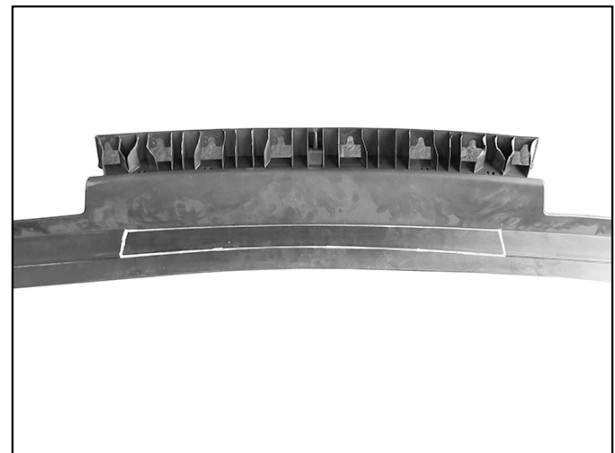

(Fig 14) Trace outside of cut template onto air dam

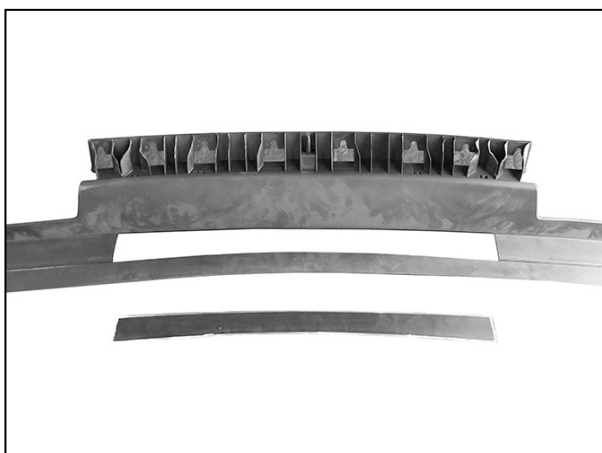

(Fig 15) Cut opening into air dam

Driver/left Side Installation Pictured

(3) 12mm Bolt Plates
(3) 12mm Plastic Retainers

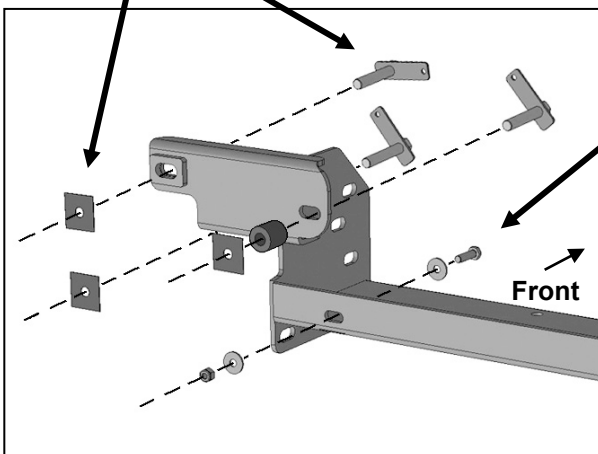

8mm x 30mm Hex Bolt
(2) 8mm Flat Washers
8mm Nylon Lock Nut

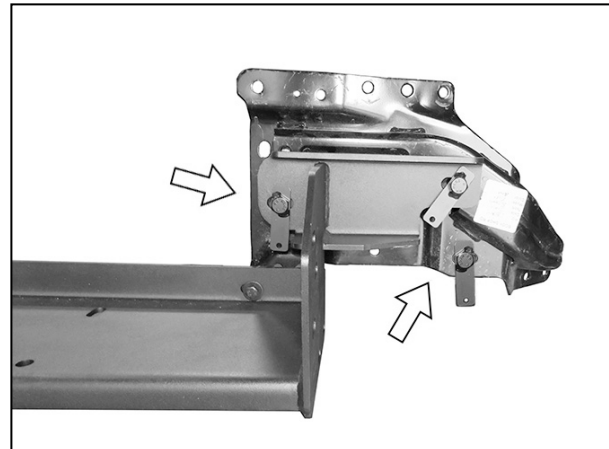

(Fig 16) Insert (2) Bolt Plates through top holes in Bracket Assembly. Slide Tube Spacer onto inner Bolt Plate. Attach steel bumper bracket to slot in Winch Tray. Thread Plastic Retainers onto Bolt Plates to hold steel bumper bracket in place.

(Fig 17) Insert (1) Bolt Plate through lower outer hole in steel bumper bracket. Thread Plastic Retainer onto Bolt Plate to hold in place. Driver/left side pictured

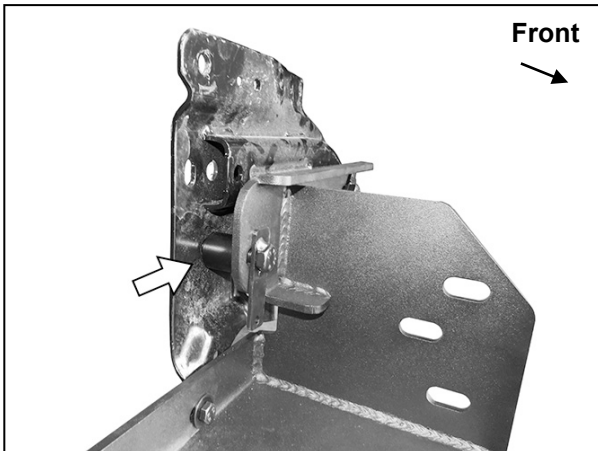

(Fig 18) Slide Tube Spacer between steel bumper bracket and Winch Tray Bracket Assembly (arrow). Insert Bolt Plate through Winch Tray, Spacer and steel bumper bracket. Thread Plastic Retainer onto Bolt Plate to hold steel bumper bracket in place.

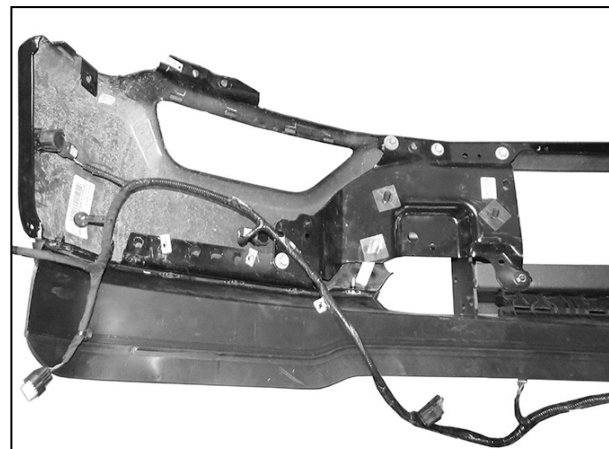

(Fig 19) Attach steel bumper brackets and Winch Tray Bracket Assembly to factory bumper. NOTE: Plastic Retainers used to hold Bolt Plates in place.

Driver/left Side Installation Pictured

- (3) 12mm Flat Washers
- (3) 12mm Lock Washers
- (3) 12mm Hex Nuts

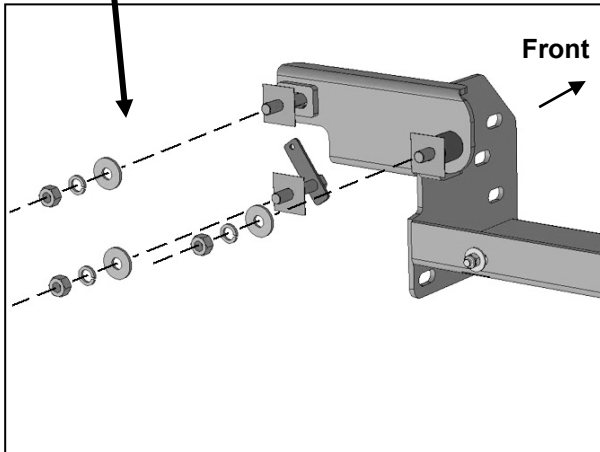

(Fig 20) Attach factory bumper with inner Winch Tray Bracket Assembly to end of frame

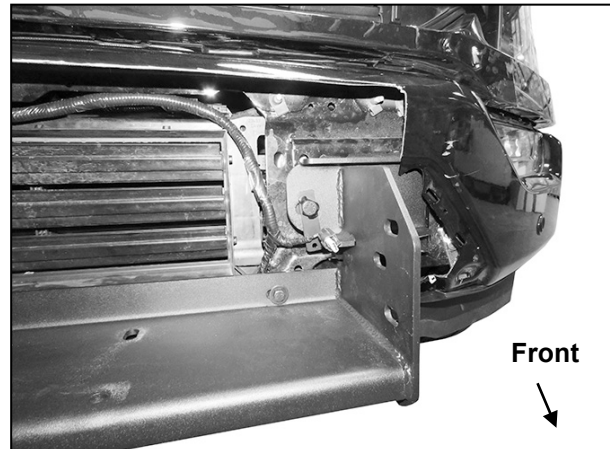

(Fig 21) Attach factory bumper with inner Winch Tray Bracket Assembly to end of frame



(Fig 22) Models without tow hooks, insert Double Nut Plate into open end of frame (arrow). Reuse the factory hardware to attach the air dam to the bottom of the Winch Tray

- (2) 12mm x 45mm Hex Bolts
- (2) 12mm Lock Washers
- (2) 12mm Flat Washers

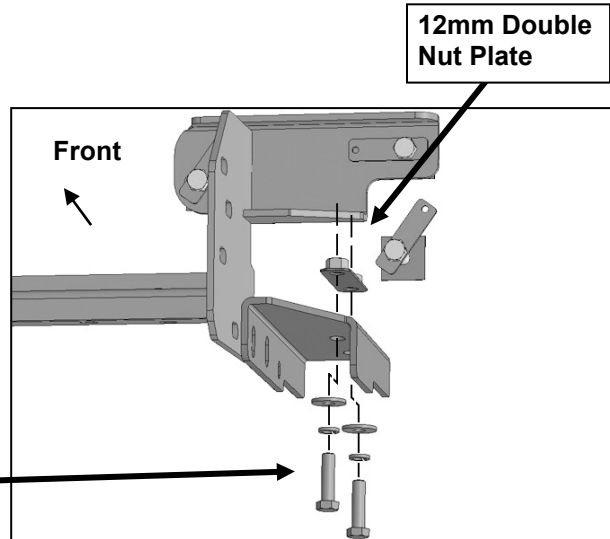

(Fig 23) Attach driver/left Support Bracket to bottom of frame and inner nut plate

Driver/left Side Installation Pictured

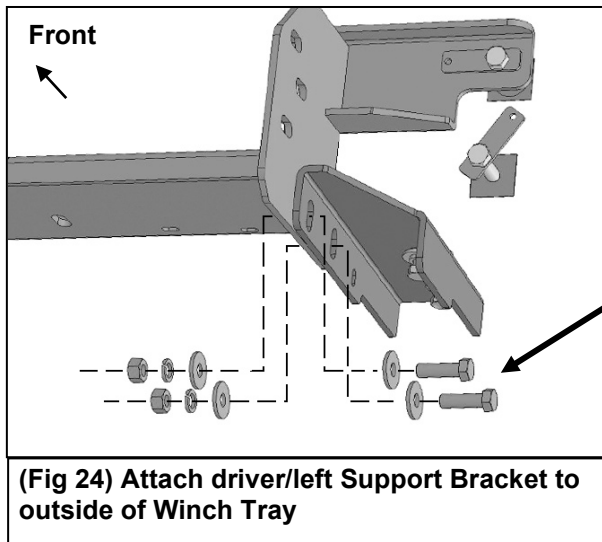

- (2) 12mm x 40mm Hex Bolts
- (4) 12mm Flat Washers
- (2) 12mm Lock Washers
- (2) 12mm Hex Nuts

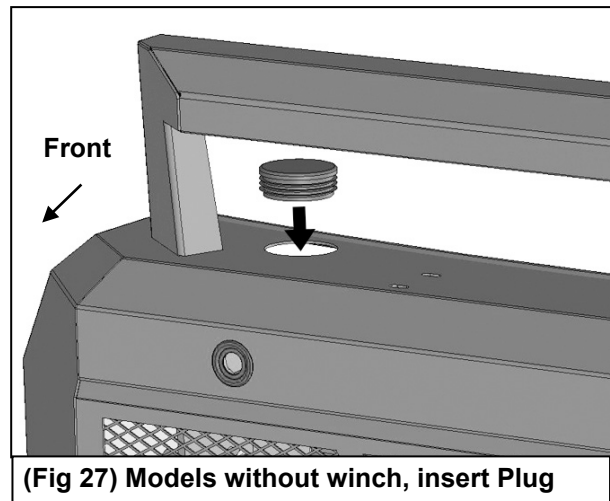
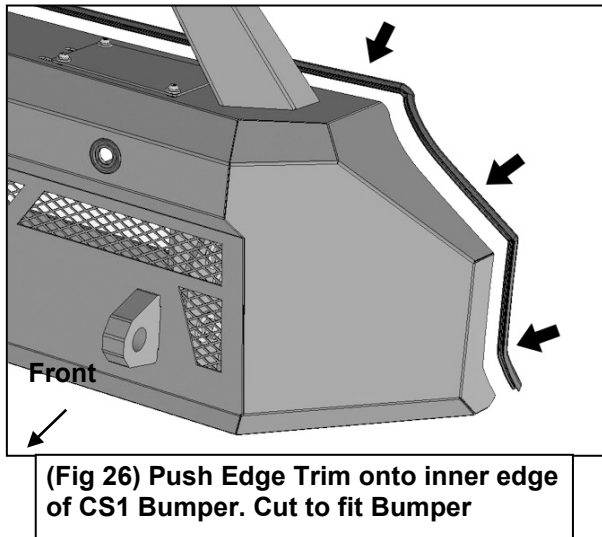
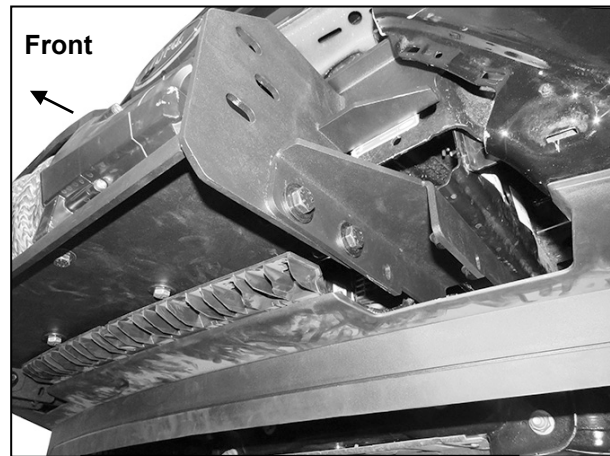

Driver/left Side Installation Pictured

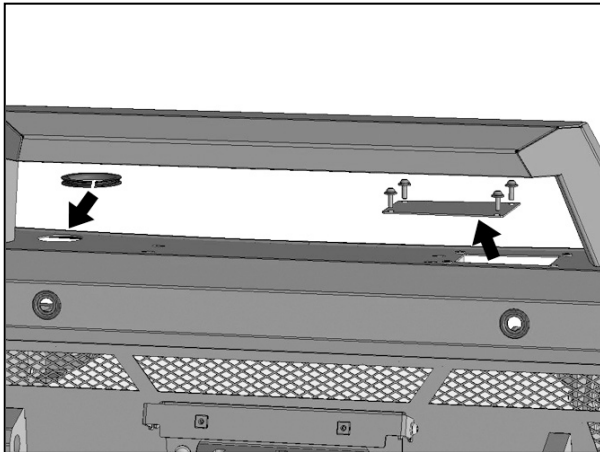

(Fig 28) Models with winch, push 200mm long Edge Trim around hole in Bumper. Remove Cover to access winch release lever

- (4) 6mm x 20mm Button Head Bolts
- (8) 6mm Flat Washers
- (4) 6mm Nylon Lock Nuts

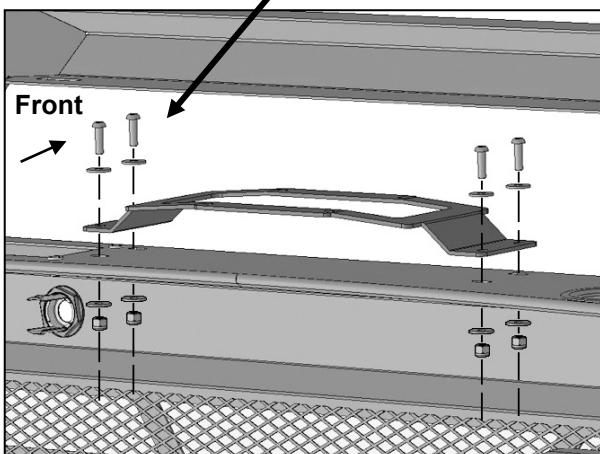

(Fig 30) Attach Relocation Bracket to winch control unit. Attach assembly to top of Bumper

- (2) 10mm x 30mm Button Head Bolts
- (4) 10mm Flat Washers
- (2) 10mm Nylon Lock Nuts

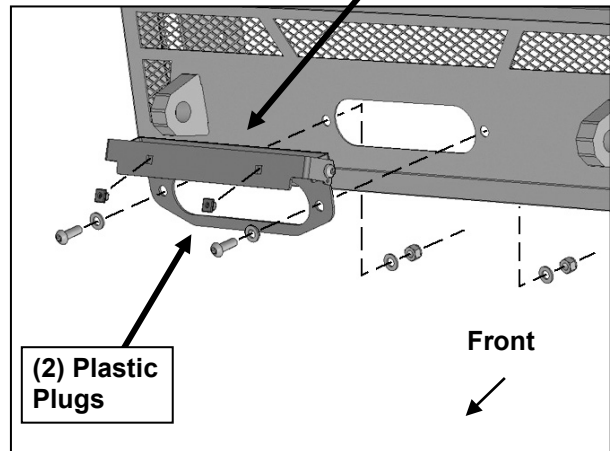

- (2) Plastic Plugs

(Fig 29) Attach cable guide to front of CS1 Bumper. Insert License Plate Bracket between cable guide and Bumper if required

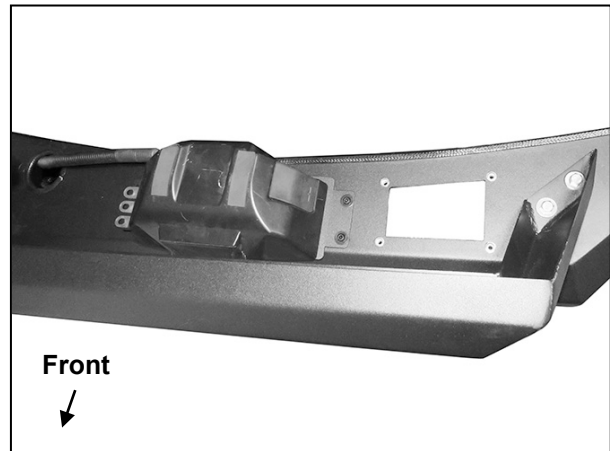

(Fig 31) Attach Relocation Bracket to winch control unit. Attach assembly to top of Bumper

Driver/left Side Installation Pictured

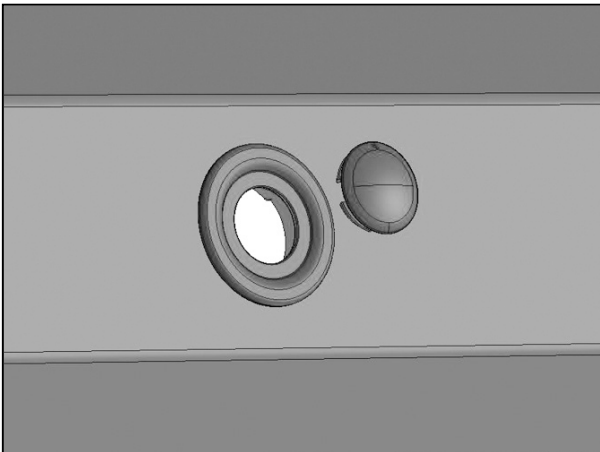

(Fig 32) Models without parking sensors, push the included Plugs into sensor mounts

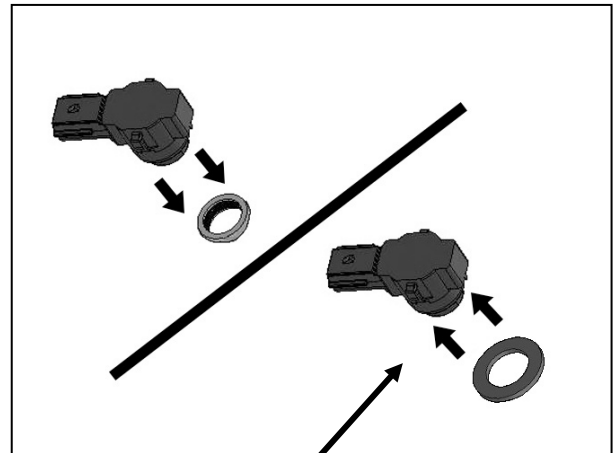

(Fig 33) Remove silicone seal from sensor. Slide large Seal over end of sensor (arrow)

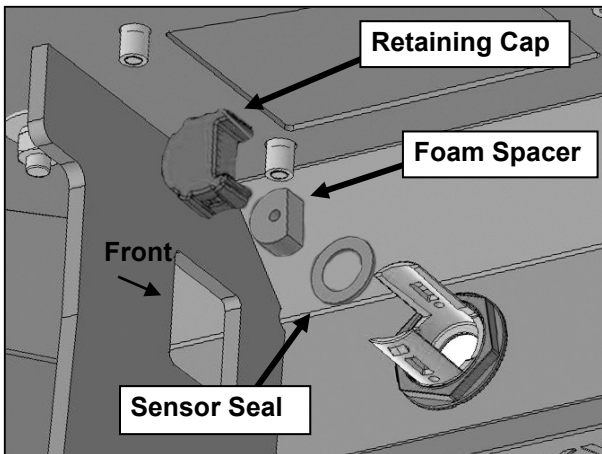

(Fig 34) Insert sensor assembly into the sensor mount on back of Bumper

- 8mm x 16mm Hex Bolt
- 8mm Lock Washer
- 8mm Flat Washer
- 8mm x 25mm Hex Bolt
- (2) 8mm Flat Washers
- 8mm Lock Washer
- 8mm Hex Nut

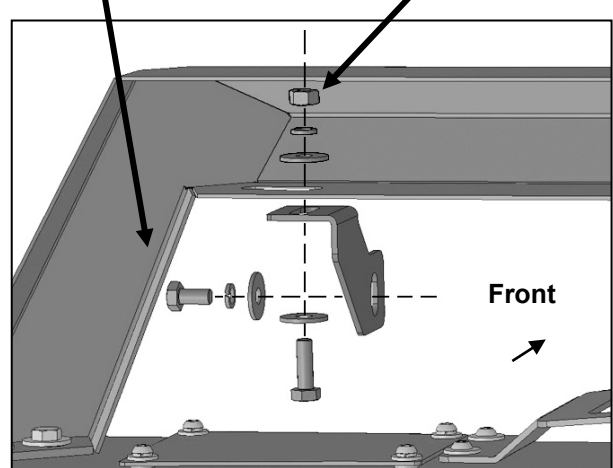

(Fig 35) Attach LED "L" Brackets to bottom of hoop

Driver/left Side Installation Pictured

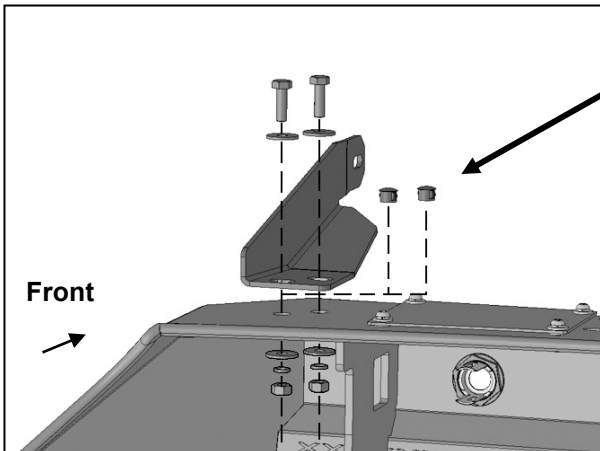

(2) Hole Plugs

(Fig 36) If Bullnose Hoop will not be used, reuse the hardware to attach the LED Brackets to top of CS1 Bumper or fill holes with the included Hole Plugs. Driver/left side installation illustrated

**(3) 12mm x 40mm Hex Bolts
(3) 12mm Lock Washers
(3) 12mm Flat Washers**

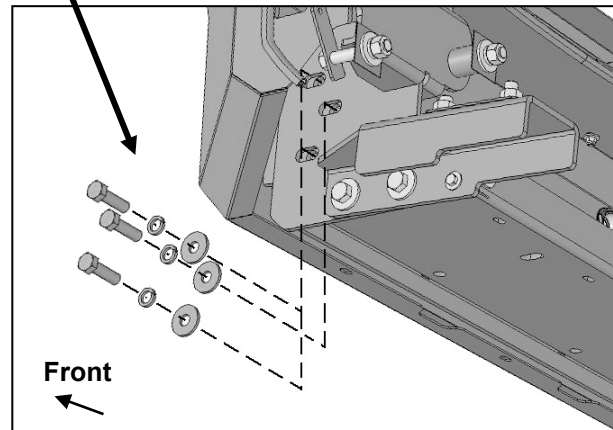

(Fig 37) Slide CS1 Bumper between mounting tabs on Winch Tray assembly

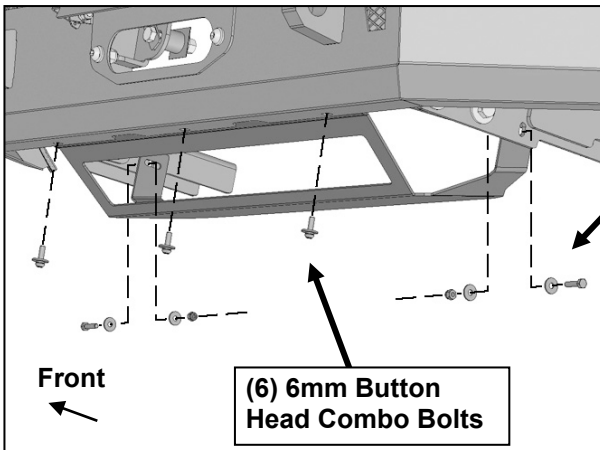

**(2) 6mm x 25mm Hex Bolts
(4) 6mm Flat Washers
(2) 6mm Nylon Lock Nuts**

(6) 6mm Button Head Combo Bolts

(Fig 38) Attach Air Deflector to back of CS1 Bumper and inside of Support Brackets

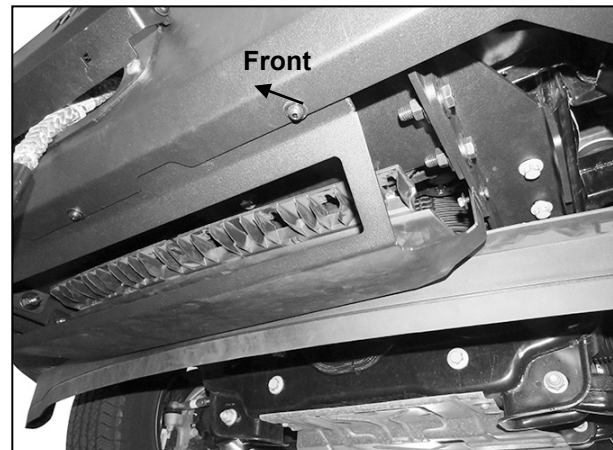

(Fig 39) Attach Air Deflector to back of CS1 Bumper and inside of Support Brackets