



INSTALLATION INSTRUCTIONS

MD-1 FRONT BUMPER

2018-20 FORD F150

T566866

PARTS LIST: T566866

1	MD-1 Front Bumper	2	8-1.25mm x 25mm Hex Bolts
1	Long Center Mesh Plate	2	8-1.25mm x 16mm Hex Bolts
2	Small Outer Mesh Plates	6	8mm x 24mm x 2mm Flat Washers
1	Driver/left "L" Bracket (center LED light)	4	8mm Lock Washers
1	Passenger/right "L" Bracket (center LED light)	2	8mm Hex Nuts
1	License Plate Bracket	10	6-1.0mm x 20mm Combo Bolts
2	Plastic Plugs for license plate mount	2	6-1.0mm x 20mm Button Head Bolts
1	Wiring Harness Kit	4	6mm x 18mm x 1.6mm Flat Washers
6	12mm Plastic Retainers	10	6mm Flange Nuts
4	10-1.5mm x 30mm Hex Bolts	2	6mm Nylon Lock Nuts
4	10mm x 20mm x 2mm Flat Washers	1	4mm Wrench
4	10mm Lock Washers	10	Nylon Wire Ties

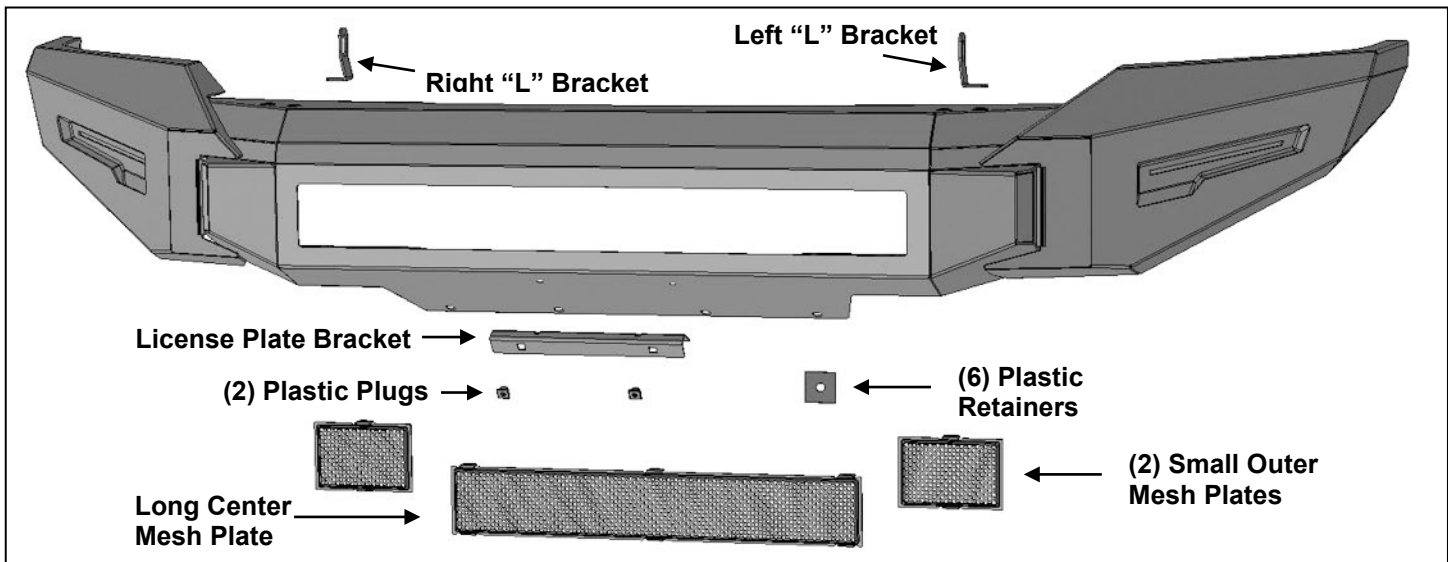

PROCEDURE:

REMOVE CONTENTS FROM BOX. VERIFY ALL PARTS ARE PRESENT. READ INSTRUCTIONS CAREFULLY BEFORE STARTING INSTALLATION. BUMPER IS HEAVY, ASSISTANCE IS HIGHLY RECOMMENDED TO AVOID POSSIBLE INJURY OR DAMAGE TO THE VEHICLE.

1. Remove the license plate and bracket, **(Figure 1)**. Remove the plastic bumper pad assembly, **(Figure 2)**. **NOTE:** Carefully pull bumper pad straight out away from bumper. Unplug and remove the adaptive cruise control, if equipped, **(Figure 3)**. **Models equipped with adaptive cruise control** must purchase a separate ACC Relocation Kit to reinstall the ACC sensor. Please follow the instructions provided in the Relocation Kit to reinstall the ACC sensor.
2. Unplug any wiring harness leading to the front bumper, **(Figure 4)**. Move all wiring harnesses away from bumper.
3. Place blocks or jack stands under the front bumper to support it during mounting bolt removal. Once the bumper has been safely supported, remove the large hex nut from the back of the driver/left bumper bracket attaching the lower bumper to the bumper bracket, **(Figure 5)**. Next, from the front of the bumper, remove the (2) factory hex nuts attaching the driver/left side of the bumper to the bumper brackets, **(Figure 6)**. **WARNING!** Assistance is required to hold the bumper in place during bolt removal to prevent the bumper from falling. Repeat this **Step** to release the passenger/right side of the bumper.
4. Carefully slide the bumper off over the tow hooks.
5. On models with bolt on frame extensions, remove the extensions from outside of frame, **(Figure 7)**. **NOTE:** On some models the factory bolts may need to be cut to remove frame extensions-removal is optional.
6. Carefully unwrap the Bumper assembly. Pull outward to unfold the passenger/right outer wing until fully extended, **(Figure 8)**. Anchor the Wing to the back of the Bumper with the included (2) 10mm x 30mm Hex Bolts, (2) 10mm Lock Washers and (2) 10mm Flat Washers, **(Figure 9)**. Leave hardware loose at this time.

**MD-1 FRONT BUMPER
2018-20 FORD F150**

Repeat this **Step** to unfold and attach the driver/left Wing to the Bumper. **IMPORTANT:** There is a small amount of adjustment in the Wings that can increase or decrease the final width of the Bumper. Loosen the (2) pivot bolts and the (2) anchor bolts and pull each Wing outward as far as possible to start, (**Figure 10**). Snug hardware but do not fully tighten at this time.

7. Determine if accessory lights, (not included), or Screen Fill Panels will be installed at this time. **NOTE:** It may be easier to install Center Fill Panels and/or lights before installing Bumper. **IMPORTANT:** On EcoBoost models, center LED Light installation that partially or fully blocks the opening in the Bumper is not recommended. Blocking the EcoBoost engine may cause overheating.

Screen Fill Panel Installation (do not install fill panels if installing lights).

- a. Select desired long center or small outer Screen Fill Panels, (**Figure 11**).
- b. Attach Screen Fill Panels as needed with the included 6mm Button Head Combo Bolts and 6mm Flange Nuts, (**Figure 11**). Fully tighten Fill Panel hardware at this time. Repeat to install all Panels as desired.

Inner center LED bar style light installation (light not included).

- a. Select the passenger/right "L" Light Bar Bracket, (**Figure 12**). **NOTE:** "L" Brackets are offset to adjust for different widths of LED Bar Lights and can be installed on either side as needed.
 - b. Attach the "L" Bracket to the slot on the back of the Bumper with (1) 8mm x 25mm Hex Bolt, (2) 8mm Flat Washers, (1) 8mm Lock Washer and (1) 8mm Hex Nut, (**Figure 12**). Repeat this Step to install the remaining "L" Bracket on the other side of the Bumper. **IMPORTANT:** The Bumper features slots designed for most 20" and 30" bar style lights. Attach the Brackets to the correct slots in the Bumper. If necessary, hold the light up to the slots to help determine correct slots to use.
 - c. Attach the light to the "L" Brackets with the hardware included with the light or the supplied (2) 8mm x 16mm Hex Bolts, (2) 8mm Lock Washers and (2) 8mm Flat Washers, (**Figure 12**). Do not fully tighten hardware at this time.
8. Remove the factory double bolt plates from the end of the frame, (**Figure 13**), and the single bolt plates from the bottom/back of the factory bumper. Select (1) double bolt plate, (**Figure 14**). Insert the bolt plate through the back of the passenger/right side mounting plate on the back of the bumper and out through the top slots, (**Figure 15**). Thread (2) 12mm Plastic Retainers onto the double bolt plate. Tighten Retainers up against the mounting plate to secure bolt plate in place, (**Figures 15 & 16**). **NOTE:** The Plastic Retainers are used to hold the bolt plates in place and help in Bumper installation. Use is not mandatory for installation. Repeat **Step** to attach (1) factory single bolt plate with (1) 12mm Plastic Retainer to the bottom slot in the bumper mounting plate, (**Figures 15 & 16**).
9. Repeat the previous **Step** to install the factory bolt plates on the driver/left side bumper mounting plate.
10. With assistance, position the Bumper Assembly up to the frame. Temporarily support the weight of the Bumper. **WARNING:** To avoid possible injury or damage to the vehicle, do not proceed until the bumper is fully and safely supported.
11. Reuse the (6) factory hex nuts to attach the Bumper to the bolt plates, (**Figure 17**). Do not fully tighten hardware at this time.
12. Level and adjust the bumper and fully tighten all hardware. **IMPORTANT:** Adjust wings on bumper as needed and fully tighten all wing pivot and mounting hardware, (**see Step 6, Figure 10**).
13. Attach the License Plate Bracket to the holes in the bumper with the included (2) 6mm x 20mm Button Head Screws, (4) 6mm Flat Washers and (2) 6mm Nylon Lock Nuts. Insert (2) Plastic Plugs into the square holes in the Bracket. Reuse the factory screws to attach the license plate to the plastic plugs, (**Figure 18**).
14. Do periodic inspections to the installation to make sure that all hardware is secure and tight.

To protect your investment, Do not use any type of polish or wax that may contain abrasives that could damage the finish. Mild soap may be used to clean the Bumper assembly.



(Fig 1) Remove license plate from Bumper

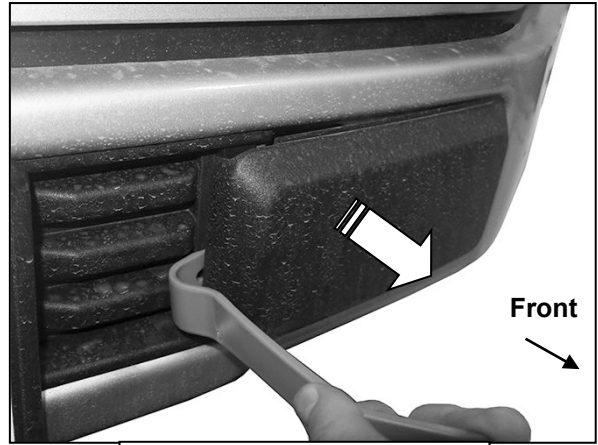

(Fig 2) Carefully pull plastic bumper pad off of bumper



(Fig 3) Remove and unplug adaptive cruise control from driver/left side of frame, if equipped

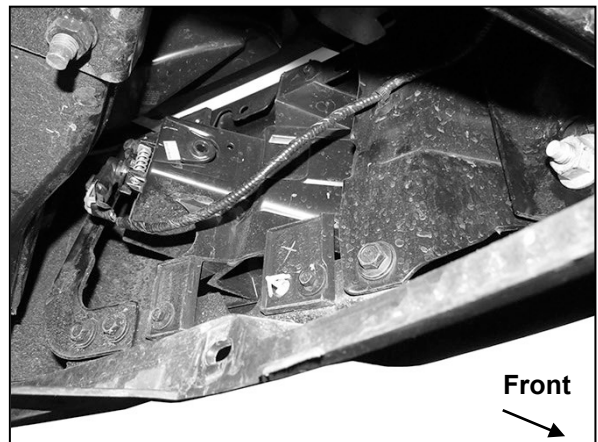

(Fig 4) Unplug and move factory wiring harness for fog lights (if equipped)

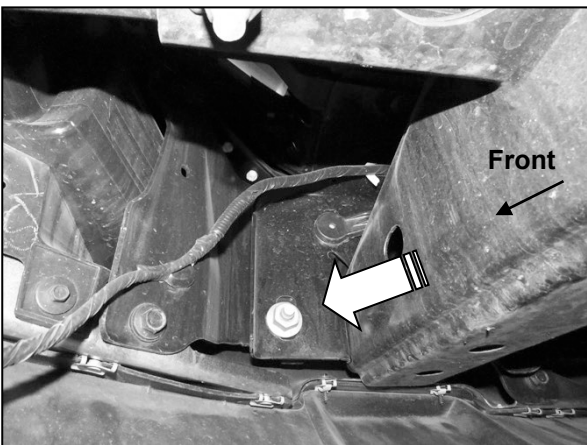

(Fig 5) Remove factory hex nut (arrow) from back of each bumper bracket

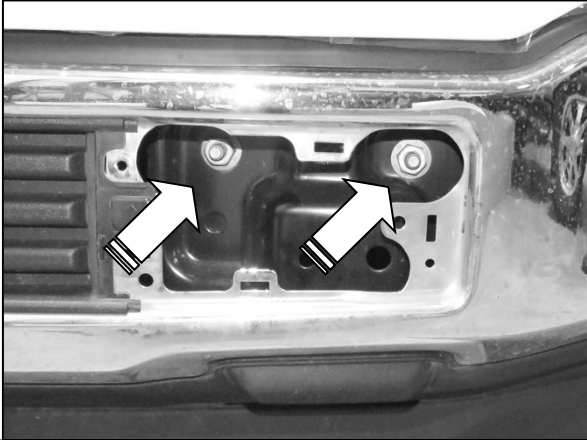

(Fig 6) Remove (2) factory hex nuts from each side

WARNING! Do not remove bumper bolts unless the bumper is properly supported on blocks or stands or it may fall.

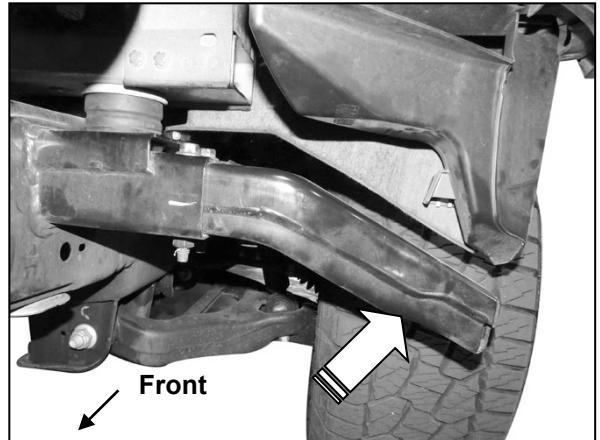

(Fig 7) Remove the factory frame extensions, if equipped (optional)

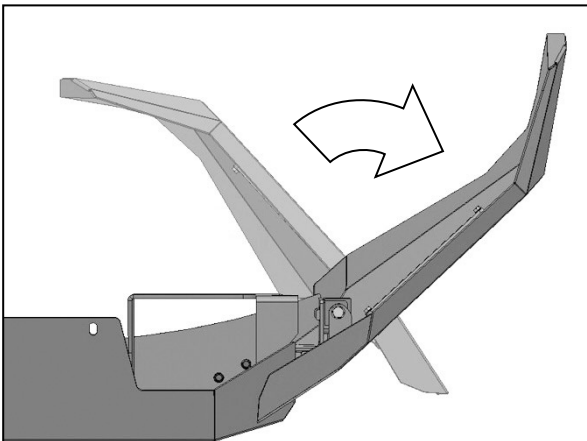

(Fig 8) Unfold outer Wings from center Bumper. Passenger/right side illustrated from below

- (2) 10mm Hex Bolts
- (2) 10mm Lock Washers
- (2) 10mm Flat Washers

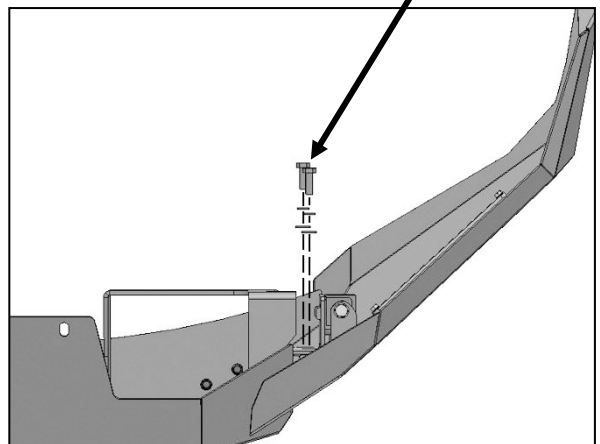

(Fig 9) Anchor outer Wings to back of center Bumper

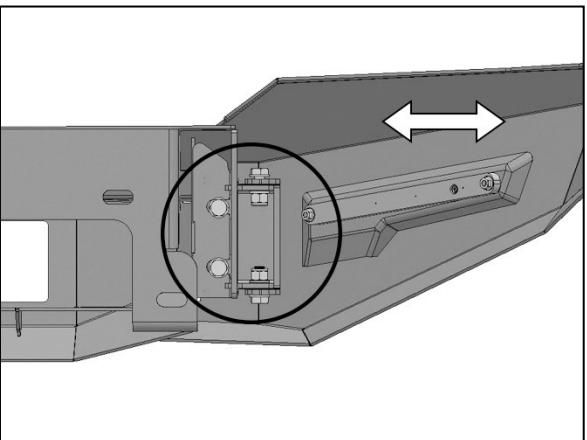

(Fig 10) Loosen hardware and pull Wing outward to widen overall Bumper Passenger/right side illustrated

**MD-1 FRONT BUMPER
2018-20 FORD F150**

**(10) 6mm Combo Bolts
(10) 6mm Flange Nuts**

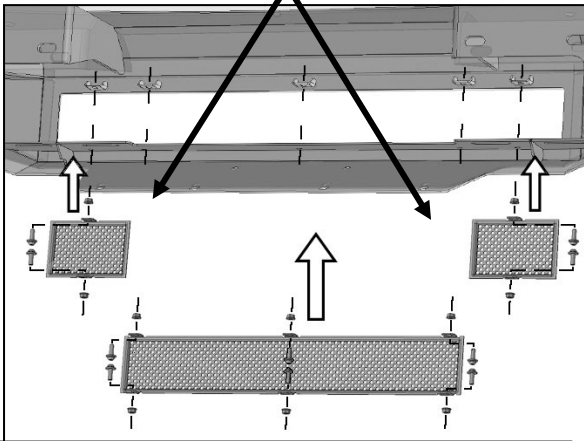

(Fig 11) Attach Inner and Center Mesh Plates to tabs on the back of the bumper as desired

**8mm x 25mm Hex Bolt
(2) 8mm Flat Washers
8mm Lock Washer
8mm Hex Nut**

**8mm x 16mm Hex Bolt
8mm Lock Washer
8mm Flat Washer**

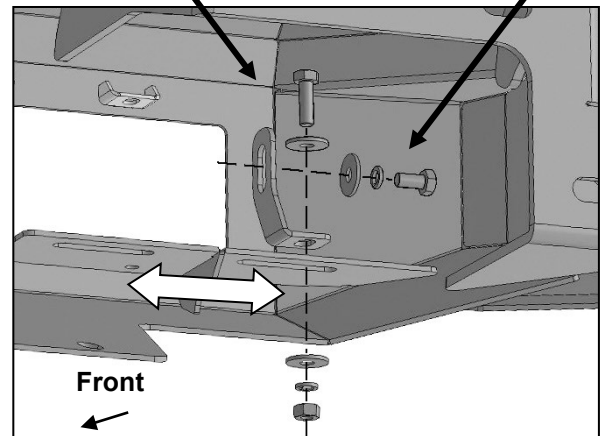

**(Fig 12) Passenger/right side "L" Bracket attached to the back of the bumper.
NOTE: Attach the "L" Bracket to the proper slot for the size of LED light**

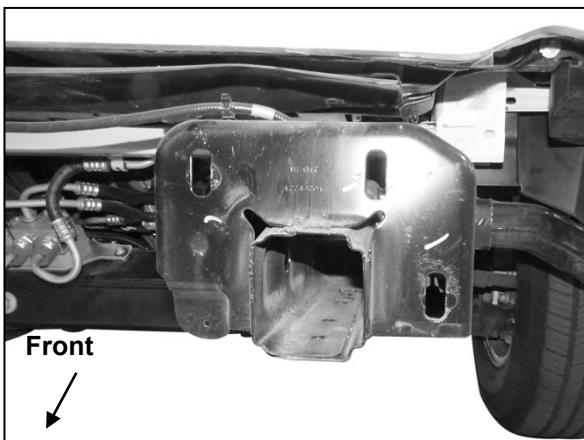

Front



(Fig 13) Remove factory double bolt plates from end of frame and single bolt plates from back/bottom of factory bumper. Driver/left side of frame pictured



(Fig 14) factory double bolt plate

**MD-1 FRONT BUMPER
2018-20 FORD F150**

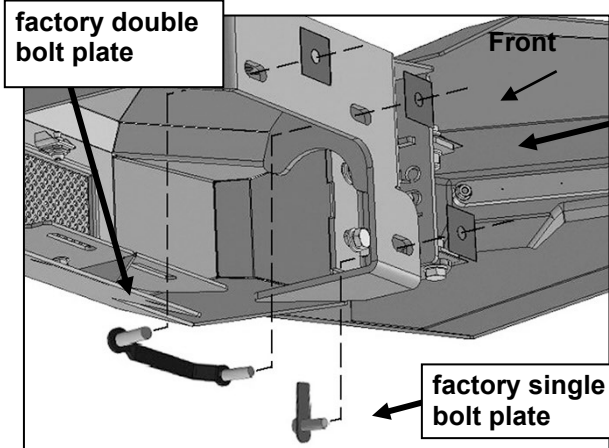

NOTE: Use (3) 12mm Plastic Retainers to hold the factory bolt plates in place in back of Bumper. Use is not mandatory for installation

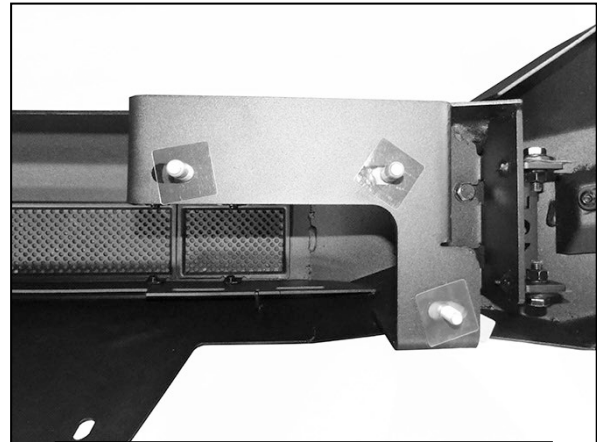

(Fig 16) Factory bolt plates installed

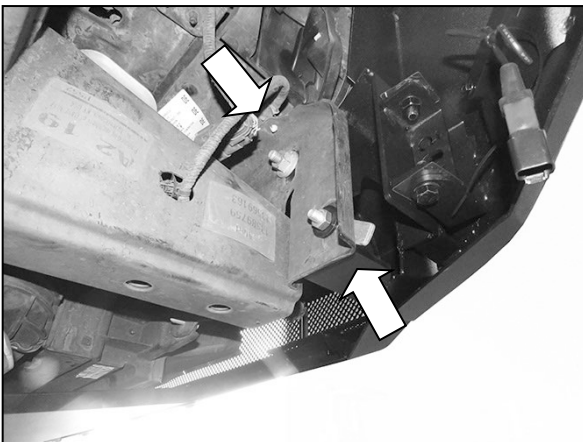

(Fig 17) Reuse factory hex nuts to attach Bumper to ends of frame. Passenger/right side pictured

- (2) 6mm x 20mm Button Head Screws**
- (4) 6mm Flat Washers**
- (2) 6mm Nylon Lock Nuts**

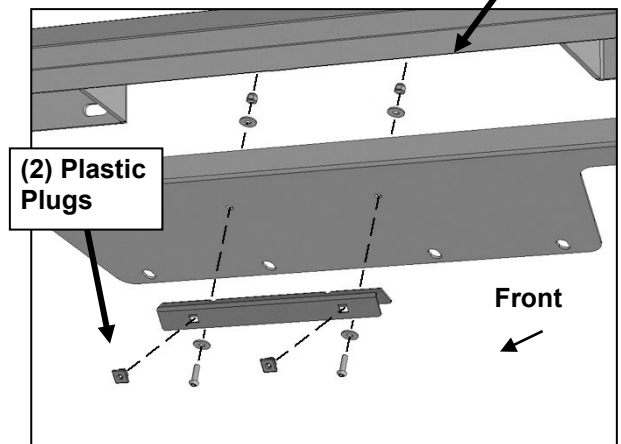

(Fig 18) Attach License Plate Bracket to Bumper



**Complete Installation
(Hoop & Light Sold Separately)**

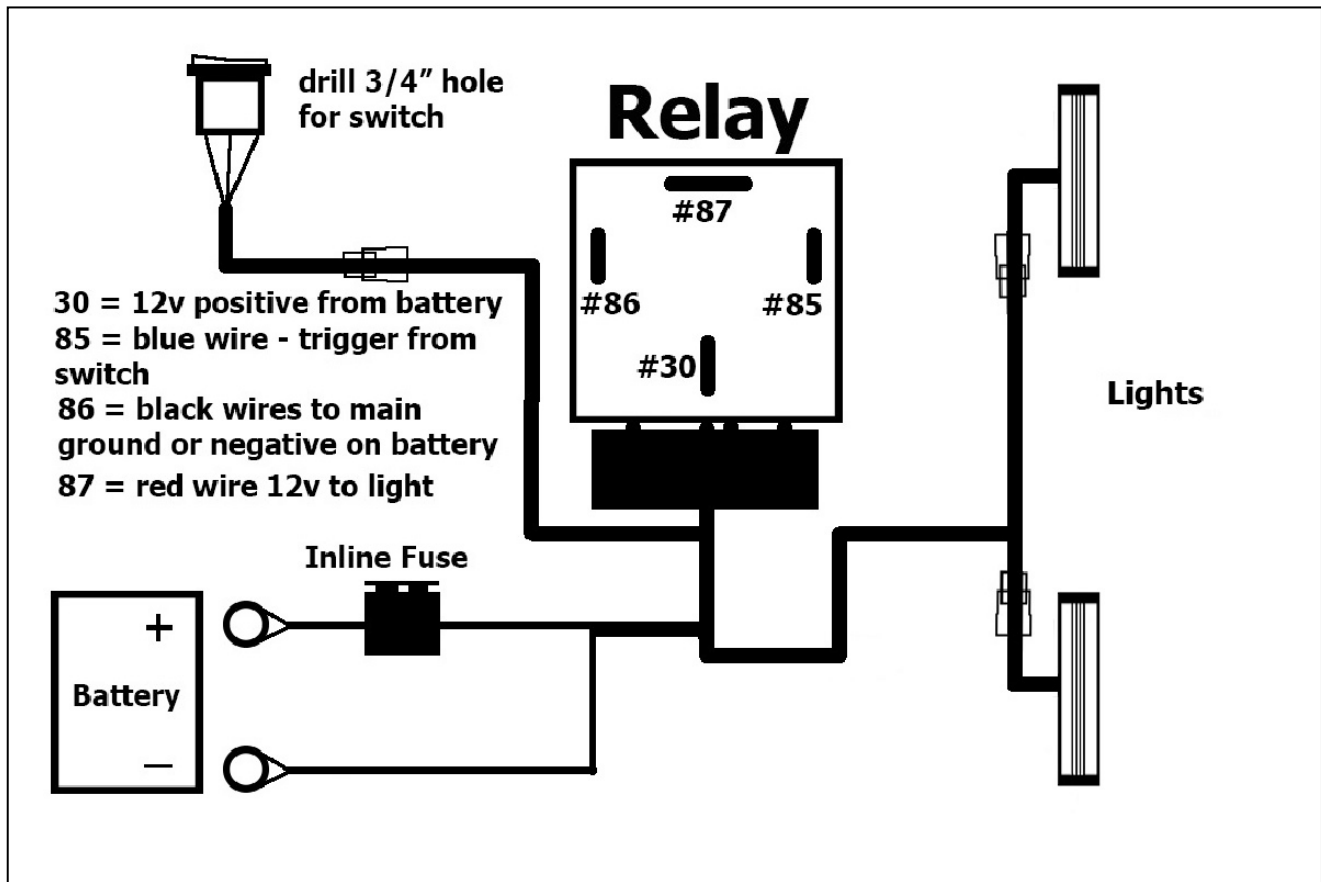

GENERAL LIGHT WIRING PROCEDURE:

1. REMOVE CONTENTS FROM BOX. VERIFY ALL PARTS ARE PRESENT. READ INSTRUCTIONS CAREFULLY. DRILLING IS REQUIRED. ELECTRICAL KNOWLEDGE IS HIGHLY RECOMMENDED.
2. Open hood and disconnect battery.
3. Unwrap preassembled wiring harness. Disconnect the plug in the harness leading to the lighted switch. Locate suitable mounting location for switch. Drill 3/4" hole in panel to mount switch. **IMPORTANT:** Do not drill any holes in panel until back of location is properly checked for clearance. Use of safety goggles is required.
4. Run switch harness through firewall on vehicle. Drill hole through firewall as required for harness plug. Highly recommend use of rubber grommet (not included) to protect harness. Feed switch harness plug through hole in firewall. Seal firewall with silicone as necessary.
5. Attach Relay and main harness to suitable location near battery (firewall or inner fender for example). Do not connect to battery at this time.
6. Attach switch plug to switch harness and tie harness away from anything that could damage harness.
7. Run the prewired light harness down to each light. Plug harness into prewired plug on each light. Tie wiring harness away from anything that could damage harness.
8. Attach the fused red positive and black negative wires on the main harness to the battery. **NOTE:** Attach black negative wire to negative terminal on battery or suitable chassis ground.
9. Reattach battery cables to battery. Installation is complete.
10. Do periodic inspections to the installation to make sure that all hardware is secure and tight and all wiring harnesses are properly secured and free from excessive movement.