



INSTALLATION INSTRUCTIONS

MD1 FRONT BUMPER

2009-2014 FORD F150 (EXCL. 10-14 RAPTOR)

PART# T570450

PARTS LIST: T570450

1	MD1 Front Bumper	4	10mm x 20mm OD x 2mm Flat Washers
1	Bumper Top Fill Panel	10	10mm Lock Washers
1	Driver/Left Frame Mounting Bracket	6	10mm Hex Nuts
1	Passenger/Right Frame Mounting Bracket	2	8mm x 25mm Hex Bolts
1	Driver/Left L-Bracket	2	8mm x 16mm Hex Bolts
1	Passenger/Right L-Bracket	6	8mm x 24mm OD x 2mm Flat Washers
1	Center Mesh Panel	4	8mm Lock Washers
2	Outer Mesh Panels	2	8mm Hex Nuts
1	License Plate Bracket	13	6mm x 20mm Button Head Combo Bolts
2	License Plate Plastic Plugs	2	6mm x 20mm Button Head Bolts
4	12mm x 45mm Hex Bolts	4	6mm x 18mm OD x 1.6mm Flat Washers
8	12mm x 37mm OD x 3mm Flat Washers	10	6mm Flange Nuts
4	12mm Lock Washers	2	6mm Nylon Lock Nuts
4	12mm Hex Nuts	1	LED Wiring Harness Kit
6	10mm x 35mm Hex Bolts	10	Wire Ties
4	10mm x 30mm Hex Bolts	1	4mm Allen Wrench
12	10mm x 27mm OD x 3mm Flat Washers		

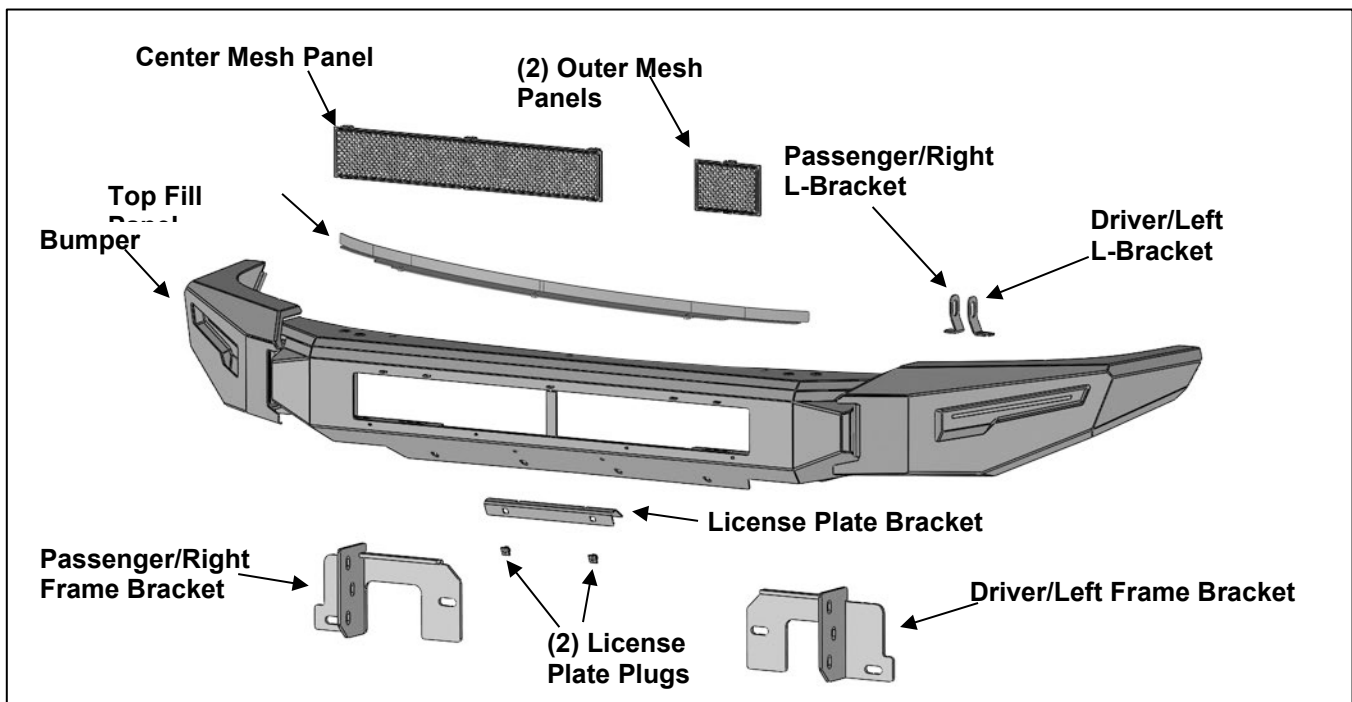

PROCEDURE:

REMOVE CONTENTS FROM BOX. VERIFY ALL PARTS ARE PRESENT. READ INSTRUCTIONS CAREFULLY BEFORE STARTING INSTALLATION. BUMPER IS HEAVY, ASSISTANCE IS HIGHLY RECOMMENDED TO AVOID POSSIBLE INJURY OR DAMAGE TO THE VEHICLE. LED BAR STYLE CENTER LIGHT MAY INTERFERE WITH AIRFLOW TO INTERCOOLER ON ECOBOOST MODELS.

1. Remove the hardware attaching the inner splash panels in the fenders to the back of the bumper, **(Figure 1)**. Also remove the license plate and bracket. On models with factory fog lights, unplug both lights and release the wiring harness from the clips attached to the back of the bumper, **(Figure 2)**. Move harness away from bumper.
2. Open the hood and remove the hardware attaching the hood release lever to the steel bracket attached to the back of the bumper, **(Figure 3)**. Also remove the screws attaching the back of the plastic fascia to the hood release bracket and remove the bracket from the bumper, **(Figure 4)**.

3. Place blocks or jack stands under the front bumper to support it during mounting bolt removal. Once the bumper has been safely supported, remove the (2) large hex nuts from the back of each bumper bracket, **(Figure 5)**. **WARNING!** Assistance is required to hold the bumper in place during bolt removal to prevent the bumper from falling. Carefully slide the bumper off over the tow hooks, if equipped.
4. On models equipped with factory tow hooks, remove the tow hooks and double nut plates from inside the ends of the frame, **(Figure 6)**.
5. Select the Driver/Left Frame Bracket. Attach the Frame Bracket to the end of the frame with (2) 12mm Hex Bolts, (4) 12mm Flat Washers, (2) 12mm Lock Washers and (2) 12mm Hex Nuts, **(Figure 7)**. Do not tighten hardware.
6. Carefully unwrap the Bumper assembly. Pull outward to unfold the passenger/right outer wing until fully extended, **(Figure 8)**. Anchor the Wing to the back of the Bumper with the included (2) 10mmx 30mm Hex Bolts, (2) 10mm Lock Washers and (2) 10mm Flat Washers, **(Figure 9)**. Leave hardware loose. Repeat this Step to unfold and attach the driver/left Wing to the Bumper. **IMPORTANT:** There is a small amount of adjustment in the Wings that can increase or decrease the final width of the Bumper. Loosen the (2) pivot bolts and the (2) anchor bolts and pull each Wing outward as far as possible to start. Snug hardware but do not fully tighten.
7. Next, select the Top Fill Panel. Attach the Fill Panel to the (3) slots along the top of the Bumper with (3) 6mm Button Head Combo Bolts, **(Figure 10)**. Tighten only the Top Fill Panel hardware.
8. Repeat **Steps 5—7** to install the passenger/right Frame Bracket.
9. Reuse the factory hardware to attach the steel hood release bracket to the mounting tabs on the back of the plastic fascia. Reattach the hood release lever to the steel bracket.
10. Determine if accessory lights, (not included), or Mesh Panels will be installed. **IMPORTANT:** It may be easier to install Center Fill Panels and/or lights before installing Bumper.

Mesh Panel Installation (do not install fill panels if installing lights).

- a. Select desired Mesh Panels.
- b. Attach Screen Fill Panels as needed with the included 6mm Button Head Combo Bolts and 6mm Flange Nuts, **(Figures 11A & 11B)**. Fully tighten Fill Panel hardware. Repeat to install all Panels as desired.

Inner center LED bar style light installation (light not included).

- a. Select the Driver/Left L-Bracket.
 - b. Attach the L-Bracket to the slot on the back of the Bumper with (1) 8mm x 25mm Hex Bolt, (2) 8mm Flat Washers, (1) 8mm Lock Washer and (1) 8mm Hex Nut, **(Figure 12)**. Repeat this Step to install the Passenger/Right L-Bracket on the other side of the Bumper. **IMPORTANT:** The Bumper features slots designed for 20" and 30" bar style lights. Attach the Brackets to the correct slots in the Bumper. If necessary, hold the light up to the slots to help determine correct slots to use and combination of Brackets.
 - c. Attach the light to the L-Brackets with the hardware included with the light or the supplied (2) 8mm x 16mm Hex Bolts, (2) 8mm Lock Washers and (2) 8mm Flat Washers or (2) 6mm x 16mm Hex Bolts, (2) 6mm Lock Washers and (2) 6mm Flat Washers, **(Figure 12)**. Do not fully tighten hardware.
11. With assistance, position the Bumper Assembly up to the mounting flanges on the Frame Brackets. Temporarily support the weight of the Bumper. **WARNING:** To avoid possible injury or damage to the vehicle, do not proceed until the bumper is fully and safely supported. Attach the Bumper to the Frame Brackets with (6) 10mm x 35mm Hex Bolts, (12) 10mm Flat Washers, (6) 10mm Lock Washers and (6) 10mm Hex Nuts, **(Figure 13)**. Do not tighten hardware.
 12. Level and adjust the bumper and fully tighten all hardware.
 13. Attach the License Plate Bracket to the holes in the bumper with the included (2) 6mm x 20mm Button Head Bolts, (4) 6mm Flat Washers and (2) 6mm Nylon Lock Nuts. Insert (2) Plastic Plugs into the square holes in the Bracket. Reuse the factory screws to attach the license plate to the plastic plugs, **(Figures 14 & 15)**.
 14. Do periodic inspections to the installation to make sure that all hardware is secure and tight.

To protect your investment, Do not use any type of polish or wax that may contain abrasives that could damage the finish. Mild soap may be used to clean the Bumper assembly.

Driver Side Installation Pictured

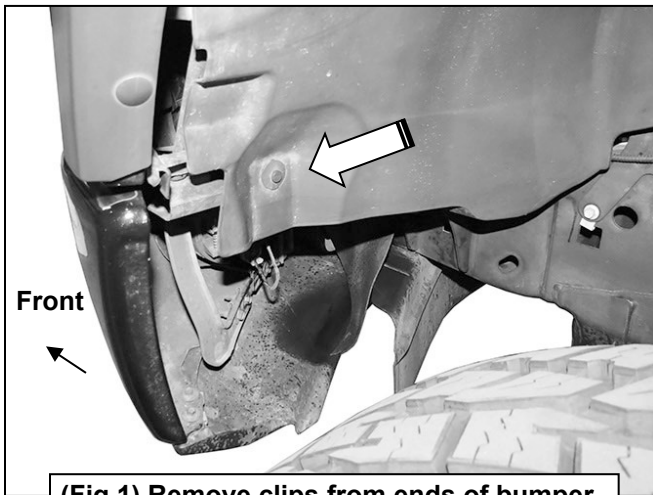

(Fig 1) Remove clips from ends of bumper



(Fig 2) Unplug factory fog light if equipped. Release clips and move wire harness away from bumper

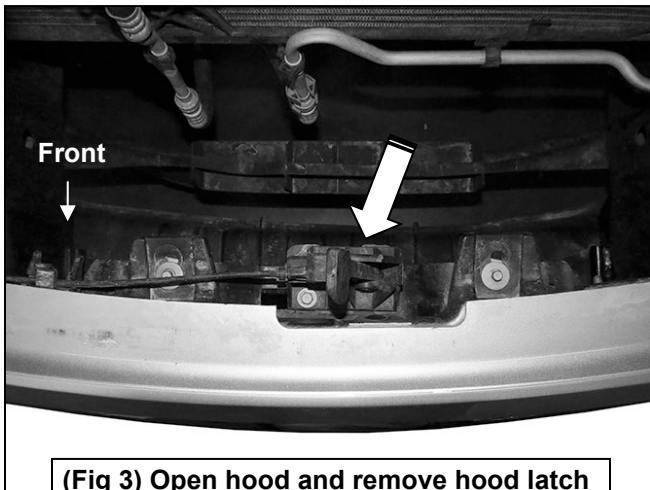

(Fig 3) Open hood and remove hood latch (arrow) from bracket on back of bumper

WARNING! Do not remove bumper bolts unless the bumper is properly supported on blocks or stands or the bumper may fall.

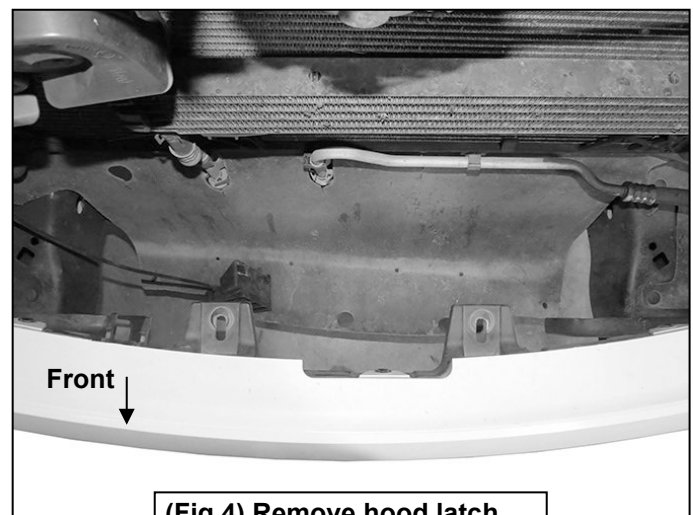

(Fig 4) Remove hood latch bracket from back of bumper

Driver Side Installation Pictured

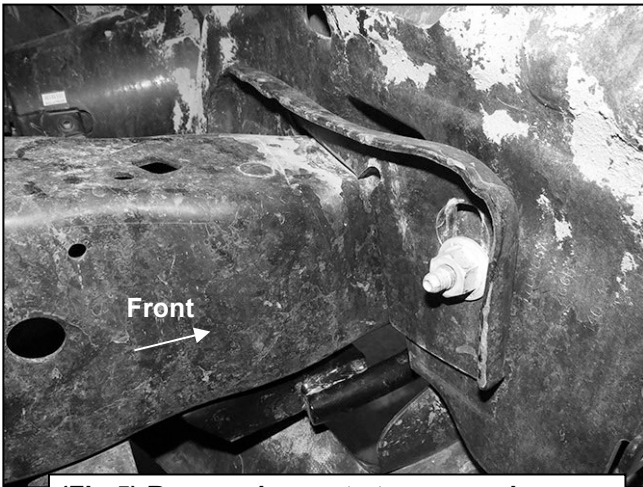

(Fig 5) Remove hex nuts to remove bumper

WARNING! Do not remove bumper bolts unless the bumper is properly supported on blocks or stands or the bumper may fall.



(Fig 6) Remove bumper assembly. Also remove tow hooks and double nut plates if equipped

- (2) 12mm Hex Bolts
- (4) 12mm Flat Washers
- (2) 12mm Lock Washers
- (2) 12mm Hex Nuts

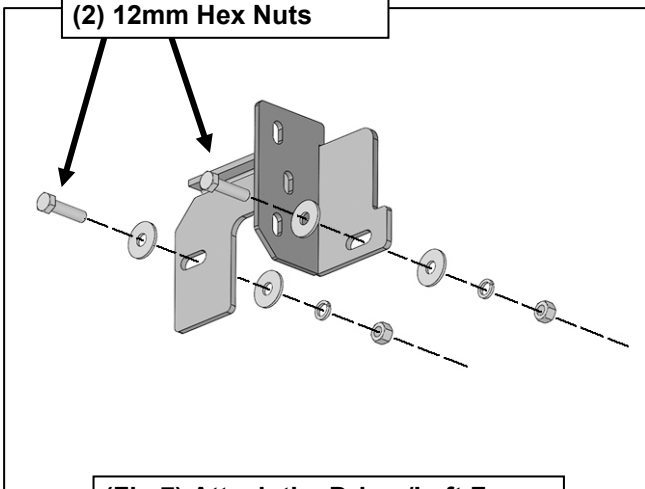

(Fig 7) Attach the Driver/Left Frame Bracket to the mounting location

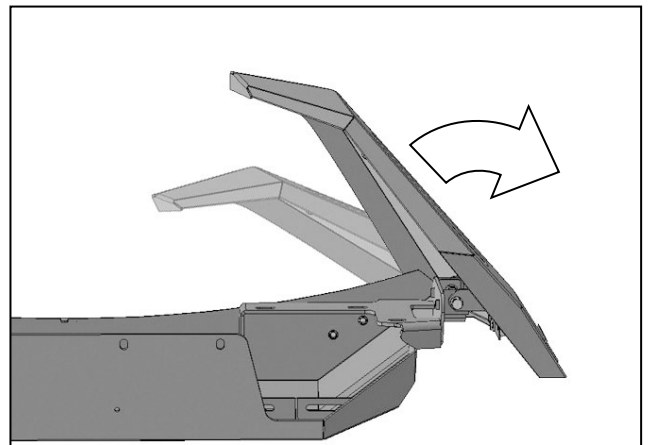

(Fig 8) Unfold outer Wings from center Bumper. Passenger/right side illustrated from below

Driver/Left Side Installation Pictured

- (2) 10mm x 30mm Hex Bolts
- (2) 10mm Lock Washers
- (2) 10mm x 20mm Flat Washers

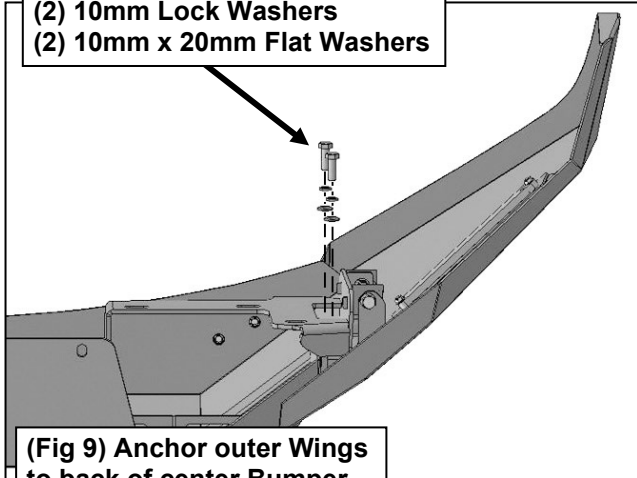

(Fig 9) Anchor outer Wings to back of center Bumper

WARNING! Do not crawl under bumper unless the bumper is properly supported on blocks or stands or the bumper may fall.

- (3) 6mm Button Head Combo Bolts

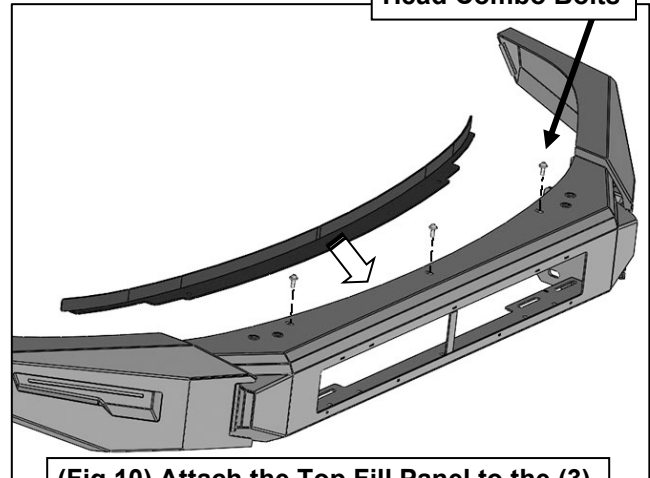

(Fig 10) Attach the Top Fill Panel to the (3) slots located along the top of the Bumper

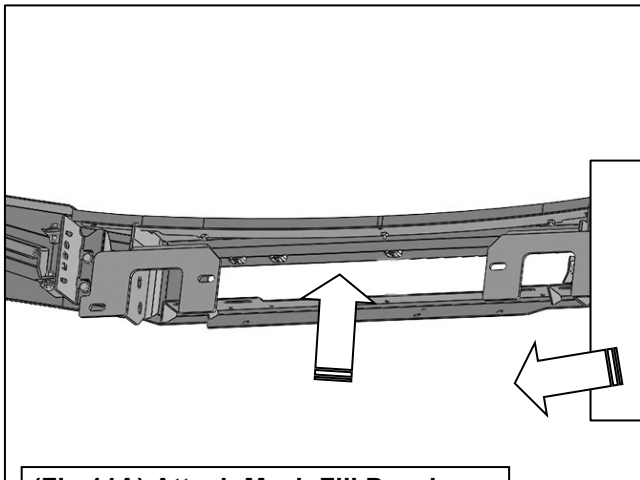

(Fig 11A) Attach Mesh Fill Panels as desired to fill unused openings for lights (lights not included).

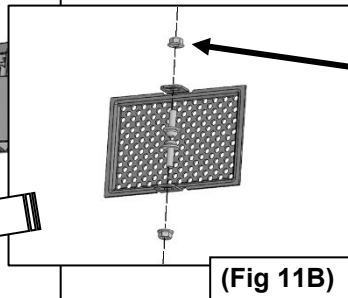

- (2) 6mm Button Head Combo Bolts
- (2) 6mm Flange Hex Nuts

(Fig 11B)

- 8mm x 25mm Hex Bolt
- (2) 8mm Flat Washers
- 8mm Lock Washer
- 8mm Hex Nut

- 6mm x 16mm Hex Bolt
- 6mm Lock Washer
- 6mm Flat Washer
- Or
- 8mm x 16mm Hex Bolt
- 8mm Lock Washer
- 8mm Flat Washer

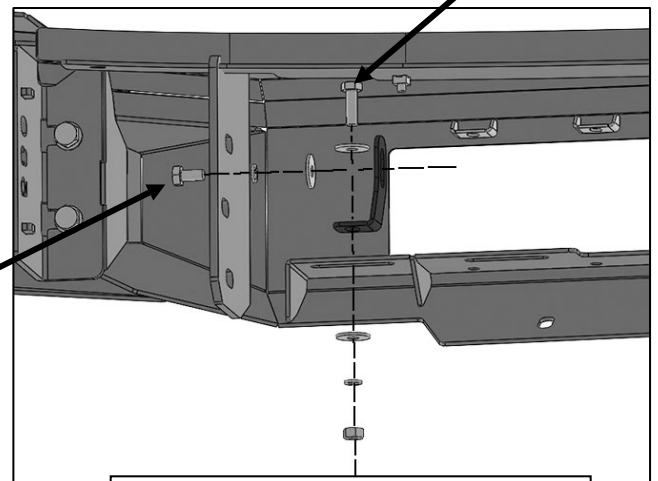

(Fig 12) Attach the L-Brackets to the back of the Bumper. Note multiple slots for different widths of lights

Driver/Left Side Installation Pictured

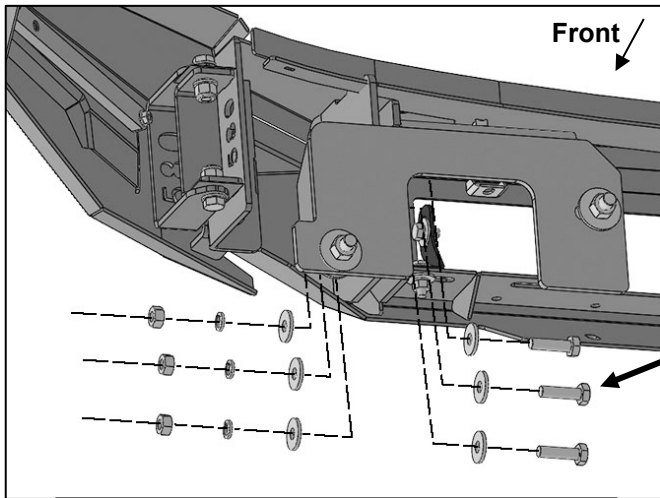

- (3) 10mm x 35mm Hex Bolts
- (6) 10mm x 37mm Flat Washers
- (3) 10mm Lock Washers
- (3) 10mm Hex Nuts

(Fig 13) Attach Bumper to Frame Brackets

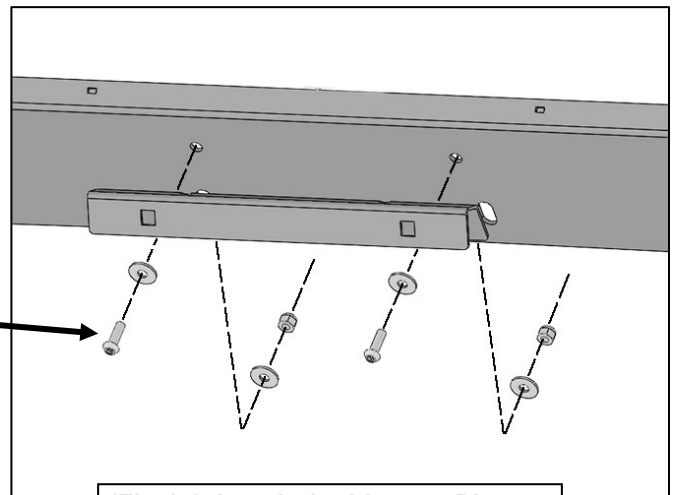

- (2) 6mm Button Head Bolts
- (4) 6mm Flat Washers
- (2) 6mm Nylon Lock Nuts

(Fig 14) Attach the License Plate Bracket to the front of the Bumper

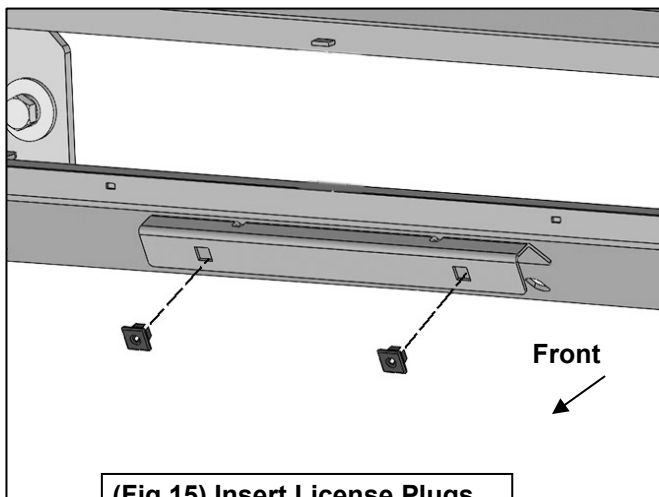

(Fig 15) Insert License Plugs into the License Plate Bracket