

**PARTS LIST:**

1	HD3 Skid Plate
2	8mm U-Clip Nuts
6	8-1.25mm x 25mm Button Head Bolts
2	8mm x 28mm x 3mm Large Flat Washers
4	8mm x 24mm x 2mm STD Flat Washers
6	8mm Lock Washers
1	5mm Allen Wrench

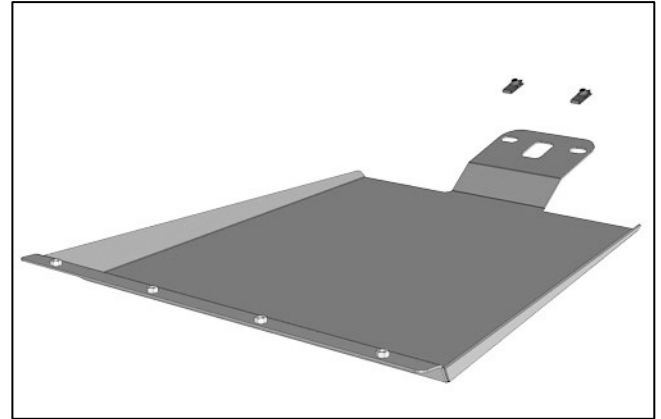

**PROCEDURE: REMOVE CONTENTS FROM BOX. VERIFY ALL PARTS ARE PRESENT. READ INSTRUCTIONS CAREFULLY BEFORE STARTING INSTALLATION.**

1. Once the HD32 Front Bumper has been installed, remove all the bolts attaching the factory skid plate to the vehicle, **(Figures 1 & 2)**.

**Models with large off-road skid plate (Fig 2):**

- a. Locate the rear skid plate mounting location on the bottom of the crossmember, **(Figure 3)**.
  - b. Slide (1) 8mm U-Clip into the driver/left side rectangular opening with the nut up towards the inside, **(Figure 4)**. Line up the threaded nut on the Clip with the round hole. Repeat to install the remaining 8mm Clip Nut in the passenger/right hole location on the crossmember.
2. With assistance, hold the HD3 Skid Plate up to the back of the Bumper. Attach the front of the HD3 Skid Plate to the Bumper with the included (4) 8mm Button Head Bolts, (4) 8mm Lock Washers and (4) 8mm x 24mm STD Flat Washers, **(Figure 5)**. Leave hardware loose at this time.
  3. Determine type of factory skid plate.

**Models with a small standard skid plate (Fig 1):**

- a. With assistance, hold the rear mount on the HD3 Skid Plate up to the bottom of the crossmember.
- b. Reuse the (2) factory bolts or the included (2) 8mm Clip Nuts, (2) 8mm Button Head Bolts, (2) 8mm Lock Washers and (2) 8mm x 28mm Large Flat Washers to reinstall the small factory skid plate over the HD3 Skid Plate, **(Figure 6)**.
- c. Adjust Skid Plate as necessary and tighten hardware at this time.

**Models with large off-road skid plate (Fig 2):**

- a. With assistance, hold the rear mount on the HD3 Skid Plate up to the bottom of the crossmember.
  - b. Attach the HD3 Skid Plate to the (2) Clip Nuts with the included (2) 8mm Button Head Bolts, (2) 8mm Lock Washers and (2) 8mm x 28mm Large Flat Washers, **(Figure 7)**.
  - c. Adjust Skid Plate as necessary and tighten hardware at this time.
  - d. Reinstall the factory large off-road skid plate over the HD3 Skid Plate and tighten hardware, **(Figure 8)**.
4. Do periodic inspections to the installation to make sure that all hardware is secure and tight.

**To protect your investment**, do not use any type of polish or wax that may contain abrasives that could damage the finish. Mild soap may be used to clean the Skid Plate.

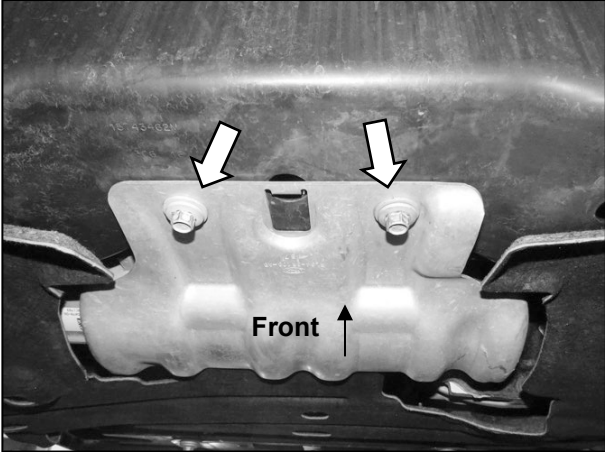

(Fig 1) Remove (2) factory bolts attaching small factory skid plate to crossmember

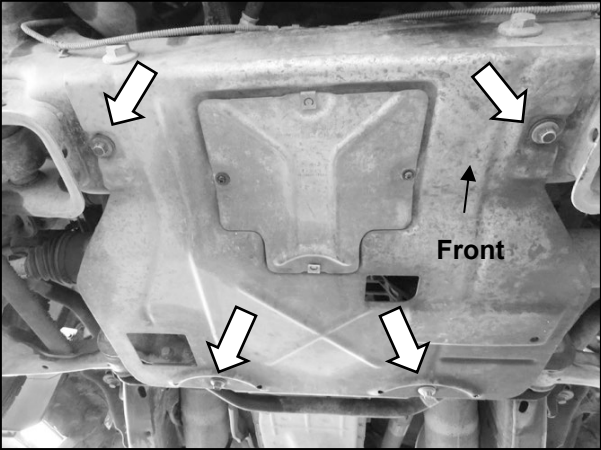

(Fig 2) Models with larger off road skid plate, remove the (4) factory bolts attaching skid plate to vehicle

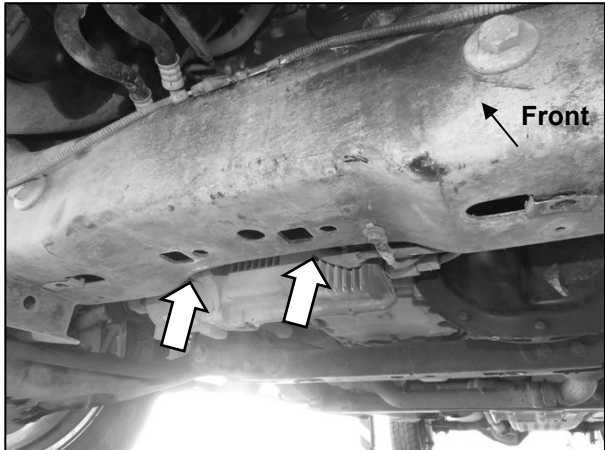

(Fig 3) Models with off road skid plate, slide the (2) 8mm Clip Nuts into the crossmember

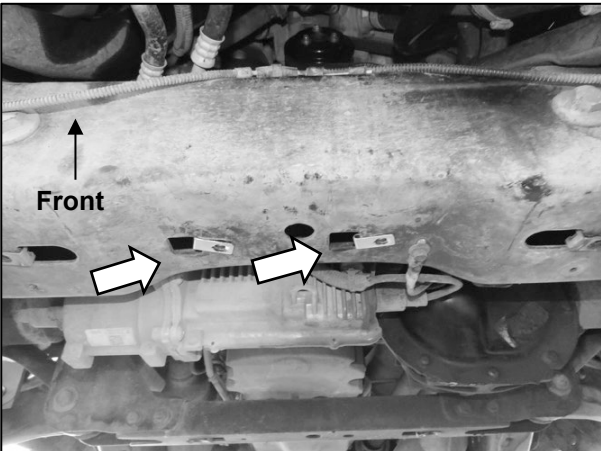

(Fig 4) Models with off road skid plate, slide the included (2) 8mm Clip Nuts into the holes in the crossmember. Line up the Clip Nut with the mounting holes (arrows)

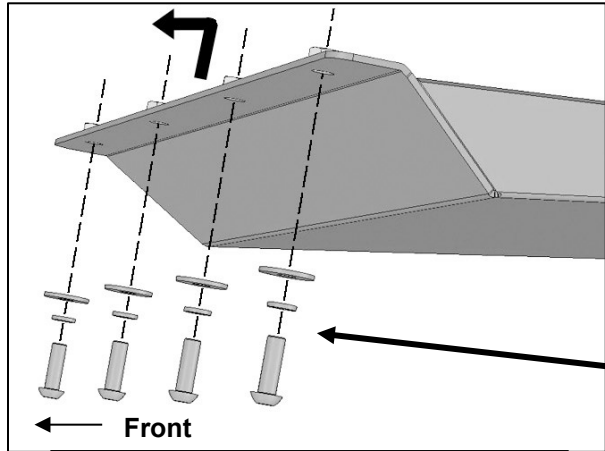

(Fig 5) Attach the front of the HD3 Skid Plate to the back of the Bumper

- (4) 8mm Button Head Bolts
- (4) 8mm Lock Washers
- (4) 8mm x 24mm STD Flat Washers

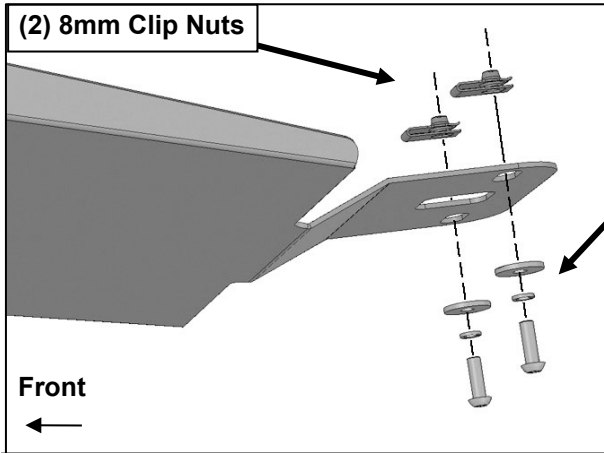

(Fig 6) Attach the rear of the HD3 Skid Plate to the Clip Nuts in the crossmember. NOTE: Models with small factory skid plate (see Figure 1), reinstall factory skid plate over HD3 Skid Plate

- (2) 8mm Button Head Bolts
- (2) 8mm Lock Washers
- (2) 8mm x 28mm Large Flat Washers

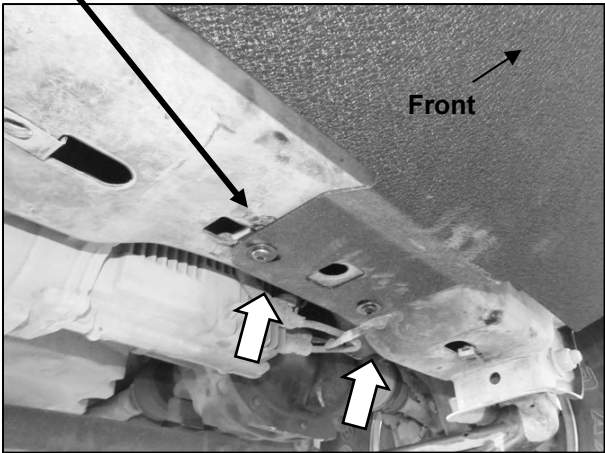

(Fig 7) Model with factory off road skid plate, attach the rear of the Skid Plate to the Clip Nuts in the crossmember. Models with small factory skid plate, reinstall factory skid plate over HD3 skid plate

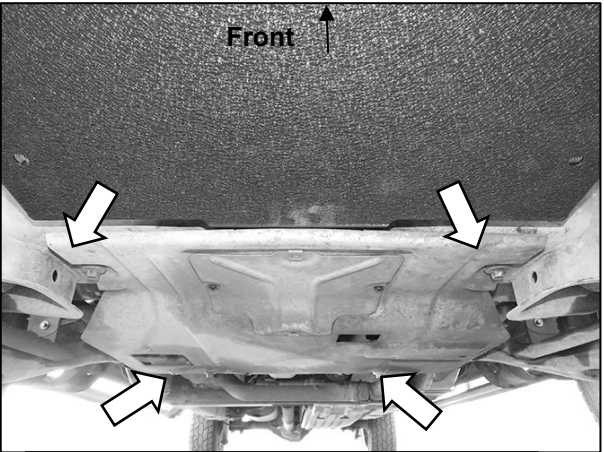

(Fig 8) Models with off road skid plate, reinstall skid plate over HD3 skid plate

