

PARTS LIST:

1	HD3 LD Front Bumper	4	8-1.25mm x 25mm Hex Bolts
1	Bumper Cover Plate	2	8-1.25mm x 16mm Hex Bolts
1	Long Center Mesh Plate	10	8mm x 24mm x 2mm Flat Washers
2	Small Outer Mesh Plates	6	8mm Lock Washers
2	"L" Brackets (center LED light)	4	8mm Hex Nuts
1	License Plate Bracket	14	6-1.0mm x 20mm Combo Bolts
2	Plastic Plugs for license plate mount	8	6mm Flange Nuts
6	12mm Plastic Retainers	1	4mm Wrench

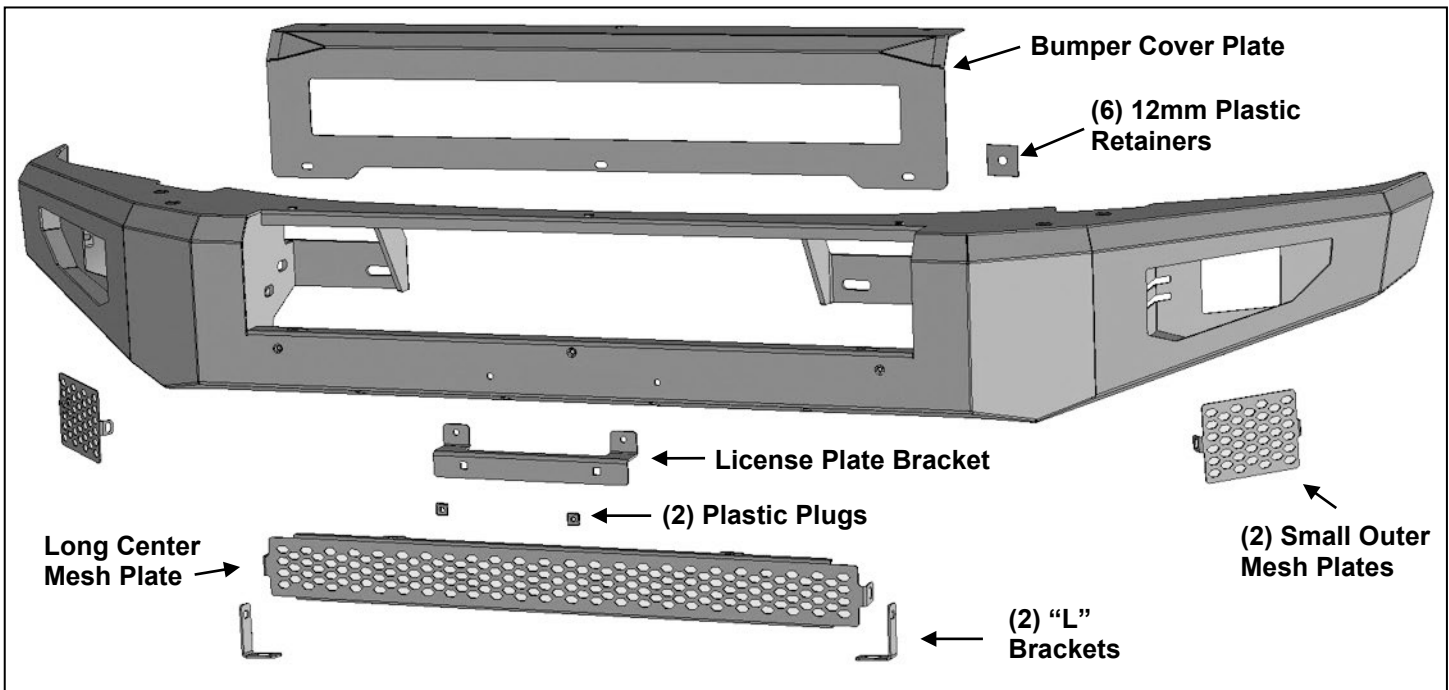

PROCEDURE:

REMOVE CONTENTS FROM BOX. VERIFY ALL PARTS ARE PRESENT. READ INSTRUCTIONS CAREFULLY BEFORE STARTING INSTALLATION. BUMPER IS HEAVY, ASSISTANCE IS HIGHLY RECOMMENDED TO AVOID POSSIBLE INJURY OR DAMAGE TO THE VEHICLE.

1. Remove the license plate and bracket, **(Figure 1)**. Remove the plastic bumper pad assembly, **(Figure 2)**. **NOTE:** Carefully pull bumper pad straight out away from bumper. Unplug and remove the adaptive cruise control, if equipped, **(Figure 3)**.
2. Unplug the fog lights, if equipped, **(Figure 4)**. Release the wiring harness from the clips attached to the back of the bumper. Move all wiring harnesses away from bumper.
3. Place blocks or jack stands under the front bumper to support it during mounting bolt removal. Once the bumper has been safely supported, remove the large hex nut, (1 per side), from the back of the bumper bracket attaching the lower bumper to the bumper bracket, **(Figure 5)**. Next, from the front of the bumper, remove the (2) factory hex nuts per side attaching the bumper to the bumper brackets, **(Figures 6 & 7)**. **WARNING!** Assistance is required to hold the bumper in place during bolt removal to prevent the bumper from falling. Carefully slide the bumper off over the tow hooks. **OPTIONAL-** On models with bolt on frame extensions, remove the extensions from outside of frame, **(Figure 8)**. **NOTE:** On some models the factory bolts may need to be cut to remove frame extensions.
4. Remove the single bolt plates from the bottom of the bumper brackets on the back of the bumper, **(Figure 9)**. **NOTE:** It may be necessary to partially disassemble the factory bumper to remove the bottom bolt plates.
5. Carefully unwrap the Bumper assembly. With assistance, position the Bumper Assembly up to the frame. Temporarily support the weight of the Bumper. **WARNING:** To avoid possible injury or damage to the vehicle, do not proceed until the bumper is fully and safely supported.

6. Reuse the (4) factory hex nuts to secure the Bumper to the factory bolt plates, **(Figures 10 & 11)**. Do not fully tighten hardware at this time.
7. Select (1) factory bolt plate from the bottom of the factory bumper, **(Figure 9)**. Insert the bolt plate through the back of the driver/left side mounting plate on the back of the bumper and out through the bottom slot, **(Figure 11)**. Repeat this **Step** to attach the remaining factory bolt plate to the bottom slot on the passenger/right bumper mounting plate.
8. Level and adjust the Bumper to the vehicle and fully tighten all hardware, **(Figure 12)**.
9. Attach the Top Cover to the front and top of the Bumper with the included (6) 6mm Combo Bolts, **(Figure 13)**.
10. Determine if accessory lights, (not included), or Screen Fill Panels will be installed at this time.
IMPORTANT: On Ecoboost models, center LED Light installation is not recommended in the Bumper. Blocking the Ecoboost intercooler may cause overheating.

Outer Screen Fill Panel Installation (do not install fill panels if installing lights).

- a. Attach (1) Screen Fill Panel to the tabs on the back of the driver/left side of the Bumper with the included (2) 6mm Button Head Combo Bolts and (2) 6mm Flange Nuts, **(Figure 14)**. Fully tighten Fill Panel hardware at this time. Repeat this **Step** to install the remaining Fill Panel on the passenger/right side of the Bumper.

Outer LED cube style light installation, (lights not included).

- a. Attach lights to the mounting tabs at the outer ends of the Bumper, **(Figure 14)**.
- b. Follow the light manufacturer's instruction to properly wire lights once Bumper is installed.

Inner Mesh Fill Panel installation.

- a. Select (1) "L" Light Bar Bracket. Attach the "L" Bracket to the slot on the back of the Bumper with (1) 8mm x 25mm Hex Bolt, (2) 8mm Flat Washers, (1) 8mm Lock Washer and (1) 8mm Hex Nut, **(Figure 15)**. Repeat this **Step** to install the remaining "L" Bracket on the passenger/right side of the Bumper.
- b. Attach the Fill Panel to the "L" Brackets with the included (2) 8mm x 25mm Hex Bolts, (4) 8mm Flat Washers, (2) 8mm Lock Washers and (2) 8mm Hex Nuts, **(Figure 16)**. Do not fully tighten hardware at this time.
- c. Attach the top of the Fill Panel to the tabs on the back of the Top Cover with the included (2) 6mm Button Head Combo Bolts and (2) 6mm Flange Nuts, **(Figure 16)**.
- d. Adjust the Fill Panel to the Cover and fully tighten all hardware.

Inner center LED bar style light installation (light not included).

- a. Select (1) "L" Light Bar Bracket. Attach the "L" Bracket to the slot on the back of the Bumper with (1) 8mm x 25mm Hex Bolt, (2) 8mm Flat Washers, (1) 8mm Lock Washer and (1) 8mm Hex Nut, **(Figure 17)**. Repeat this **Step** to install the remaining "L" Bracket on the passenger/right side of the Bumper. **IMPORTANT:**
 - b. Attach the light to the "L" Brackets with the hardware included with the light or the supplied (2) 8mm x 16mm Hex Bolts, (2) 8mm Lock Washers and (2) 8mm Flat Washers, **(Figure 17)**. Do not fully tighten hardware at this time. Do not install Mesh Fill Panel with light.
11. Attach the License Plate Bracket to the holes in the bumper with the included (2) 6mm x 20mm Button Head Screws, (4) 6mm Flat Washers and (2) 6mm Nylon Lock Nuts, **(Figure 18)**. Insert (2) Plastic Plugs into the square holes in the Bracket. Reuse the factory screws to attach the license plate.
 12. Do periodic inspections to the installation to make sure that all hardware is secure and tight.

To protect your investment, Do not use any type of polish or wax that may contain abrasives that could damage the finish. Mild soap may be used to clean the Bumper assembly.

Driver/left Side Installation Pictured



(Fig 1) Remove license plate from Bumper

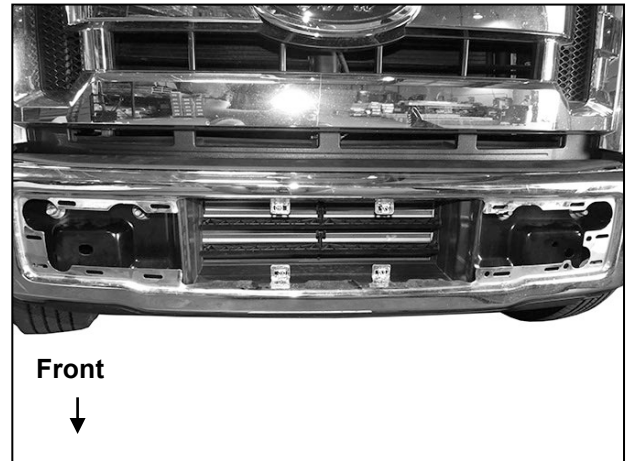

(Fig 2) Remove the plastic bumper pad from the front of the Bumper

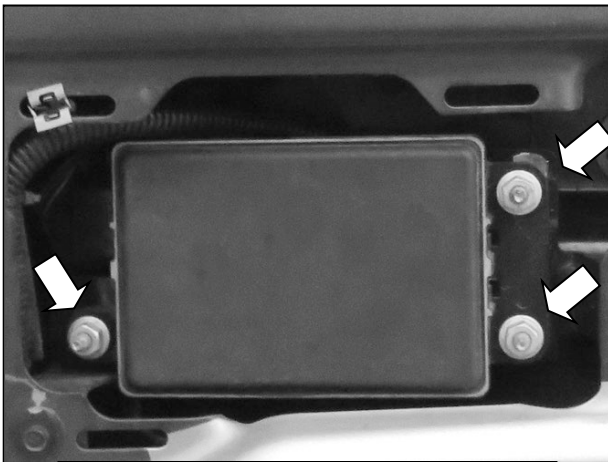

(Fig 3) Remove and unplug adaptive cruise control from driver/left side of frame, if equipped

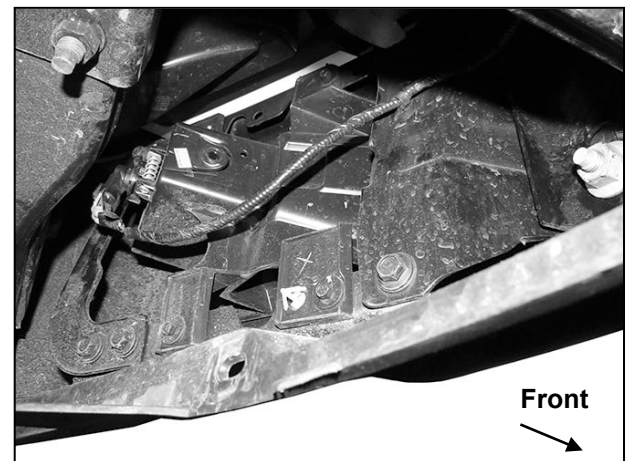

(Fig 4) Unplug and move factory wiring harness for fog lights (if equipped)

Driver/left Side Installation Pictured

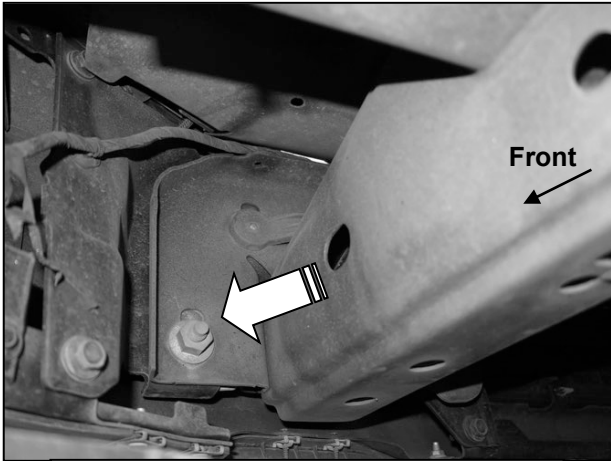

(Fig 5) Remove factory hex nut (arrow) from back of bumper bracket

WARNING! Do not remove bumper bolts unless the bumper is properly supported on blocks or stands or it may fall.

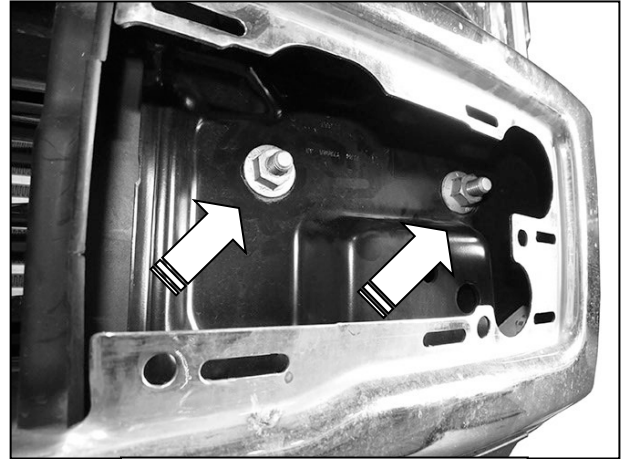

(Fig 6) Remove the (2) factory hex nuts from each side

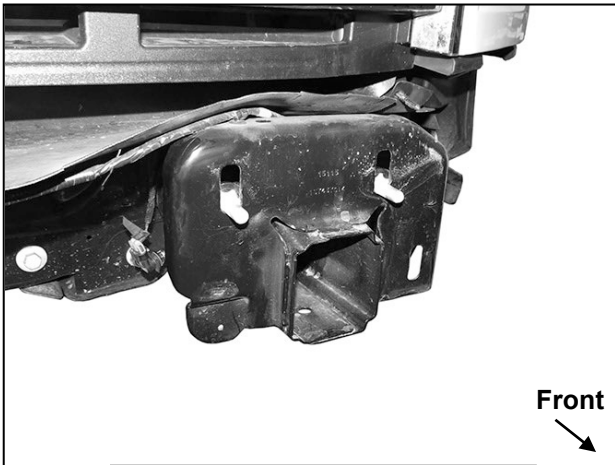

(Fig 7) Remove factory bumper



(Fig 8) Optional, remove the factory frame extensions, if equipped

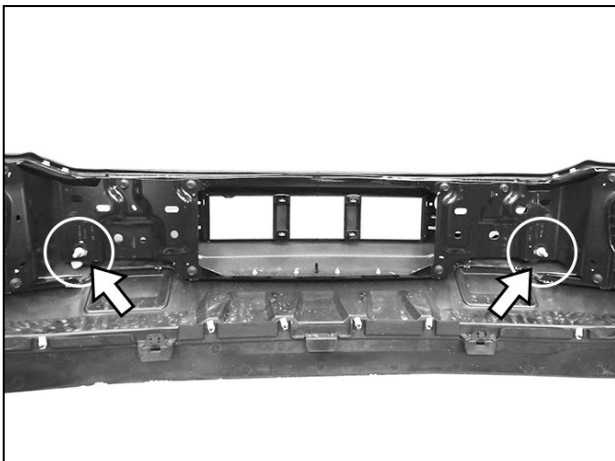

(Fig 9) Remove the bolt plates from the bottom of the factory bumper (arrows)

Driver/left Side Installation Pictured

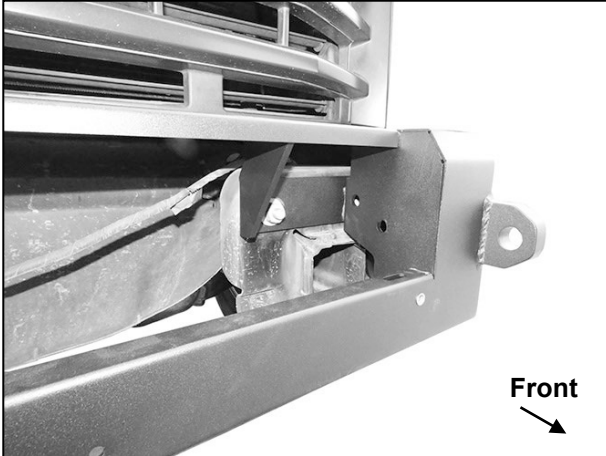

(Fig 10) Reuse the factory hex nuts to attach the Bumper to the factory double bolt plate

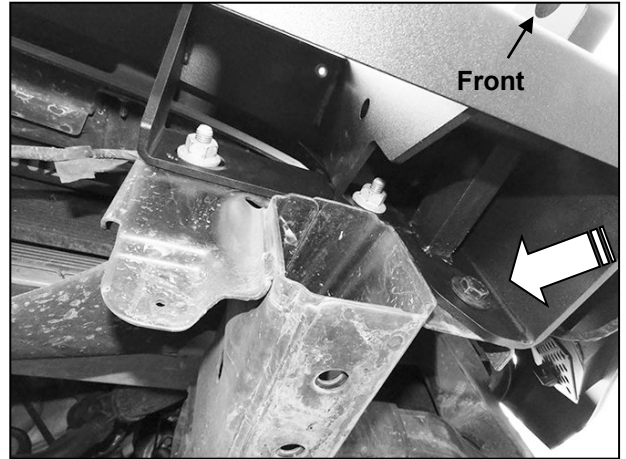

(Fig 11) Reuse the factory hex nuts to attach the Bumper to the factory double bolt plate. Reuse the factory single bolt plate to attach bottom of Bumper to frame (arrow)



(Fig 12) Center and align the Bumper to the vehicle and fully tighten all mounting hardware. (Hoop pictured not included)

(6) 6mm Combo Bolts

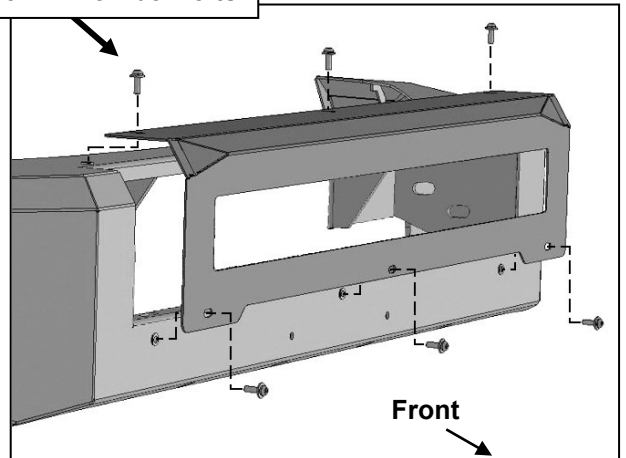

(Fig 13) Attach Bumper Cover Plate

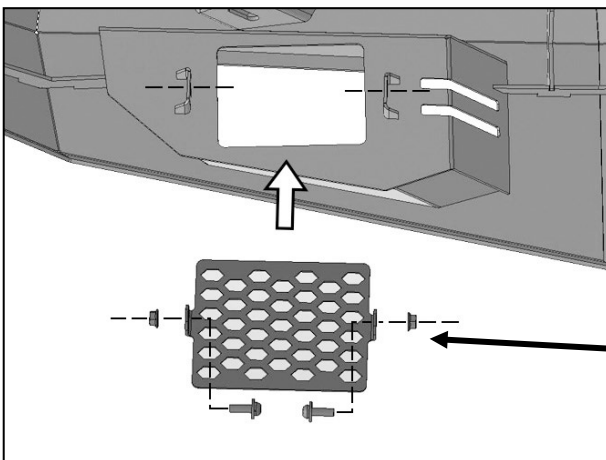

**(2) 6mm Combo Bolts
(2) 6mm Flange Nuts**

(Fig 14) Attach the Outer Mesh Panels to the tabs on the back of the Bumper

Driver/left Side Installation Pictured

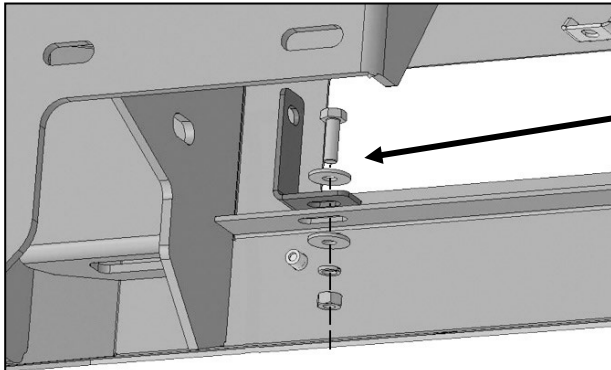

8mm x 25mm Hex Bolt
(2) 8mm Flat Washers
8mm Lock Washer
8mm Hex Nut

(2) 6mm Combo Bolts
(2) 6mm Flange Nuts

Front

(Fig 15) Attach (1) "L" Bracket to the back of the driver/left side of the Bumper

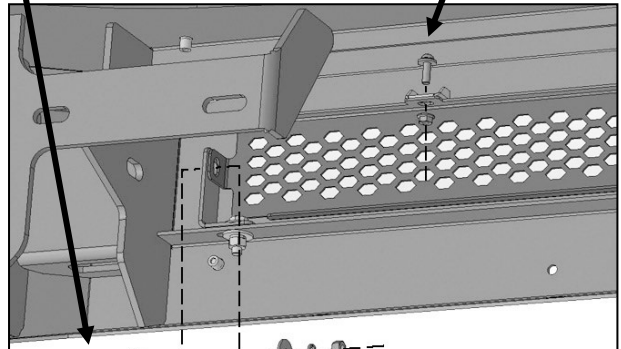

(Fig 16) Attach Center Fill Panel to "L" Brackets and tabs on the back of the Cover Plate

8mm x 25mm Hex Bolt
(2) 8mm Flat Washers
8mm Lock Washer
8mm Hex Nut

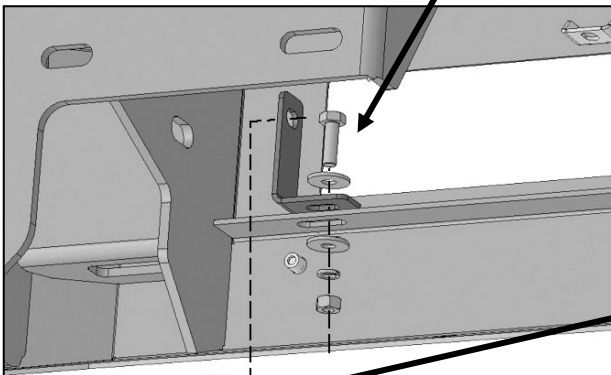

8mm x 16mm Hex Bolt
8mm Lock Washer
8mm Flat Washer

(2) 6mm Combo Bolts
(2) 6mm Flange Nuts

Front

(Fig 17) LED bar style light installation: Attach (2) "L" Brackets to the slots in the back of the Bumper. Attach light to "L" Brackets

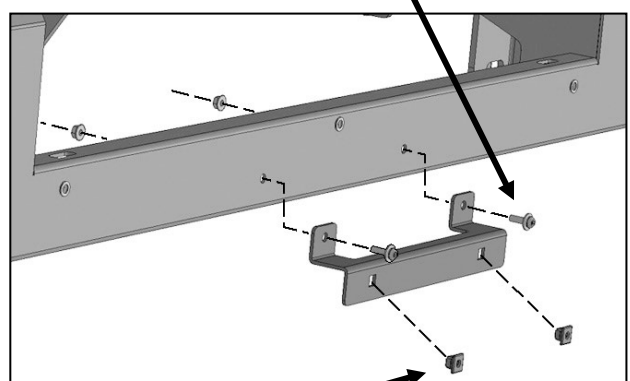

(2) Plastic Plugs

(Fig 18) Attach License Plate Bracket to front of Bumper