

**PARTS LIST:**

1	HD4 LD Push Bar	8	12mm Hex Nuts
1	Driver/left PB Shackle Mount	2	8-1.25mm x 25mm Combo Bolts
1	Passenger/right PB Shackle Mount	4	8-1.25mm x 25mm Button Head Bolts
1	Driver/left Override Tube	2	8-1.25mm x 25mm Hex Bolts
1	Passenger/right Override Tube	2	8-1.25mm x 16mm Hex Bolts
1	Driver/left "L" Light Bracket	10	8mm x 24mm x 2mm STD Flat Washers
1	Passenger/right "L" Light Bracket	4	8mm x 16mm x 1.6mm Small Flat Washers
6	12mm x 32mm x 3mm Flat Washers	8	8mm Lock Washers
2	12mm x 24mm x 2.5mm Flat Washers	6	8mm Hex Nuts
8	12mm Lock Washers	1	5mm Wrench

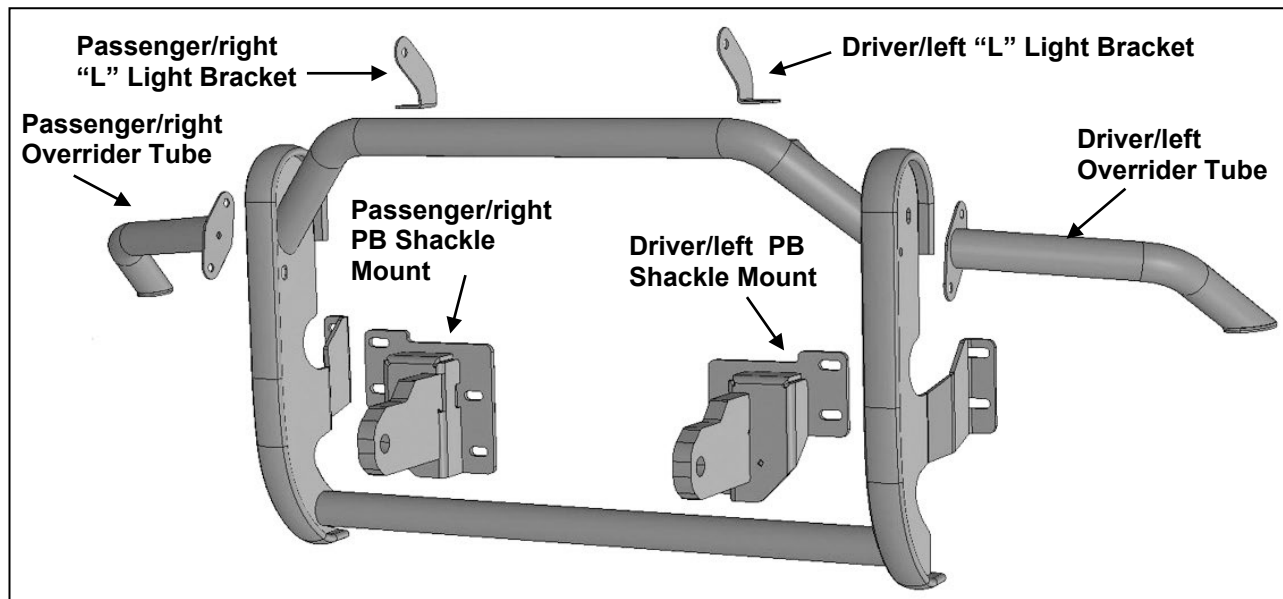

**PROCEDURE:**

**REMOVE CONTENTS FROM BOX. VERIFY ALL PARTS ARE PRESENT. READ INSTRUCTIONS CAREFULLY BEFORE STARTING INSTALLATION. ASSISTANCE IS RECOMMENDED TO AVOID POSSIBLE INJURY OR DAMAGE TO THE VEHICLE.**

1. Follow the instructions to install and align the HD4 LD Bumper to the vehicle. **NOTE:** Shackle Mounts will be substituted. Once Bumper is aligned and centered on the vehicle, remove both Shackle Mounts, **(Figures 1—3)**.
2. Select the driver/left Push Bar Shackle Mount Bracket, **(Figure 4)**. Follow the directions included with the Bumper and attach the driver/left side of the Shackle Mount to the threaded stud on the Bumper mount with the included (1) 12mm x 32mm Large Flat Washer, (1) 12mm Lock Washer and (1) 12mm Hex Nut, **(Figure 4)**. Reuse (1) Single Bolt Plate and insert the Bolt Plate into the inner mounting hole above the threaded stud. Secure the Bolt Plate to the frame with the included (1) 12mm x 32mm Large Flat Washer, (1) 12mm Lock Washer and (1) 12mm Hex Nut, **(Figure 4)**. Leave hardware loose. Repeat this **Step** to attach the passenger/right PB Shackle Mount.
3. With assistance, position the Push Bar Assembly up to the outer slots in the PB Shackle Mounts, **(Figure 5)**. Next reuse (1) Double Bolt Plate and insert the Bolt Plate through the outer holes in the Push Bar and Shackle Mount Bracket, **(Figure 5)**. Secure the Double Bolt Plate with the included (1) 12mm x 24mm Small Flat Washer, (1) 12mm Lock Washer and (1) 12mm Hex Nut, (1) 12mm x 32mm Large Flat Washer, (1) 12mm Lock Washer and (1) 12mm Hex Nut, **(Figures 6 & 7)**. Leave hardware loose. Repeat this **Step** to attach the passenger/right side of the Push Bar.
4. Level and adjust the Push Bar to the vehicle and fully tighten all hardware, **(Figure 8)**.

5. Select the driver/left Override Tube, (**Figure 9**). Remove the Rubber Plug from the top of the Bumper. Attach the flange on the Override Tube to the upright on the Push Bar with the included (2) 8mm x 25mm Button Head Bolts, (2) 8mm x 16mm Small Flat Washers (outside), (2) 8mm x 24mm STD Flat Washers (inside), (2) 8mm Lock Washers and (2) 8mm Hex Nuts, (**Figure 9**). Attach the end of the Override Tube to the top of the Bumper with the included (1) 8mm x 25mm Combo Hex Bolt, (**Figures 10 & 11**). Repeat this **Step** to install the passenger/right Override Tube.
6. Determine if accessory light, (not included), will be installed at this time. **NOTE:** Push Bar assembly is designed to be compatible with most Bar Style LED lights with a maximum of 8mm or 5/16" mounting hardware. Modifying the Push Bar assembly for hardware larger than 8mm (5/16") will damage the finish and is not recommended.  
**LED bar style light installation (light not included).**
  - a. Measure mounting slot width on Push Bar before purchasing light to verify fitment.
  - b. Select the driver/left "L" Light Bar Bracket, (**Figure 12**). **NOTE:** "L" Brackets are offset to adjust for different widths of LED Bar Lights and can be installed on either side and above or below as needed.
  - c. Attach the "L" Bracket to the slot on the back of the Bull Nose assembly with (1) 8mm x 25mm Hex Bolt, (2) 8mm Flat Washers, (1) 8mm Lock Washer and (1) 8mm Hex Nut, (**Figure 12**). Repeat this Step to install the remaining "L" Bracket. **IMPORTANT:** The Bull Nose assembly features slots designed for top or hanging light installation.
  - d. Attach the light to the "L" Brackets with the included (2) 8mm x 16mm Hex Bolts, (2) 8mm Lock Washers and (2) 8mm Flat Washers or use the hardware included with the light, (**Figure 12**). Do not fully tighten hardware at this time.
7. Reinstall the U-Cover Plates, (**Figure 13**).
8. Do periodic inspections to the installation to make sure that all hardware is secure and tight.

**To protect your investment,** Do not use any type of polish or wax that may contain abrasives that could damage the finish. Mild soap may be used to clean the Bumper and Push Bar assembly.

### Driver/left Side Installation Pictured

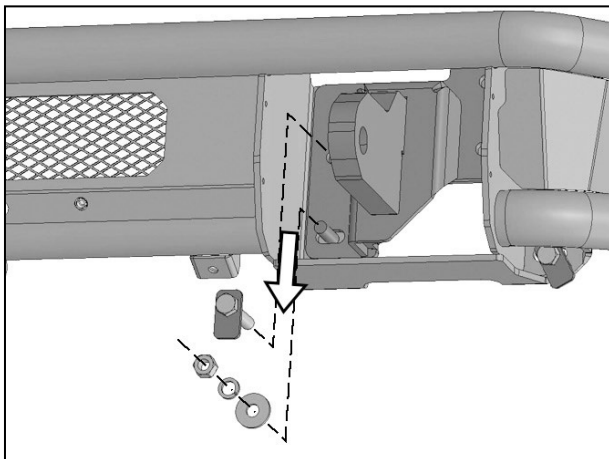

(Fig 1) Remove inner Single Bolt Plate and hardware on mounting stud

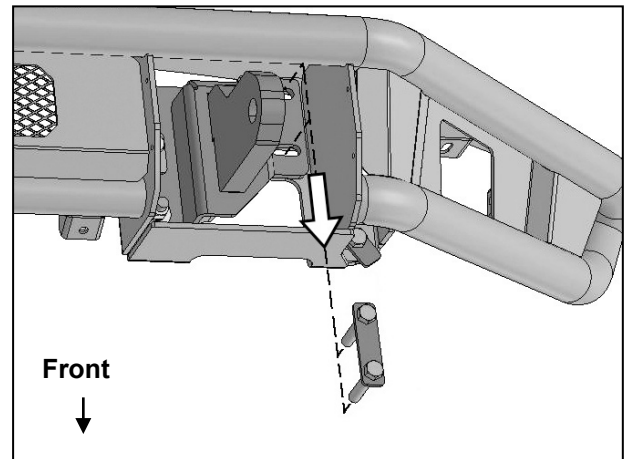

(Fig 2) Remove Outer Double Bolt Plate

**Driver/left Side Installation Pictured**

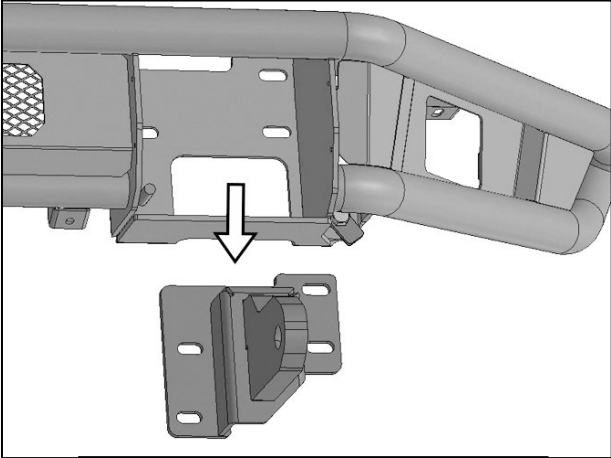

**(Fig 3) Remove standard Shackle Mounts supplied with HD4 Bumper**

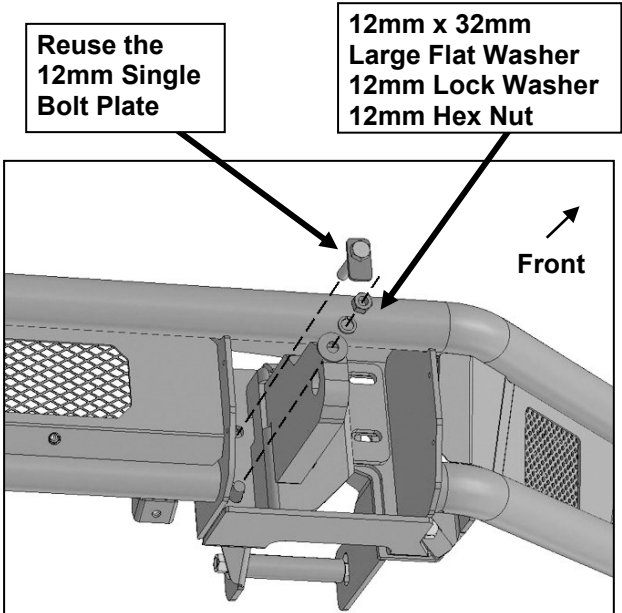

**(Fig 4) Reuse the Single Bolt Plate to attach the inner side of the Push Bar (PB) Shackle to the Bumper**

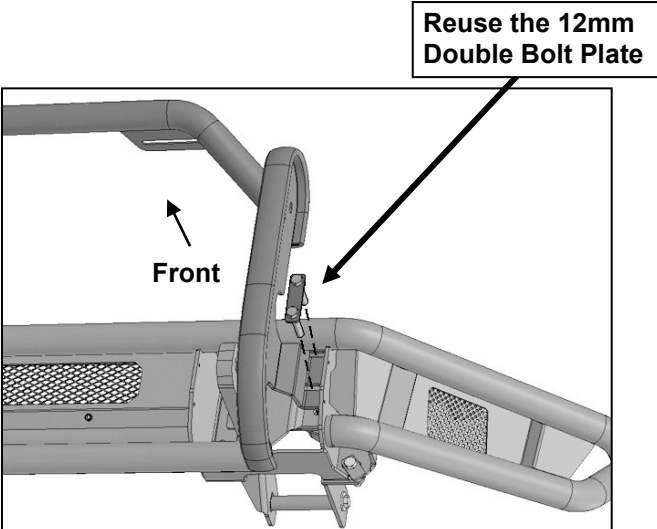

**(Fig 5) Reuse the outer Double Bolt Plate to attach the Push Bar to the PB Shackle**

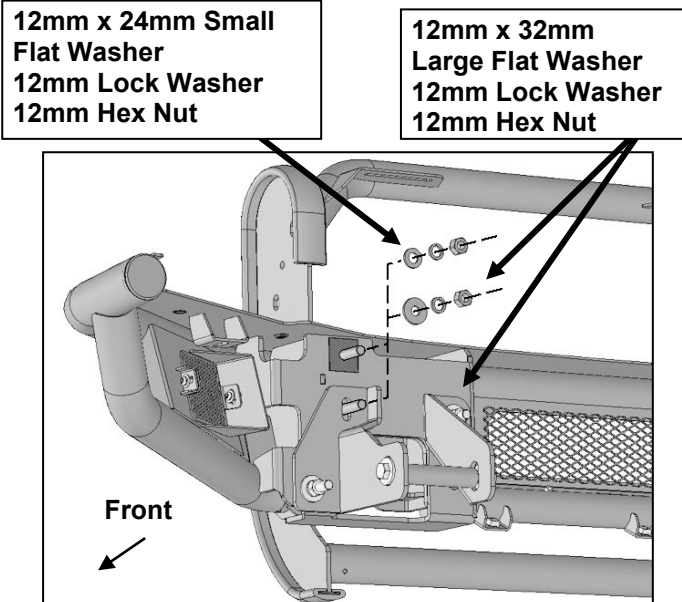

**(Fig 6) Reuse the outer Double Bolt Plate to attach the Push Bar to the PB Shackle Bracket (see Figs 2 & 5)**

**Driver/left Side Installation Pictured**



**(Fig 7) Reuse the outer Double Bolt Plate to attach the driver/left side of the Push Bar to the PB Shackle Bracket and Bumper**

- (2) 8mm x 25mm Button Head Bolts**
- (2) 8mm x 16mm Small Flat Washers (outer)**
- (2) 8mm x 24mm STD Flat Washers (inner)**
- (2) 8mm Lock Washers**
- (2) 8mm Hex Nuts**



**(Fig 8) Push Bar installed (without U-Covers). Note lights pictured not included**

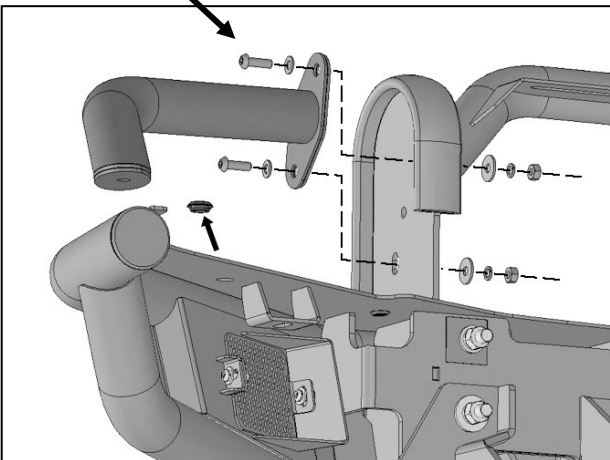

**(Fig 9) Remove the Rubber Plug. Attach the driver/left Override to the Push Bar upright**

**8mm x 25mm Combo Hex Bolt**

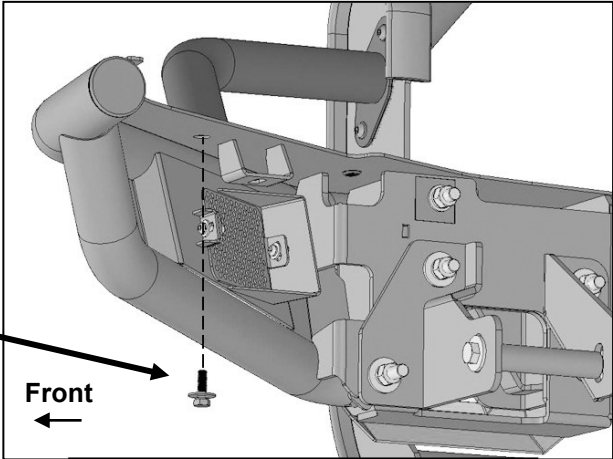

**(Fig 10) Attach the driver/left Override to the top of the Bumper**

**Driver/left Side Installation Pictured**

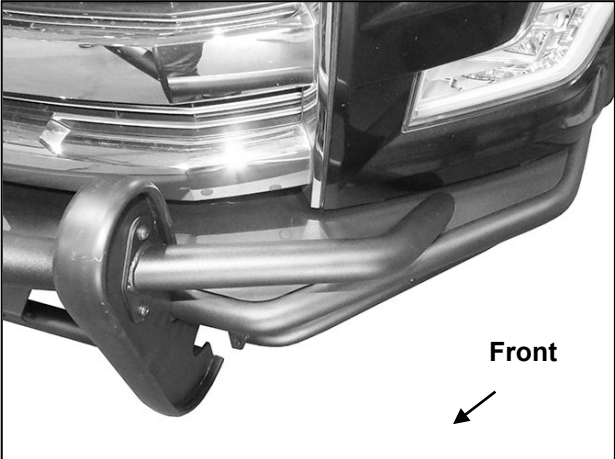

**(Fig 11) Driver/left Override installed**

- 8mm x 16mm Hex Bolt
- 8mm Lock Washer
- 8mm x 24mm STD Flat Washer

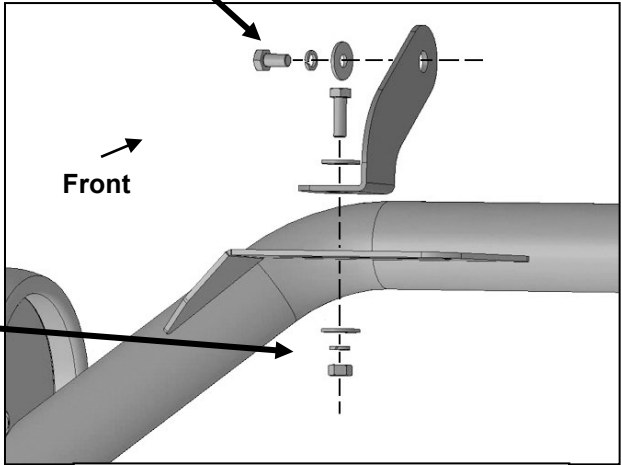

**(Fig 12) Attach driver/left "L" Bracket to tab on back of Push Bar**

- 8mm x 25mm Hex Bolt
- (2) 8mm x 24mm STD Flat Washers
- 8mm Lock Washer
- 8mm Hex Nut

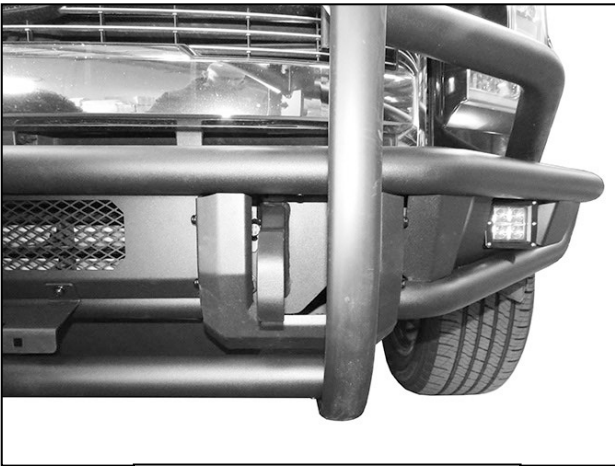

**(Fig 13) Reinstall U-Covers**