

PARTS LIST:

1	HD4 LD Front Bumper	2	12mm Double Bolt Plates
1	Driver/left Shackle Mount	4	12mm Single Bolt Plates
1	Passenger/right Shackle Mount	8	12mm Plastic Retainers
1	Driver/left Inner Support Bracket	2	12-1.75mm x 150mm Hex Bolts
1	Passenger/right Inner Support Bracket	12	12mm x 32mm x 3mm Large Flat Washers
1	Driver/left Outer Support Bracket	2	12mm x 24mm x 2.5mm STD Flat Washers
1	Passenger/right Outer Support Bracket	12	12mm Lock Washers
2	Frame Tube Spacers	12	12mm Hex Nuts
2	U-Cover Plates	14	6-1.0mm x 20mm Combo Bolts
1	Driver/left Outer Mesh Panel	4	6mm Flange Nuts
1	Passenger/right Outer Mesh Panel	1	5mm Wrench
1	License Plate Bracket	1	4mm Wrench
2	Plastic Plugs for license plate mount	10	Nylon Wire Ties

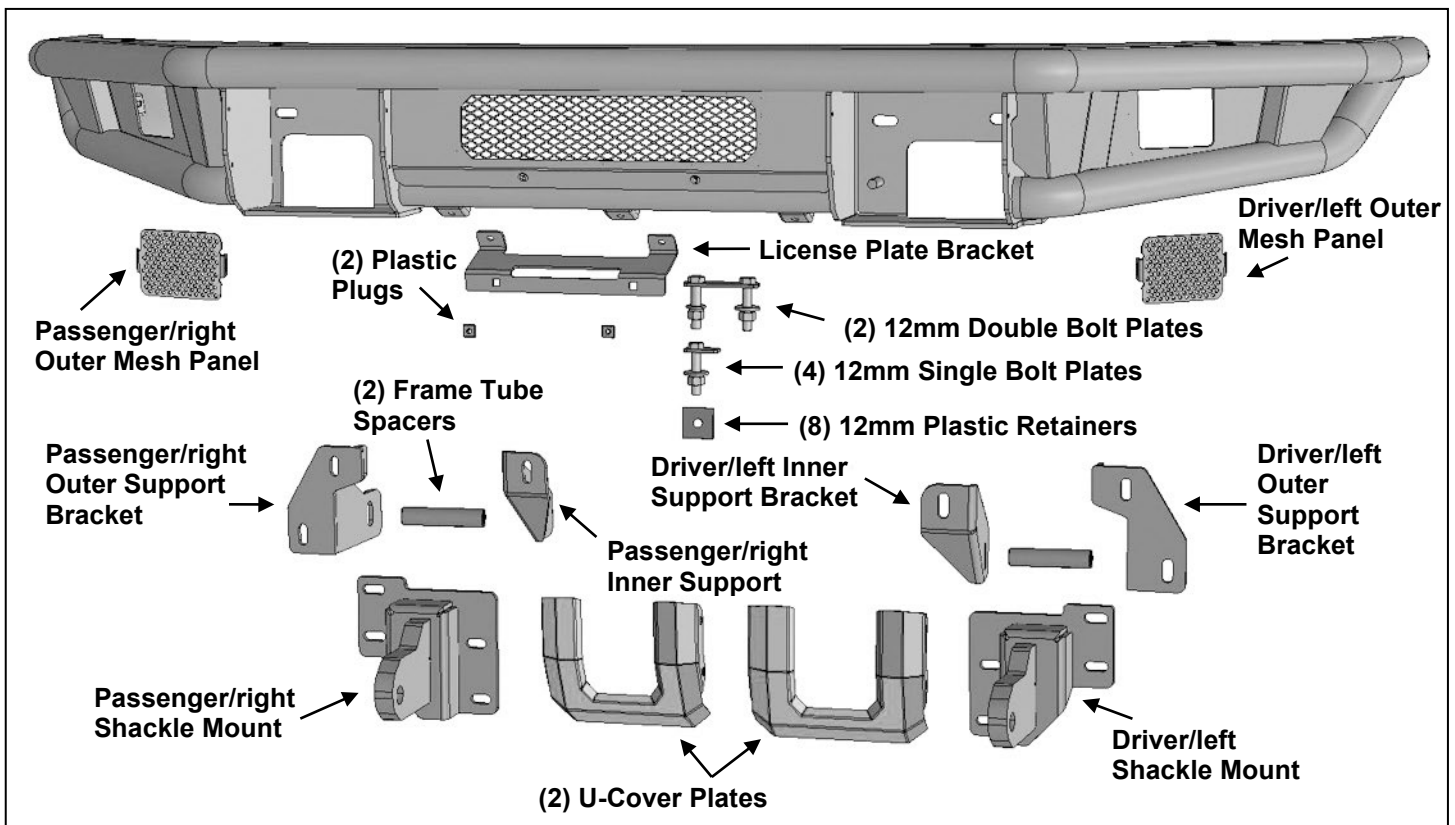

PROCEDURE:

REMOVE CONTENTS FROM BOX. VERIFY ALL PARTS ARE PRESENT. READ INSTRUCTIONS CAREFULLY BEFORE STARTING INSTALLATION. ASSISTANCE IS RECOMMENDED TO AVOID POSSIBLE INJURY OR DAMAGE TO THE VEHICLE.

1. Remove the license plate and bracket, **(Figure 1)**. Remove the plastic bumper pad assembly, **(Figure 2)**. **NOTE:** Carefully pull bumper pad straight out away from bumper. Unplug and remove the adaptive cruise control, if equipped, **(Figure 3)**.
2. Unplug the fog lights, if equipped, **(Figure 4)**. Release the wiring harness from the clips attached to the back of the bumper. Move all wiring harnesses away from bumper.
3. Place blocks or jack stands under the front bumper to support it during mounting bolt removal. Once the bumper has been safely supported, remove the large hex nut, (1 per side), from the back of the bumper bracket attaching the lower bumper to the bumper bracket, **(Figure 5)**. Next, from the front of the bumper, remove the (2) factory hex nuts (per side) attaching the bumper to the bumper brackets,

(Figure 6). WARNING! Assistance is required to hold the bumper in place during hardware removal to prevent the bumper from falling.

4. Remove the bolt plates from the bumper brackets on the frame, **(Figure 7)**. **NOTE:** Use a flat blade screwdriver to pry off the lock washers holding the bolt plates in place. **OPTIONAL-** On models with bolt on frame extensions, remove the extensions from outside of frame, **(Figure 8)**. **NOTE:** On some models the factory bolts may need to be cut to remove frame extensions.
5. Select (1) Tube Spacer, **(Figures 9 & 10)**. Insert the Spacer into and through the holes in the side of the frame.
6. Select the driver/left inner and outer Support Brackets, **(Figure 10)**. Attach the Support Brackets to the inner and outer sides of the frame with the included (1) 12mm x 150mm Hex Bolt, (2) 12mm x 32mm Large Flat Washers, (1) 12mm Lock Washer and (1) 12mm Hex Nut, **(Figures 11 & 12)**. **NOTE:** Insert the Hex Bolt through the Outer Support Bracket, the Tube Spacer and then through the Inner Support Bracket. Hold the mounting plates up against the bumper bracket on the frame, line up the holes and snug but do not fully tighten the hardware at this time.
7. Repeat **Steps 5 & 6** to install the passenger/right inner and outer Support Brackets.
8. Unwrap the Bumper assembly. Determine if accessory lights, (not included), or Screen Fill Panels will be installed at this time. It is easier to install lights or Fill Panels before attaching Bumper to vehicle.
Outer Screen Fill Panel Installation (do not install fill panels if installing lights).
 - a. Attach the driver/left Screen Fill Panel to the tabs on the back of the Bumper with the included (2) 6mm Button Head Combo Bolts and (2) 6mm Flange Nuts, **(Figure 13)**. Fully tighten Fill Panel hardware at this time. Repeat this **Step** to install the remaining passenger/right Fill Panel.**Outer LED cube style light installation, (lights not included).**
 - a. Attach lights to the mounting tabs at the outer ends of the Bumper, **(Figure 14)**.
 - b. Follow the light manufacturer's instruction to properly wire lights once Bumper is installed.
9. Select the driver/left Shackle Mount Bracket, **(Figure 15)**. Attach the Bracket to the threaded stud on the Bumper mount with the included (1) 12mm x 32mm Large Flat Washer, (1) 12mm Lock Washer and (1) 12mm Hex Nut, **(Figure 16)**. Leave hardware loose. Select (1) Single Bolt Plate and (1) Plastic Retainer. Insert the Bolt Plate into the inner mounting hole above the threaded stud, **(Figure 16)**. Thread the Plastic Retainer onto the threaded end of the Bolt Plate to help hold it in place in the Bumper, **(Figure 18)**. Next select (1) Double Bolt Plate. Insert the Bolt Plate through the outer holes in the Shackle Mount Bracket, **(Figure 17)**. Secure the Double Bolt Plate to the top hole only in the Bracket with the included (1) 12mm x 24mm Small Flat Washer, (1) 12mm Lock Washer and (1) 12mm Hex Nut, **(Figure 18)**. Leave hardware loose.
10. Repeat **Step 9** to attach the passenger/right side Shackle Mount Bracket to the Bumper.
11. With assistance, position the Bumper Assembly up to the frame. Temporarily support the weight of the Bumper. **WARNING:** To avoid possible injury or damage to the vehicle, do not proceed until the bumper is fully and safely supported.
12. Guide the threaded ends of the Double and Single Bolt Plates through the holes in the bumper mounts on the frame and through the Support Brackets, **(Figure 19)**. Attach the Bumper and Bolt Plates to the frame and Support Brackets with the included (4) 12mm x 32mm Large Flat Washers, (4) 12mm Lock Washers and (4) 12mm Hex Nuts. Leave hardware loose at this time.
13. Select (1) 12mm Single Bolt Plate. From the front, insert the Bolt Plate through the bottom-outer mounting hole in the driver/left side of the Bumper and through the Outer Support Bracket, **(Figure 20)**. Secure the Support Bracket to the Single Bolt Plate with the included (1) 12mm x 32mm Large Flat Washer, (1) 12mm Lock Washer and (1) 12mm Hex Nut, **(Figure 21 & 22)**. Leave hardware loose at this time. Repeat this **Step** to attach the passenger/right Outer Support Bracket to the Single Bolt Plate.
14. Level and adjust the Bumper to the vehicle and fully tighten all hardware, **(Figure 23)**.
15. Select (1) U-Cover Plate, **(Figure 24)**. Attach the Cover to the threaded holes in the front of the Bumper with the included (4) 6mm Combo Bolts. Repeat this Step to attach the remaining U-Cover to the passenger/right side of the Bumper, **(Figure 25)**.
16. Attach the License Plate Bracket to the holes in the bumper with the included (2) 6mm x 20mm Button Head Combo Bolts, **(Figure 26)**. Insert (2) Plastic Plugs into the square holes in the Bracket. Reuse the factory screws to attach the license plate.
17. Do periodic inspections to the installation to make sure that all hardware is secure and tight.

To protect your investment, Do not use any type of polish or wax that may contain abrasives that could damage the finish. Mild soap may be used to clean the Bumper assembly.

Driver/left Side Installation Pictured



(Fig 1) Remove license plate from Bumper



Front



(Fig 2) Remove the plastic bumper pad from the front of the Bumper

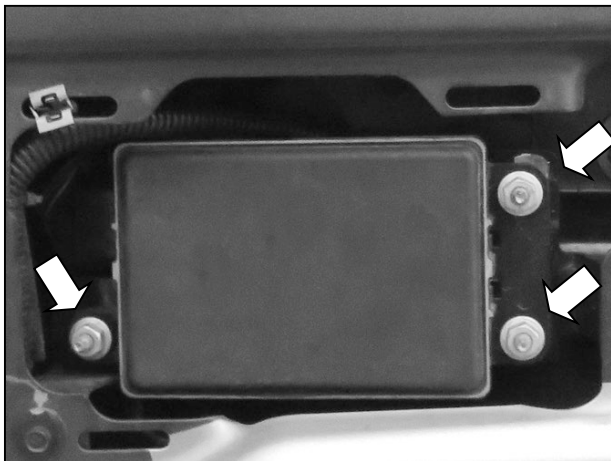

(Fig 3) Remove and unplug adaptive cruise control from driver/left side of frame, if equipped

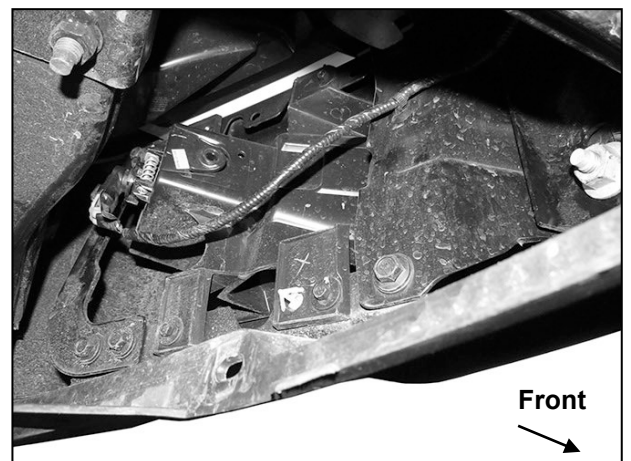

Front



(Fig 4) Unplug and move factory wiring harness for fog lights (if equipped)

Driver/left Side Installation Pictured

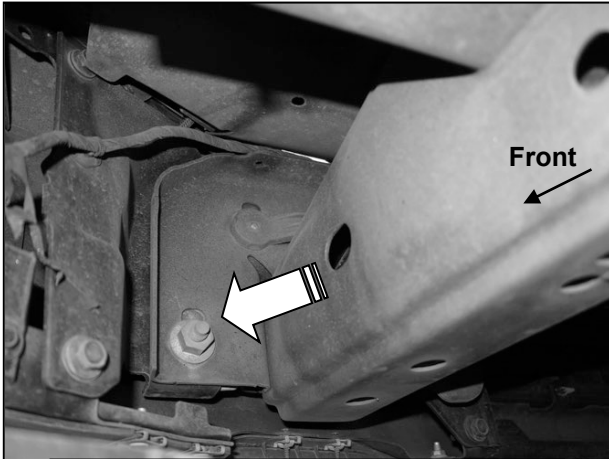

(Fig 5) Remove factory hex nut (arrow) from back of bumper bracket

WARNING! Do not remove bumper bolts unless the bumper is properly supported on blocks or stands or it may fall.

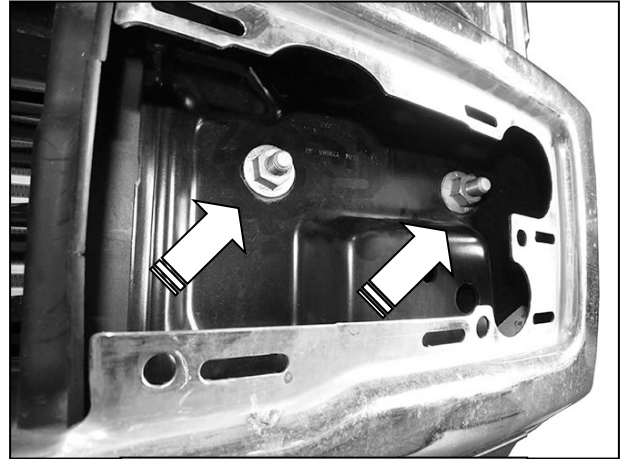

(Fig 6) Remove the (2) factory hex nuts from each side

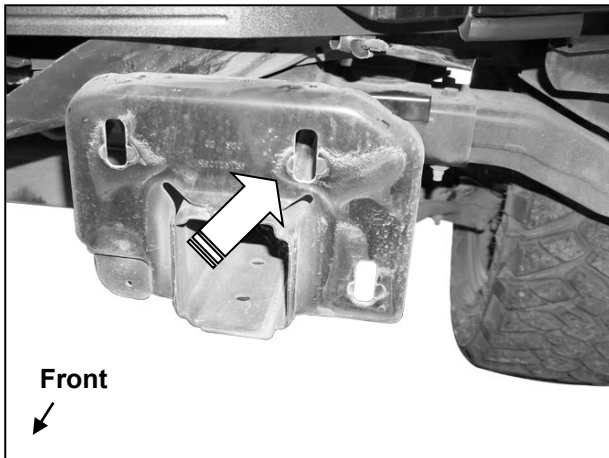

(Fig 7) Remove double bolt plates from end of frame (driver/left side end of frame pictured)



(Fig 8) Optional, remove the factory frame extensions, if equipped

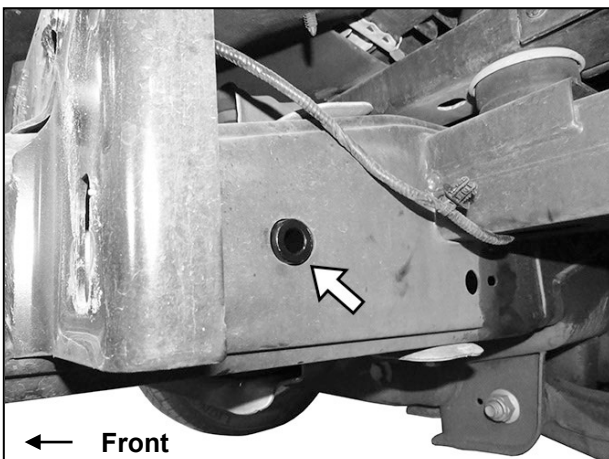

(Fig 9) Insert the Frame Tube Spacers into the holes in the frame. Driver/left side pictured

Driver/left Side Installation Pictured

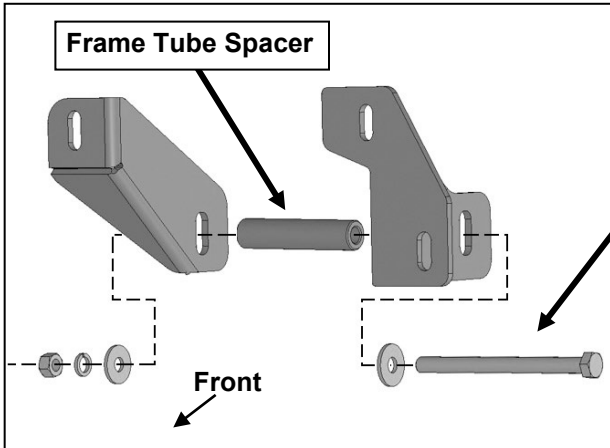

12mm x 150mm Hex Bolt
(2) 12mm x 32mm Large Flat Washers
12mm Lock Washer
12mm Hex Nut

(Fig 10) Attach the driver/left Inner and Outer Support Brackets to the sides of the frame

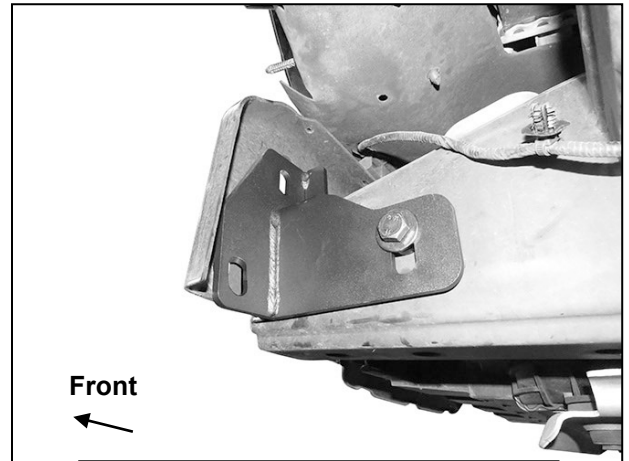

(Fig 11) Attach driver/left Outer Support Bracket to outside of frame

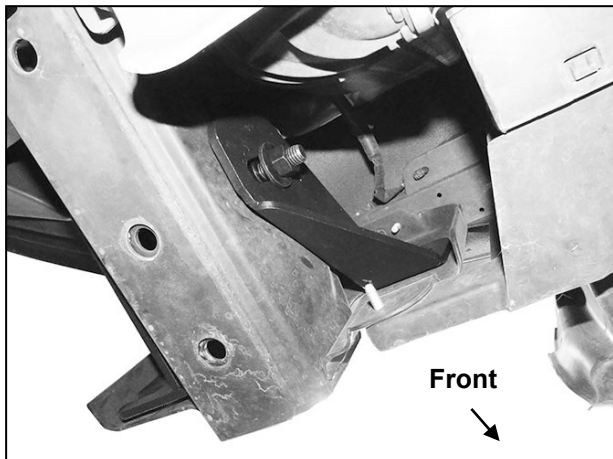

(Fig 12) Attach driver/left Inner Support Bracket to inner side of frame

(2) 6mm Combo Bolts
(2) 6mm Flange Nuts

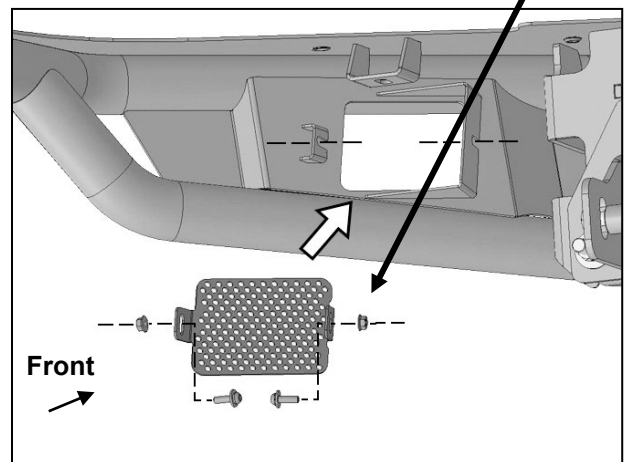

(Fig 13) Attach the Outer Mesh Panels to the tabs on the back of the Bumper

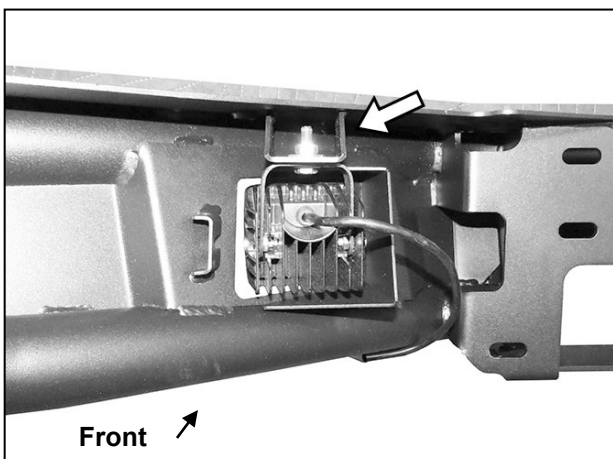

(Fig 14) Attach the cube light (not included) to the tab on the back of the Bumper

Driver/left Side Installation Pictured

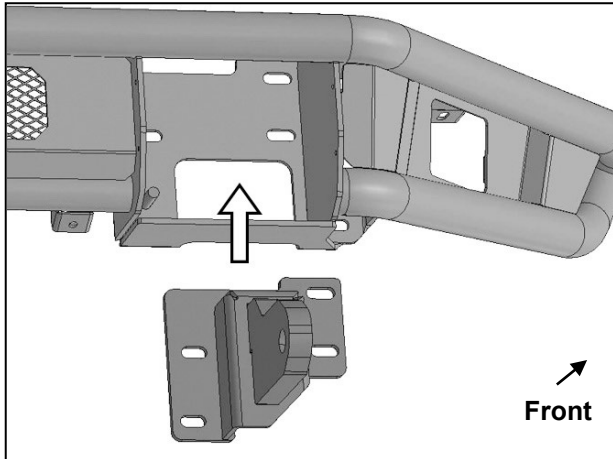

(Fig 15) Insert driver/left Shackle Mount into pocket in Bumper

12mm Single Bolt Plate

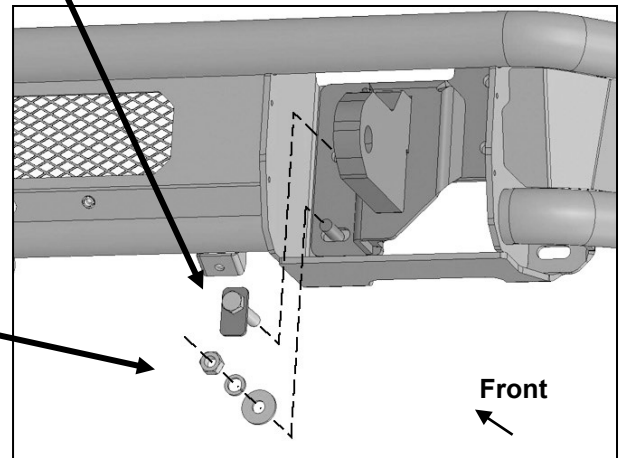

(Fig 16) Attach Shackle Mount to threaded stud on Bumper. Insert Single Bolt Plate through top inner mounting slot

12mm x 32mm Large Flat Washer
12mm Lock Washer
12mm Hex Nut

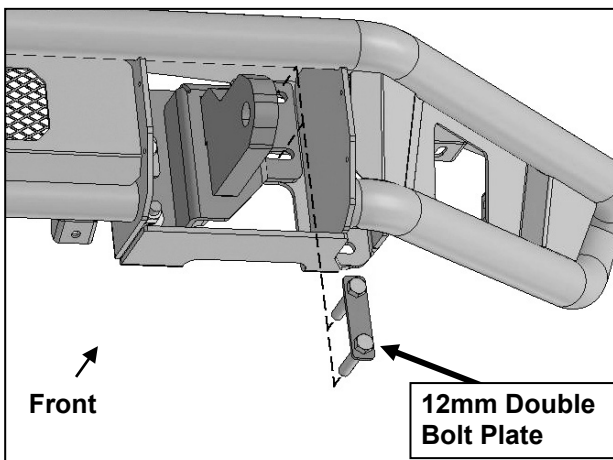

12mm Double Bolt Plate

(Fig 17) Insert 12mm Double Bolt Plate into outer slots in Shackle Mount and Bumper

12mm x 24mm Small Flat Washer
12mm Lock Washer
12mm Hex Nut

12mm Plastic Retainers

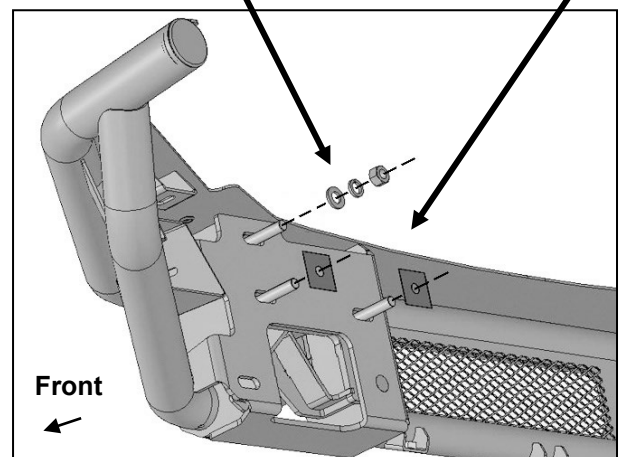

(Fig 18) Use top threaded bolt on Double Bolt Plate to attach Shackle Mount to Bumper. Thread Plastic Retainers onto Bolt Plates to hold them in place for Bumper installation

Driver/left Side Installation Pictured

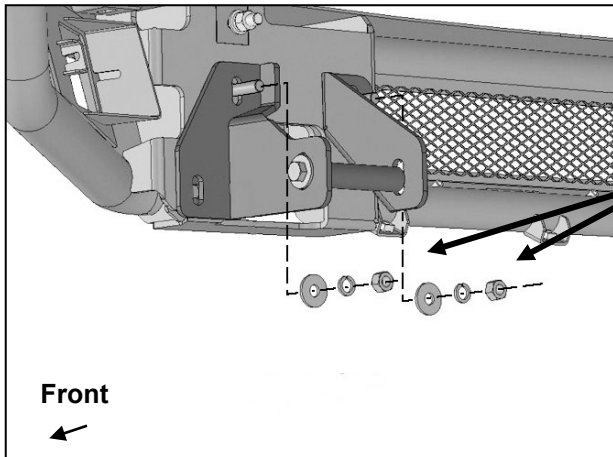

12mm x 32mm Large Flat Washer
12mm Lock Washer
12mm Hex Nut

12mm Single Bolt Plate

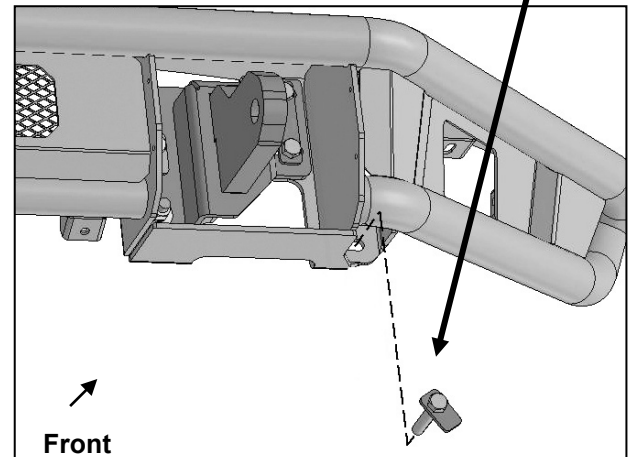

(Fig 20) Insert Single Bolt Plate through outer slot in Bumper and Support Bracket

(Fig 19) Hold Bumper up to end of frame. Guide Bolt Plates in Bumper through bumper bracket on frame and Support Brackets

12mm x 32mm Large Flat Washer
12mm Lock Washer
12mm Hex Nut

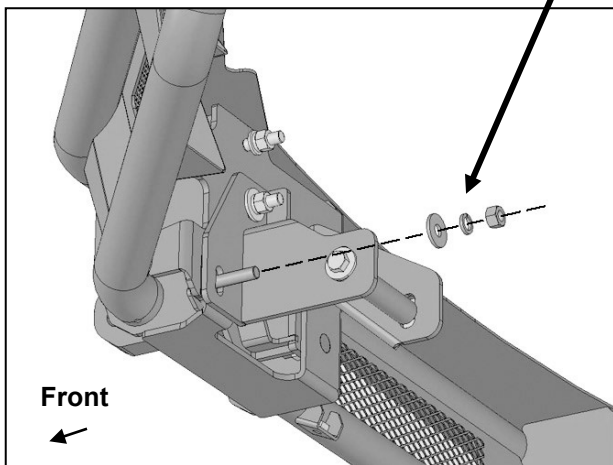

(Fig 21) Attach Bumper to Single Bolt Plate, frame and Support Bracket

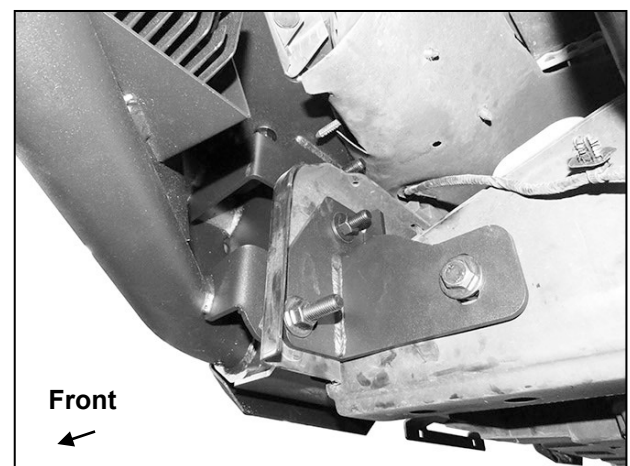

(Fig 22) Driver/left side of Bumper installed. Pictured from behind Bumper

Driver/left Side Installation Pictured

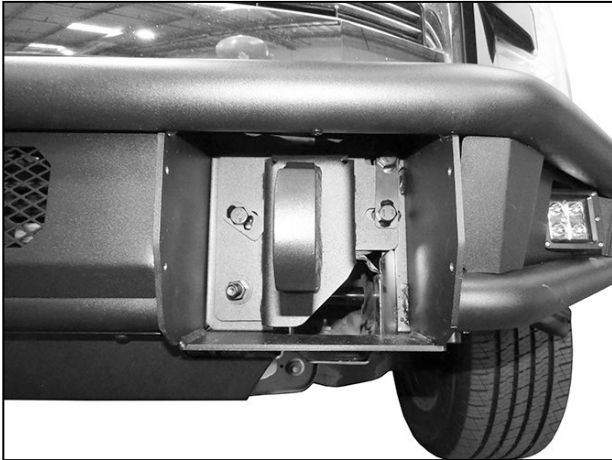

**(Fig 23) Driver/left side of Bumper installed
(cube light pictured not included)**

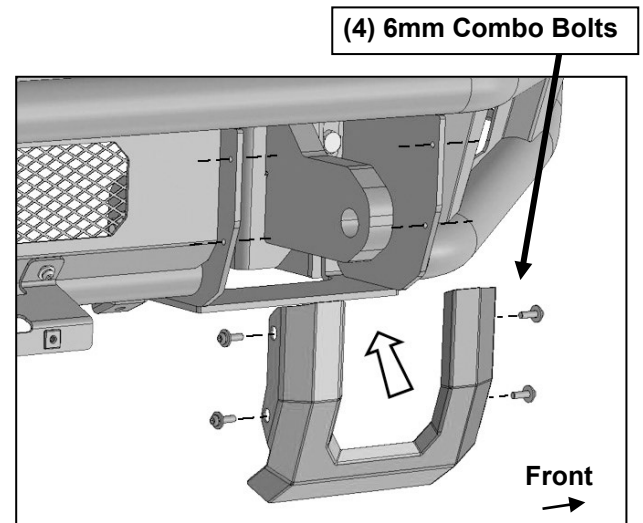

(Fig 24) Once Bumper is fully installed and hardware fully tightened, install U-Covers

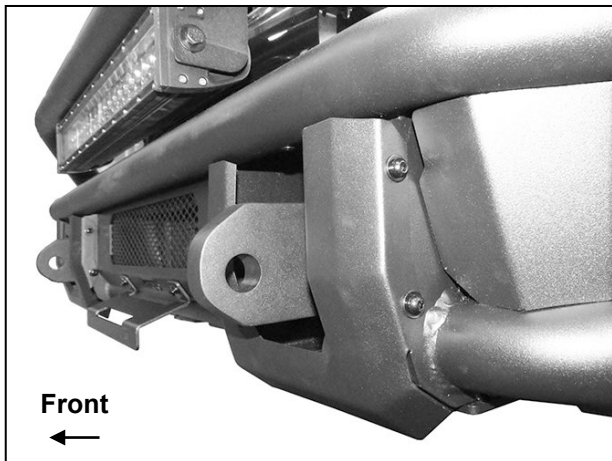

**(Fig 25) Driver/left U-Cover installed
(light not included)**

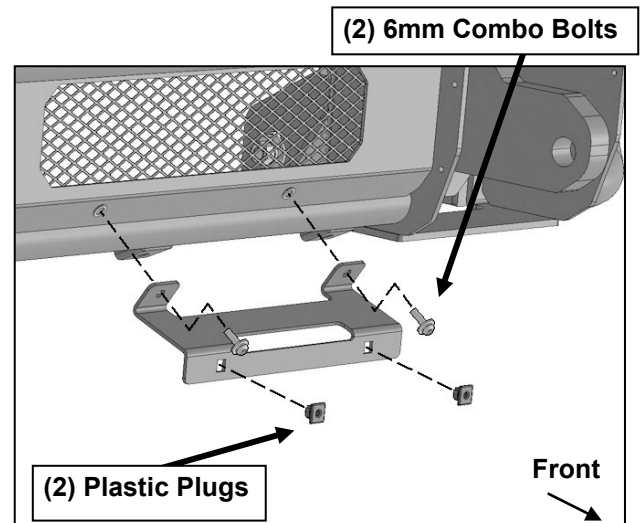

(Fig 26) Attach License Plate Bracket to front of Bumper

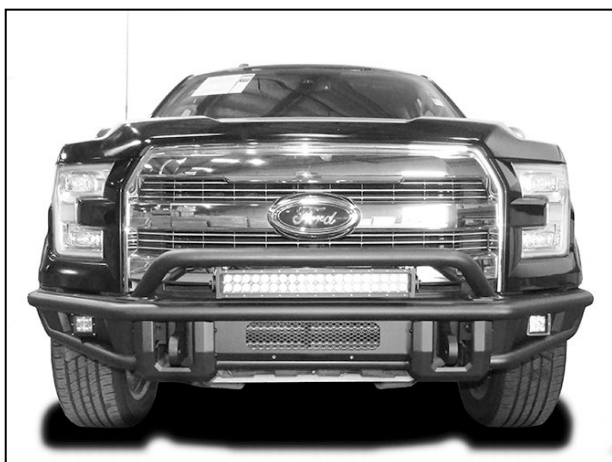

Complete Installation (lights and hoop not included)