

**PARTS LIST:**

1	HD4 HD Push Bar	2	8-1.25mm x 25mm Combo Bolts
1	Driver/left Override Tube	4	8-1.25mm x 25mm Button Head Bolts
1	Passenger/right Override Tube	2	8-1.25mm x 25mm Hex Bolts
1	Driver/left "L" Light Bracket	2	8-1.25mm x 16mm Hex Bolts
1	Passenger/right "L" Light Bracket	10	8mm x 24mm x 2mm STD Flat Washers
2	12mm x 32mm x 3mm Large Flat Washers	4	8mm x 16mm x 1.6mm Small Flat Washers
2	12mm x 24mm x 2.5mm Small Flat Washers	8	8mm Lock Washers
4	12mm Lock Washers	6	8mm Hex Nuts
4	12mm Hex Nuts	1	5mm Wrench

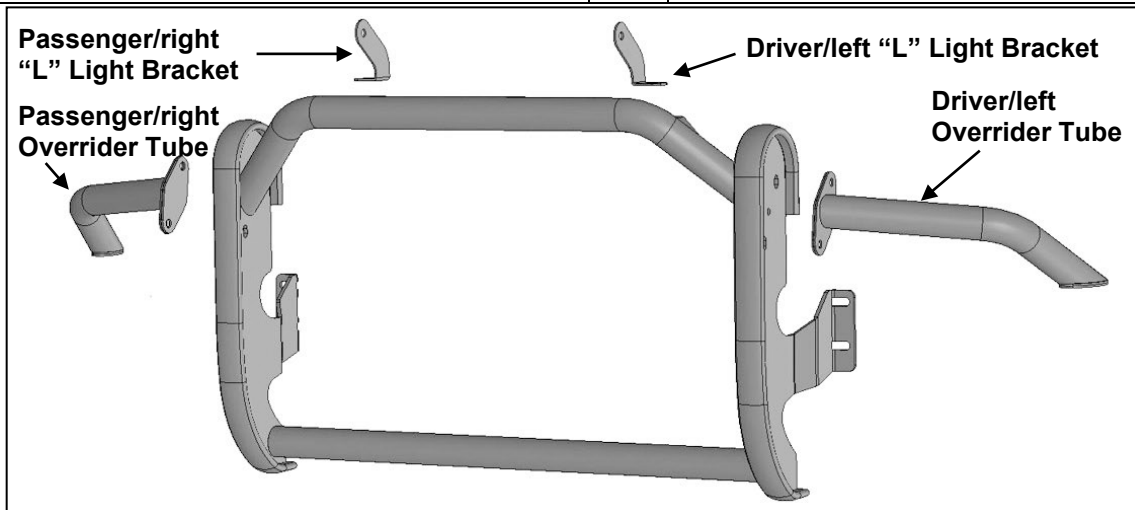

**PROCEDURE:**

**REMOVE CONTENTS FROM BOX. VERIFY ALL PARTS ARE PRESENT. READ INSTRUCTIONS CAREFULLY BEFORE STARTING INSTALLATION. ASSISTANCE IS RECOMMENDED TO AVOID POSSIBLE INJURY OR DAMAGE TO THE VEHICLE.**

1. Follow the instructions to install and align the HD4 LD Bumper to the vehicle.
2. Remove the driver/left U-Cover, **(Figure 1)**. Temporarily remove the outer Double Bolt Plate, **(Figures 2 & 3)**. Repeat this **Step** to remove the passenger/right U-Cover and Bolt Plate.
3. With assistance, position the Push Bar Assembly up to the outer slots in the Bumper and Winch Tray, **(Figure 4)**. Reinstall (1) 12mm Double Bolt Plate into the driver/left side of the Push Bar but replace the hardware with the included (1) 12mm x 24mm Small Flat Washer (top), (1) 12mm x 32mm Large Flat Washer, (bottom), (2) 12mm Lock Washers and (2) 12mm Hex Nuts, **(Figures 5 & 6)**. Repeat this **Step** to attach the passenger/right side of the Push Bar.
4. Level and adjust the Push Bar to the vehicle and fully tighten all hardware.
5. Select the driver/left Override Tube, **(Figure 7)**. Remove the Rubber Plug from the top of the Bumper. Attach the flange on the Override Tube to the upright on the Push Bar with the included (2) 8mm x 25mm Button Head Bolts, (2) 8mm x 16mm Small Flat Washers (outside), (2) 8mm x 24mm STD Flat Washers (inside), (2) 8mm Lock Washers and (2) 8mm Hex Nuts, **(Figure 7)**. Attach the end of the Override Tube to the top of the Bumper with the included (1) 8mm x 25mm Combo Hex Bolt, **(Figures 8 & 9)**. Repeat this **Step** to install the passenger/right Override Tube.
6. Determine if accessory light, (not included), will be installed at this time. **NOTE:** Push Bar assembly is designed to be compatible with most Bar Style LED lights with a maximum of 8mm or 5/16" mounting hardware. Modifying the Push Bar assembly for hardware larger than 8mm (5/16") will damage the finish and is not recommended.  
**LED bar style light installation (light not included).**

- a. Measure mounting slot width on Push Bar before purchasing light to verify fitment.
  - b. Select the driver/left "L" Light Bar Bracket, **(Figure 10)**. **NOTE:** "L" Brackets are offset to adjust for different widths of LED Bar Lights and can be installed on either side and above or below as needed.
  - c. Attach the "L" Bracket to the slot on the back of the Bull Nose assembly with (1) 8mm x 25mm Hex Bolt, (2) 8mm Flat Washers, (1) 8mm Lock Washer and (1) 8mm Hex Nut, **(Figure 10)**. Repeat this **Step** to install the remaining "L" Bracket. **IMPORTANT:** The Bull Nose assembly features slots designed for top or hanging light installation.
  - d. Attach the light to the "L" Brackets with the included (2) 8mm x 16mm Hex Bolts, (2) 8mm Lock Washers and (2) 8mm Flat Washers or use the hardware included with the light, **(Figure 10)**. Do not fully tighten hardware at this time.
7. Reinstall the U-Cover Plates, **(Figure 11)**.
  8. Do periodic inspections to the installation to make sure that all hardware is secure and tight.

**To protect your investment,** Do not use any type of polish or wax that may contain abrasives that could damage the finish. Mild soap may be used to clean the Bumper and Push Bar assembly.

### Driver/left Side Installation Pictured

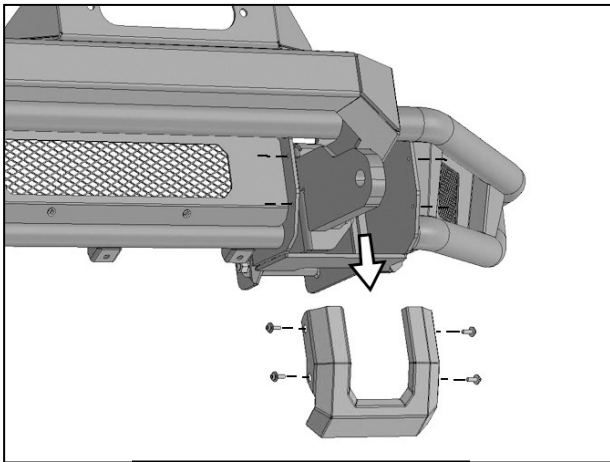

**(Fig 1) Remove U-Cover**

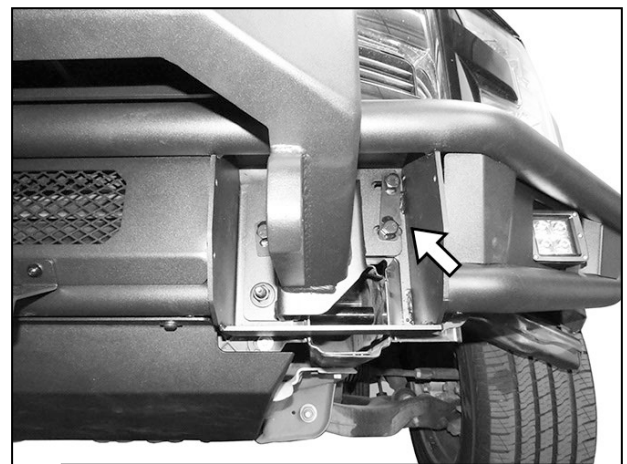

**(Fig 2) Remove Outer Double Bolt Plate**

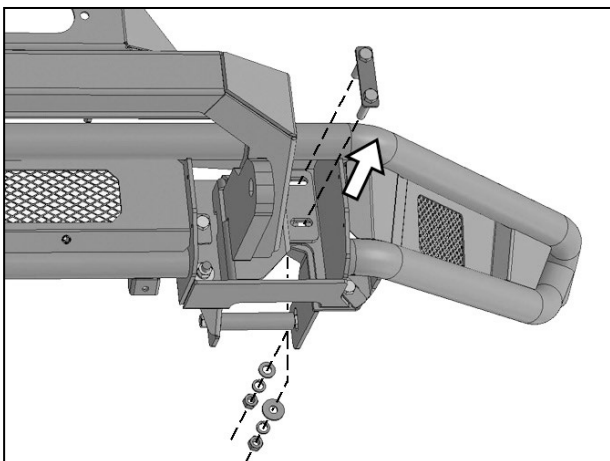

**(Fig 3) Remove Outer Double Bolt Plate**

### Driver/left Side Installation Pictured

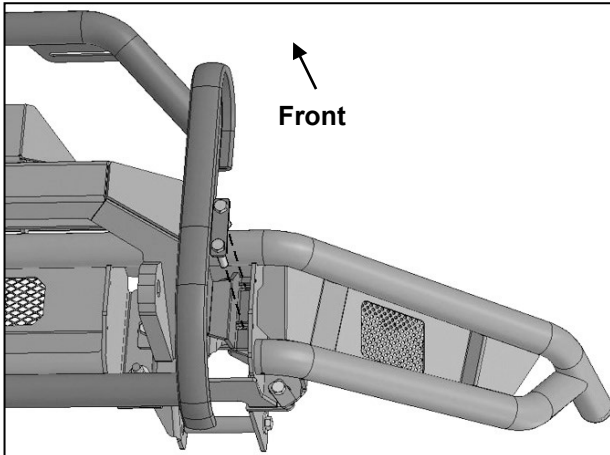

(Fig 4) Reuse the outer Double Bolt Plate to attach the Push Bar to the PB Shackle

- 12mm x 24mm Small Flat Washer (top)
- 12mm Lock Washer
- 12mm Hex Nut

- 12mm x 32mm Large Flat Washer (bottom)
- 12mm Lock Washer
- 12mm Hex Nut

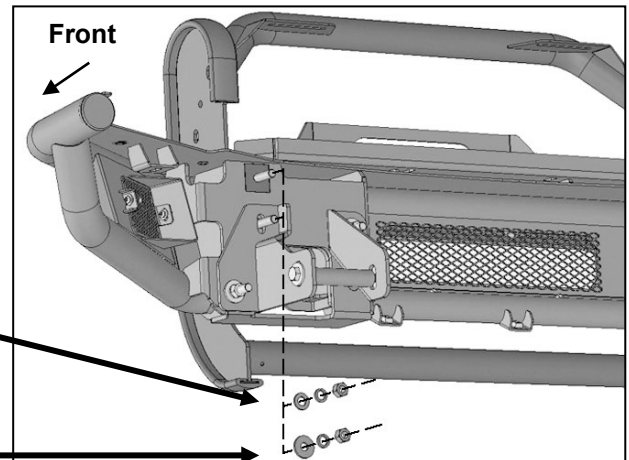

(Fig 5) Attach the outer Double Bolt Plate and Push Bar to the PB Shackle Bracket (also see Figures 2 & 5).

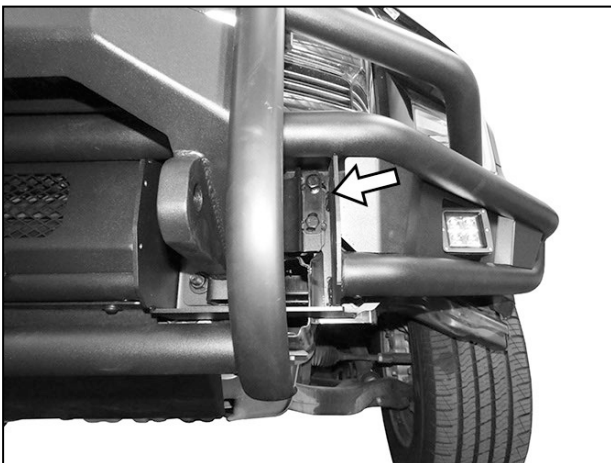

(Fig 6) Reuse the outer Double Bolt Plate to attach the driver/left side of the Push Bar to the PB Shackle Bracket and Bumper

- (2) 8mm x 25mm Button Head Bolts
- (2) 8mm x 16mm Small Flat Washers (outer)
- (2) 8mm x 24mm STD Flat Washers (inner)
- (2) 8mm Lock Washers
- (2) 8mm Hex Nuts

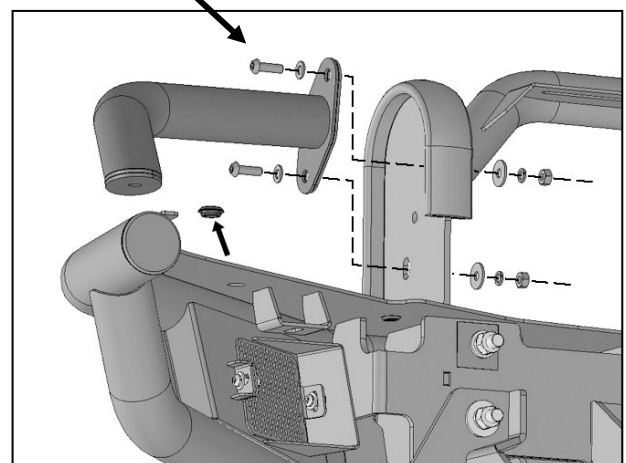

(Fig 7) Remove the Rubber Plug. Attach the driver/left Override to the Push Bar upright

### Driver/left Side Installation Pictured

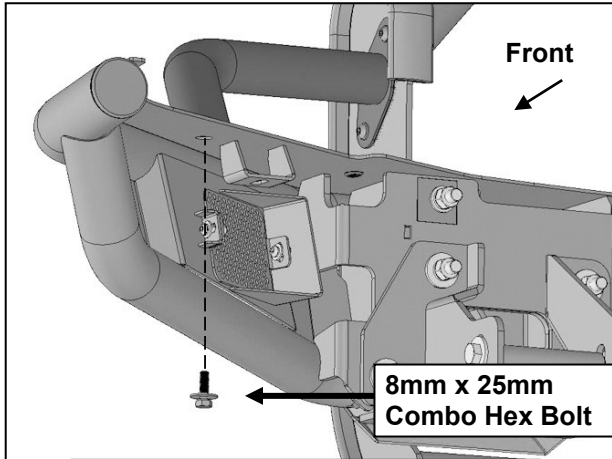

(Fig 8) Attach the driver/left Overrider to the top of the Bumper

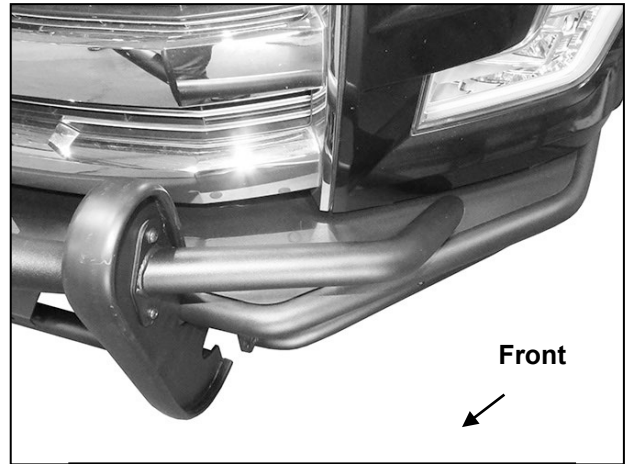

(Fig 9) Driver/left Overrider installed

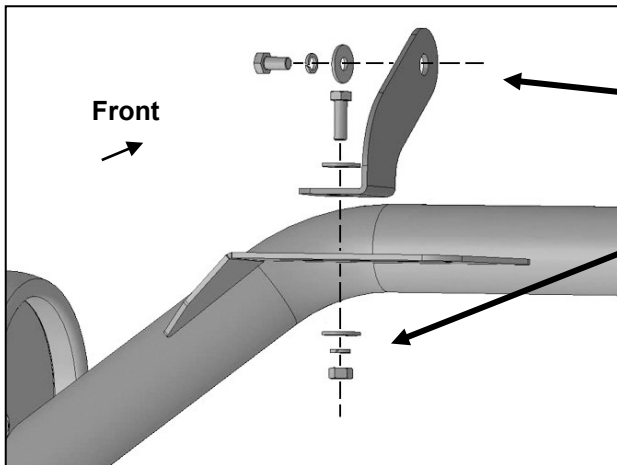

8mm x 16mm Hex Bolt  
8mm Lock Washer  
8mm x 24mm STD Flat Washer

8mm x 25mm Hex Bolt  
(2) 8mm x 24mm STD Flat Washers  
8mm Lock Washer  
8mm Hex Nut

(Fig 10) Attach driver/left "L" Bracket to tab on back of Push Bar

