

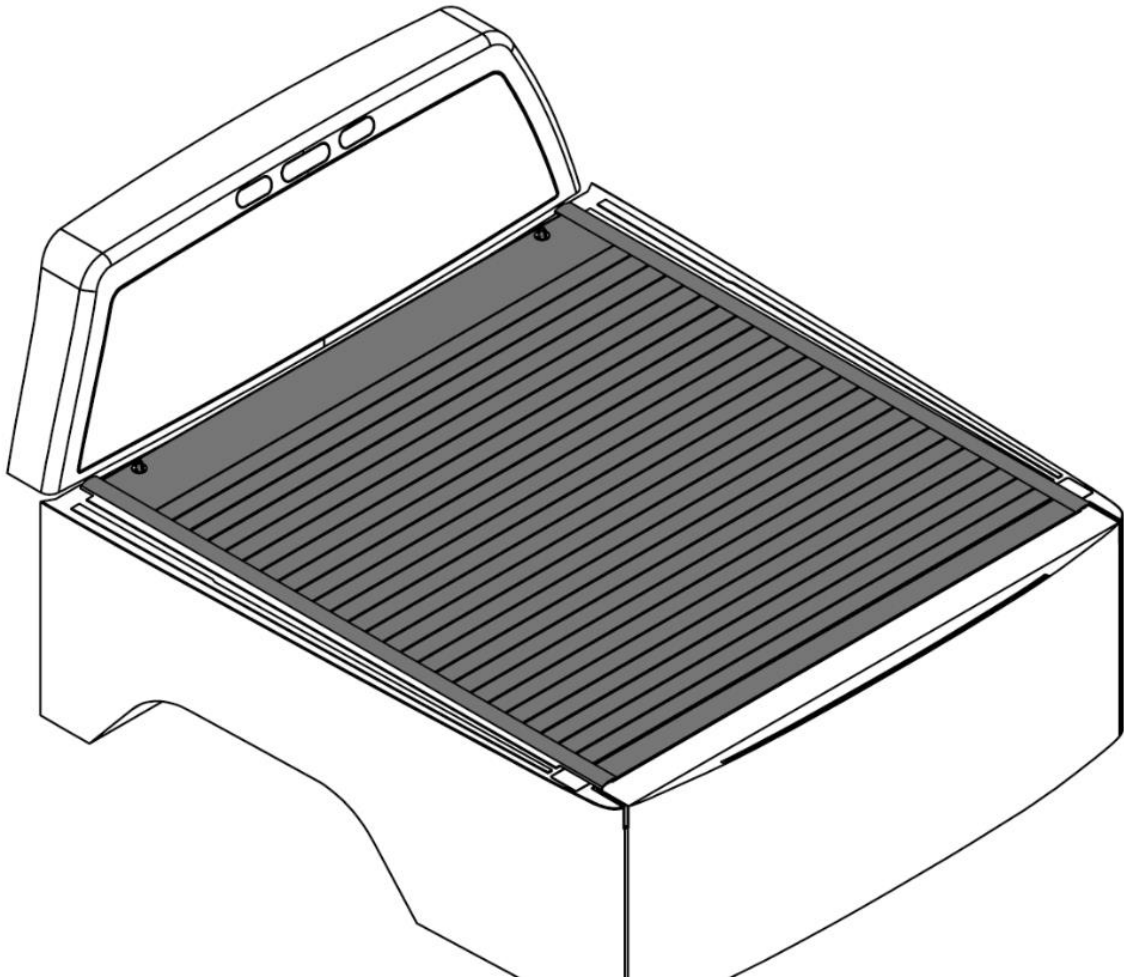



TRUSHIELD



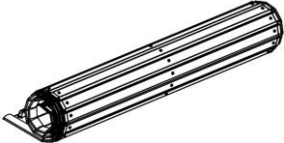

INSTALLATION MANUAL

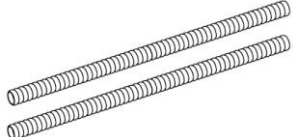
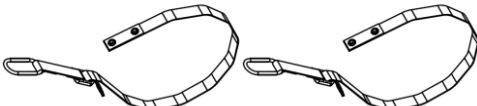
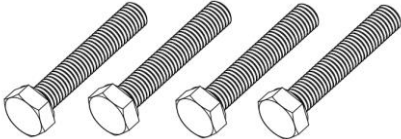
Light Weight Aluminum Hard Roll Up Tonneau Cover

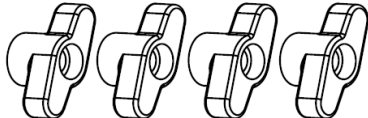
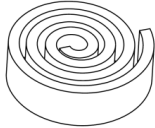

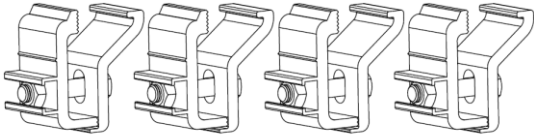
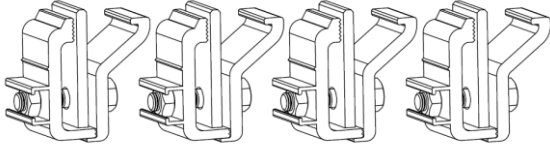
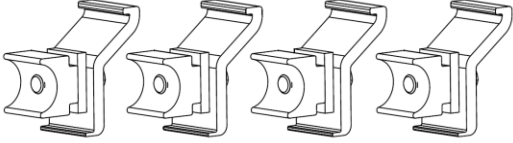
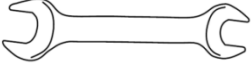
Parts included in the carton

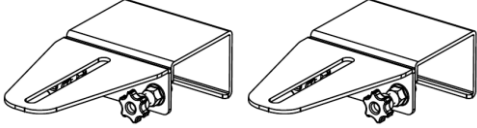
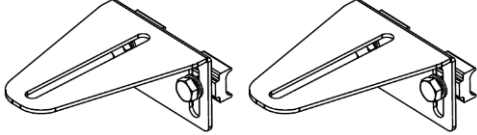
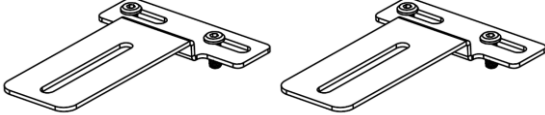
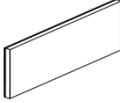
Item	Description	Qty	Picture
F1	Roll up Cover	1	
F2	Left Side Rail	1	
F3	Right Side Rail	1	
F4	Drain Tube	2	
F5	Security Straps	2	
F6	Front Bolt	4	
F7	Flat Washer	4	
F8	Spring Washer	4	
F9	T type Nut	4	
F10	Foam Seal	1	

F11	Clamp A (for truck without Utility Track)	4	
F11R	Clamp for Ranger	4	
F11T	Clamp B (for truck with Utility Track)	4	
F12	14-17mm Spanner	1	
F13	4mm Hex key	1	
F14	Front Bracket A	2	
F14T	Front Bracket B (Fit for Jeep JT & 2022+ Toyota Tundra)	2	
F15	Front Bracket C (Fit for 2024 Ford Ranger)	2	
F16	Rubber pad	2	
F17	Extra replacement Velcro	6	
F18	Installation Manual	1	

STEPS:

1. Check contents of carton with the list above.

2. **Attention: except below models, start with step3!**

For JT & 2022+ Toyota Tundra & 2024 Tacoma, Insert the two aluminum blocks (F14T) into the Front Bed Rail (located on the Front bed wall) first, and fasten the bracket to the Rail with screws. Don't tighten the screws until the bracket (F14T) and roll up cover are installed.

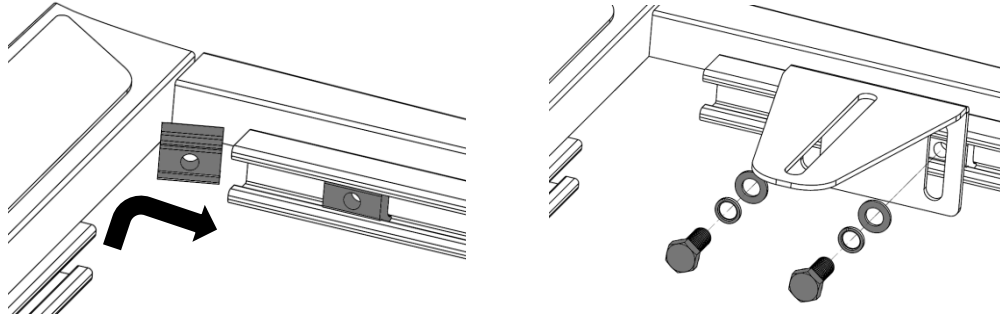

For 2024 Ford Ranger, Attach the bracket (F15) to the threaded hole in the front bulkhead of the truck bed.

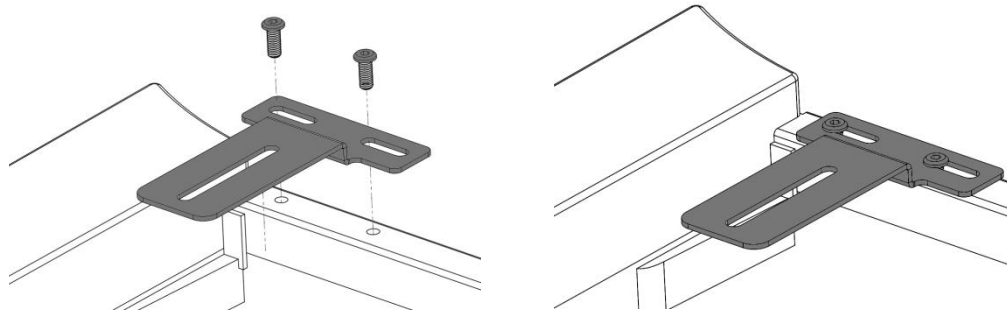

Once the above steps are complete, please ignore step6!

3. Insert the drain tube on the side rail end.

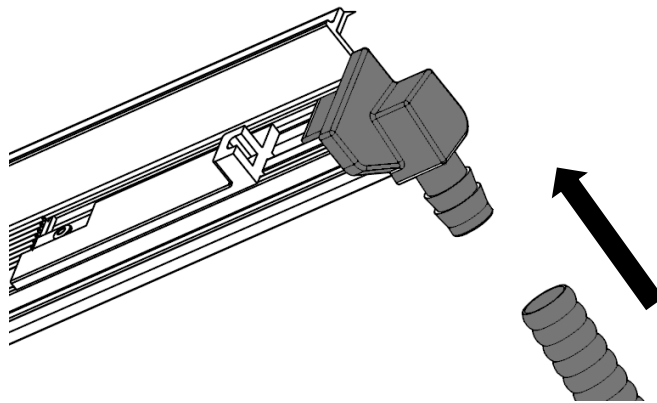

4. Place the side rail (F2/F3) against the bed inside wall, and push it to the front wall of truck bed.

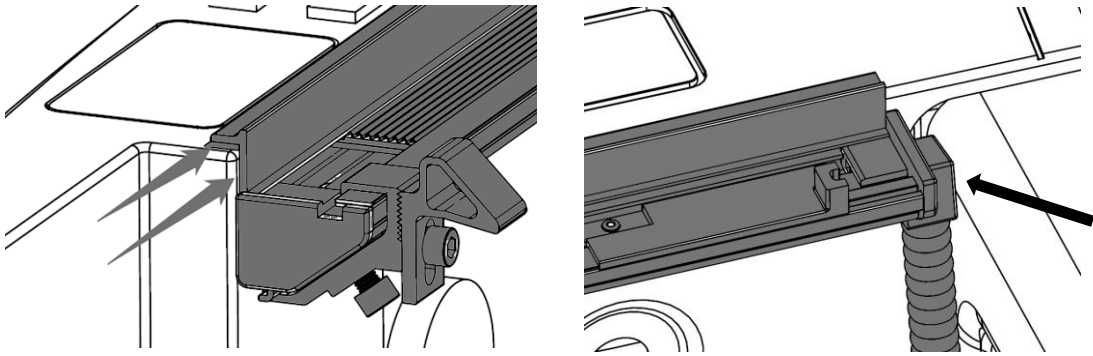

5. Place one clamp A (F11) at the front of the side rail and one at the rear (please make sure the rear clamps is placed on the position that is closest to tailgate). Tighten the clamps each side. Then insert the drain tubes (F4) into the front of bed wall.

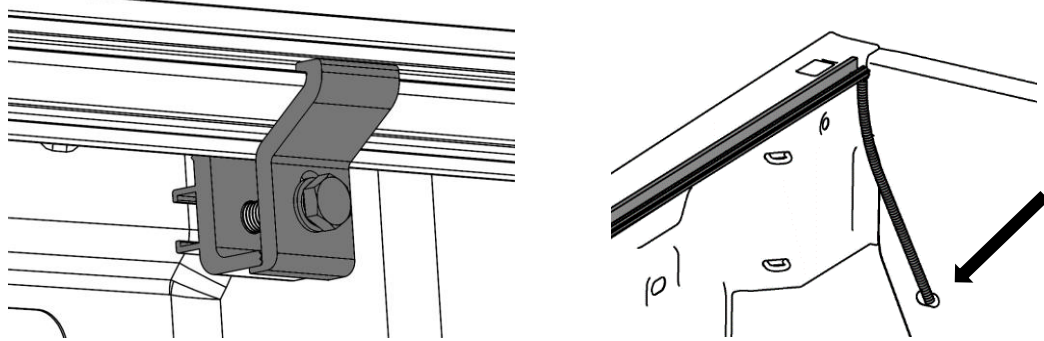

5-1 For Ranger.

- Place one clamp (F11R) at the front of the side rail and one at the rear (please make sure the rear clamps is placed on the position that is closest to tailgate). Tighten the clamps each side. Then insert the drain tubes (F4) into the front of bed wall.

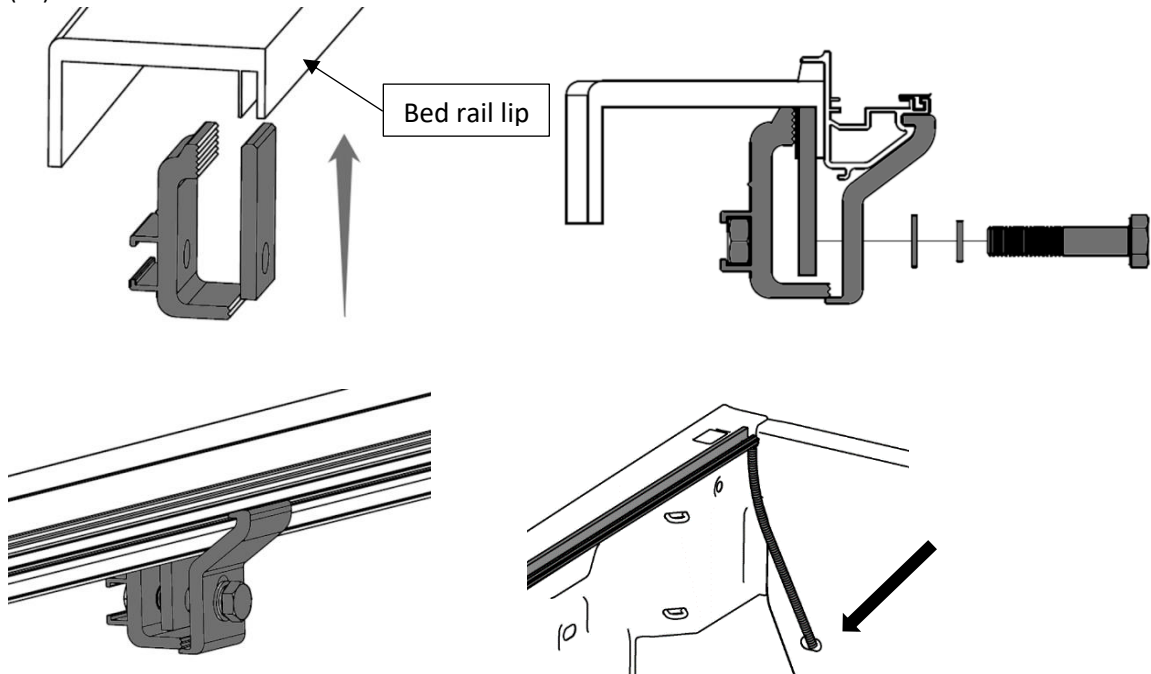

5-2 For Toyota, Nissan Trucks.

Place one clamp A at the front of the side rail and one at the rear (please make sure the rear clamps is placed on the position that is closest to tailgate). Tighten the clamps each side.

5-2-1 For truck without Utility Track system, use Clamp A (F11).

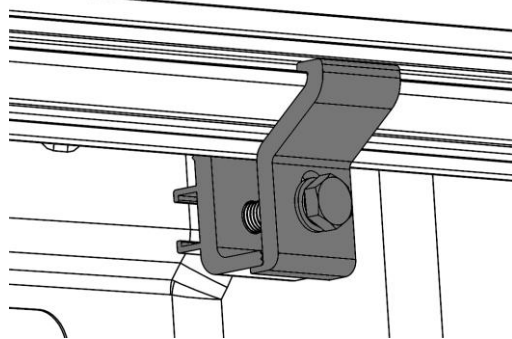

5-2-2 For truck with Utility Track system, use Clamp B (F11T).

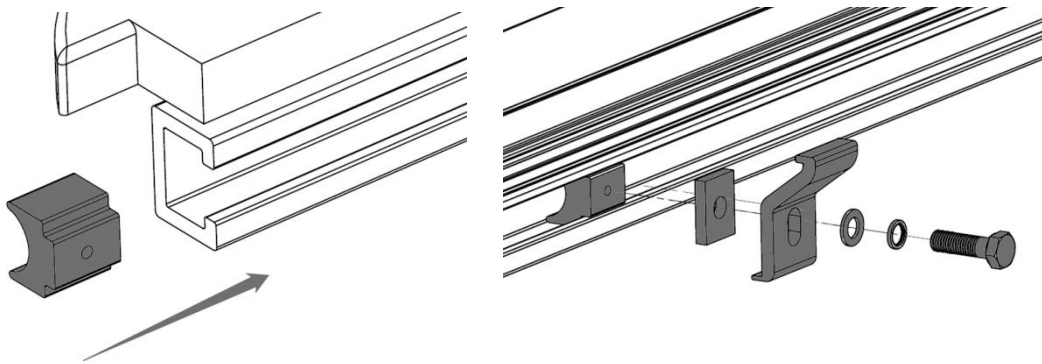

6. Mount the bracket.

6-1 For the front bulkhead of the truck bed is straight.

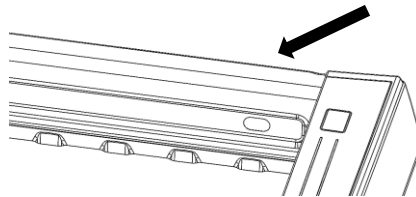

Stick the rubber pad (F16) near the side rail, then put the bracket A (F14) and line it up with the rubber pad, and tighten the bolts.

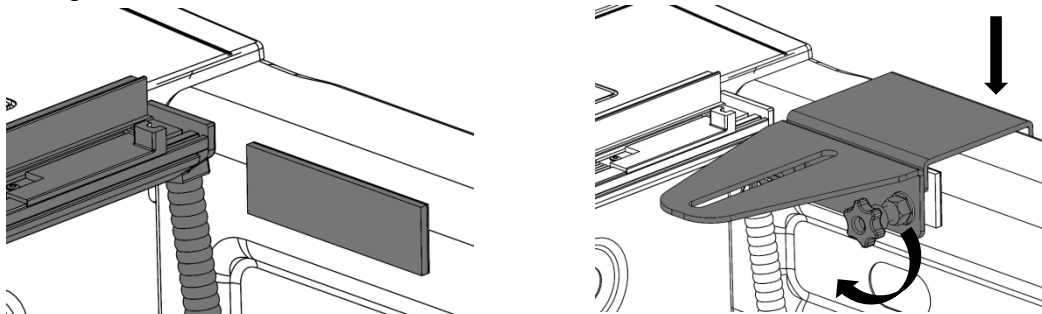

6-2 For the front bulkhead of the truck bed is curvy.

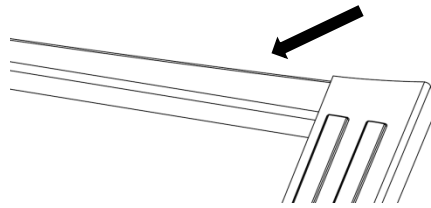

Stick the rubber pad (F16) near the side rail, then put the bracket in the middle of the truck bed, and slide it to line it up with the rubber pad, and tighten the bolts.

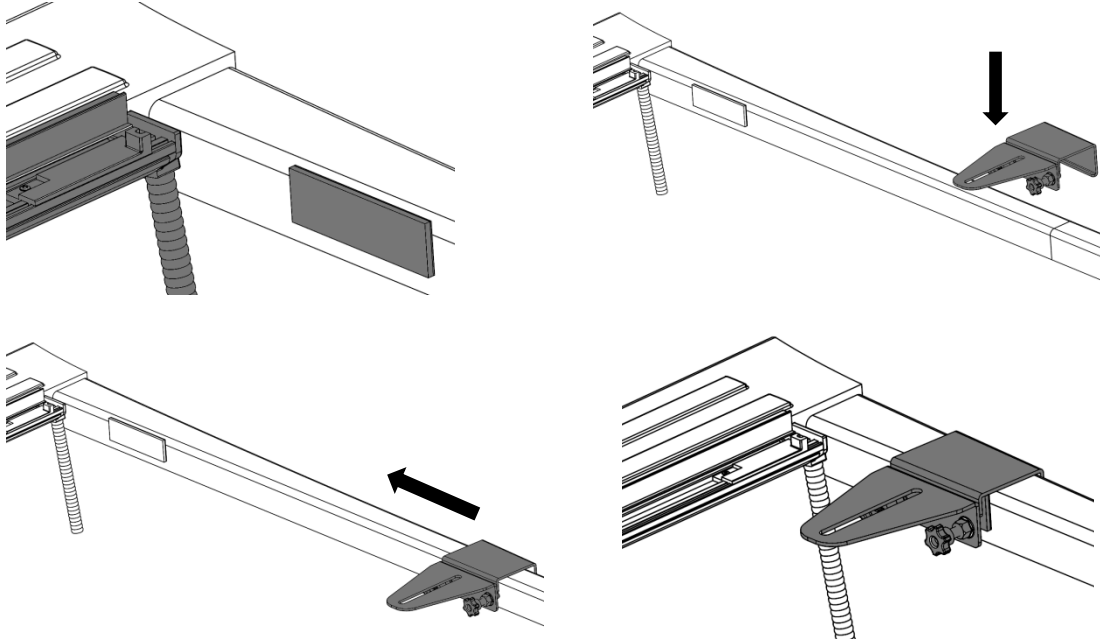

7. Stick the foam seal tape (F10) on the front edge of the bed. The tape length is same as the bed front inner width. Cut off the extra foam.

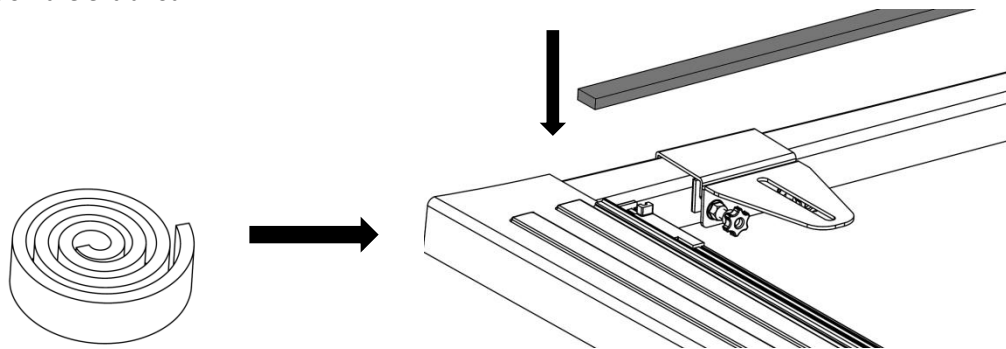

8. Place the hard roll up cover (F1) on the side rails.

* Be attention, The spacing piece on the front of side rail should be aligned with the underneath tab of the cover front panel.

* Be attention, the cover should be placed in the center. The gaps between the cover panel and the 2 side rails should be even.

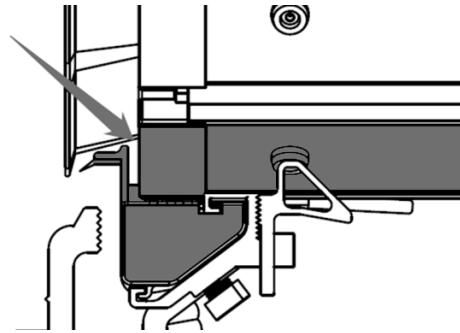
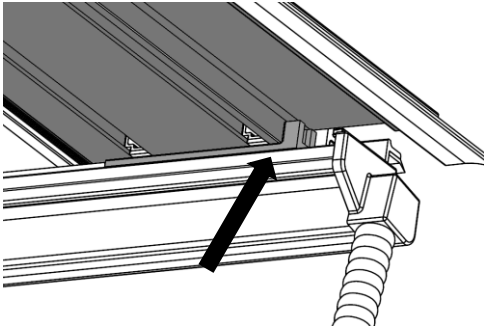

9. Roll up the cover front panel, making the back of front panel facing up. Insert the Front Bolt (F6) into the grooves of the front panel.

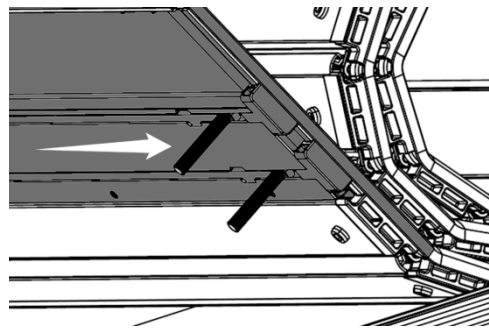
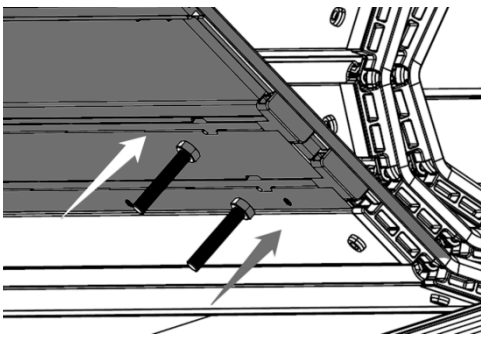

10. Close the cover front panel, and insert the Front Bolts (F6) into the bolt hole of the front bracket.

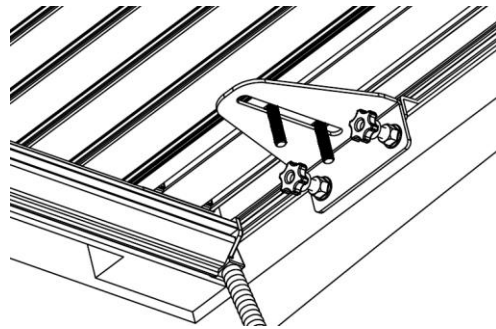
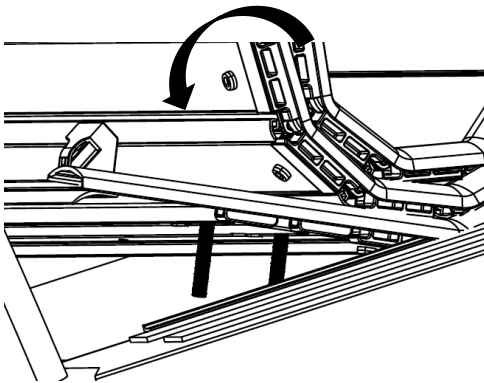

11. Insert the Security Straps (F5) onto the Front Bolt firstly, then insert Flat Washer (F7), Spring Washer (F8), and T Type Nut (F9). Tighten the T type nut firmly.

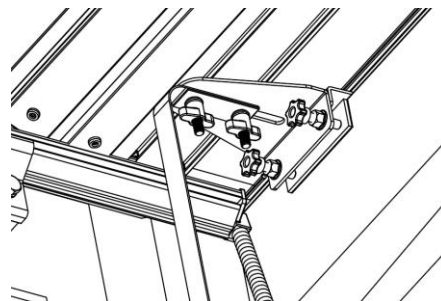
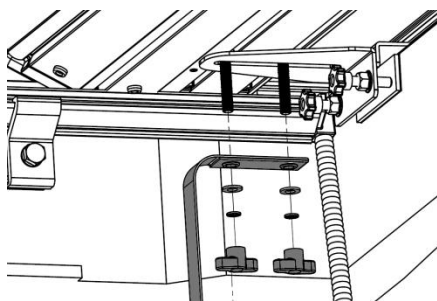

12. Close the cover, adjust the locking base back-and-forth to accommodate the groove of the rear panel. Try to close and open the cover rear panel several times. Make sure the Locking Base does not interfere with the groove of cover rear panel. Then tighten the bolt to fix the locking base on the side rail.

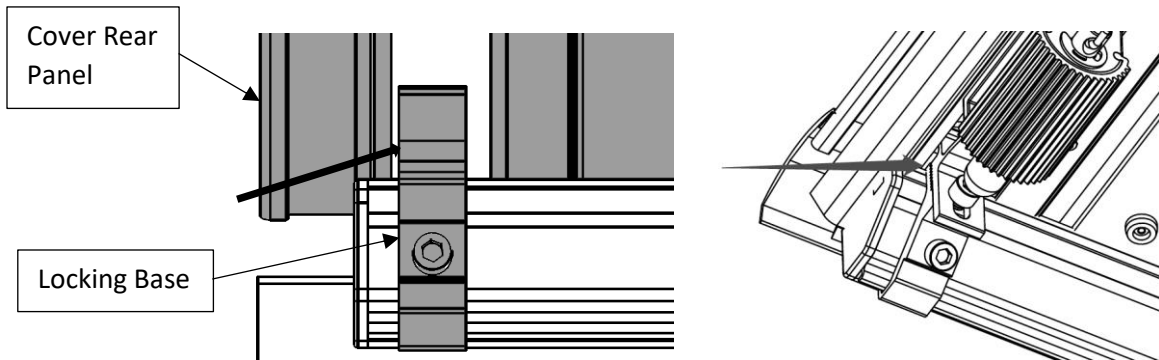

13. If the locking pin on the cover interfere with the locking tongue on the locking base, adjust the locking tongue up and down to a proper position, then tighten the bolt to fix the locking tongue.

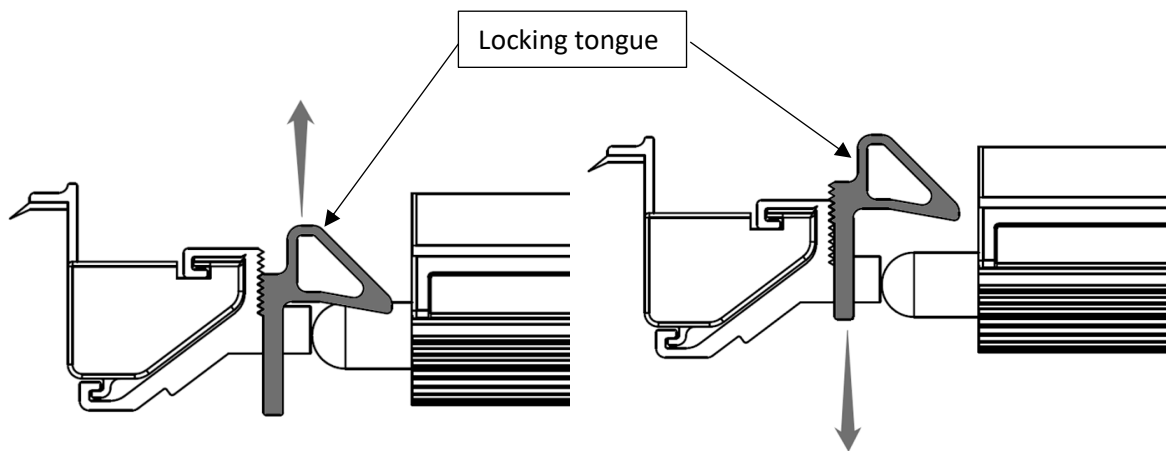

14. After truck tailgate closed, if the tailgate is not touching the cover rear panel rubber seal, there could be some water leaking on the tailgate part. Can adjust the whole cover a little closer to tailgate, by moving the side rail (F2/F3) a little back toward tailgate (loosen the side rail clamps to move, then tighten).

