

Installation Instructions

PARTS LIST:

Qty	Item Description	Qty	Item Description
1	Winch Tray	2	8mm Lock Washer
1	Fairlead plate	6	8mm Flat Washer
2	8-1.25mm x 25mm Button Head Bolt	2	8mm Hex Nuts
1	Allen Wrench S=5	4	8x24x2 Flat Washer
2	15.5mm x 25mm x 2mm Foam Washer	4	Flat Head Self Tapping Screw
2	20mm x 10mm Foam Washer	2	Plastic Plug (Without sensors) (PP)
2	Retaining Cap (PP)		

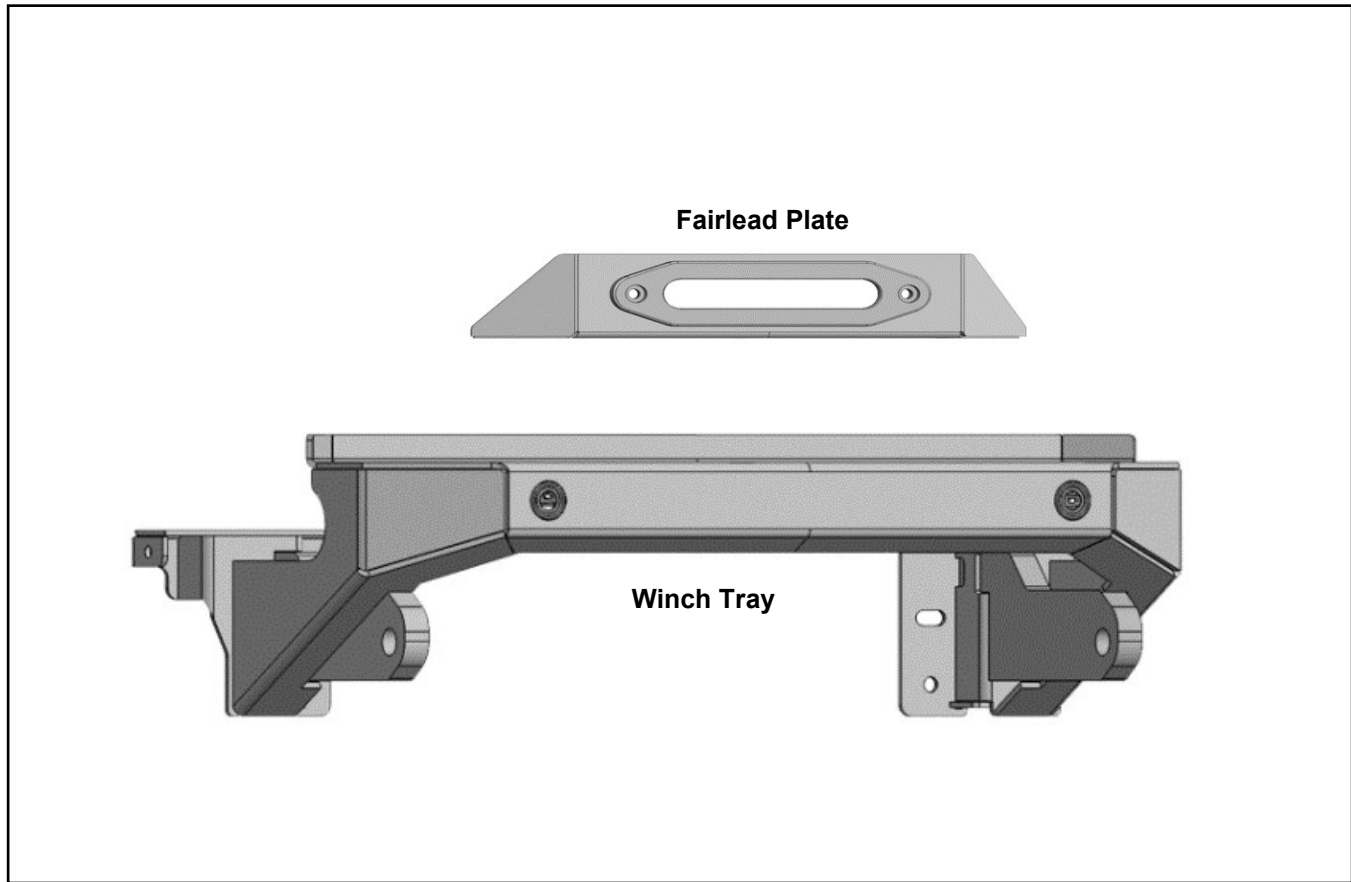

TOOLS REQUIRED



Ratchet



13 & 19mm Socket



Extensions



Wrench

1

Follow (Fig 1 – 5) to remove factory bumper and wiring harness to prepare vehicle for HD Bumper installation.

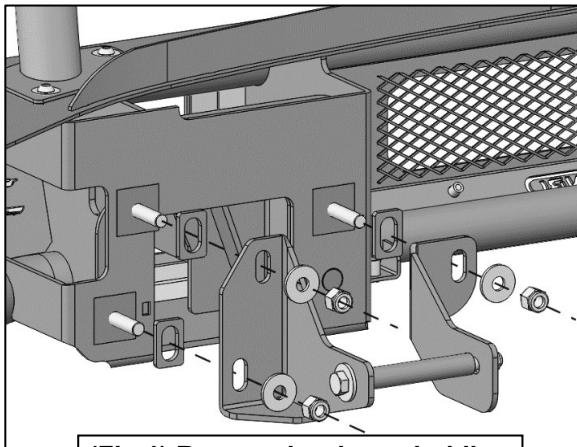

(Fig 1) Remove hardware holding Bumper to mounting brackets

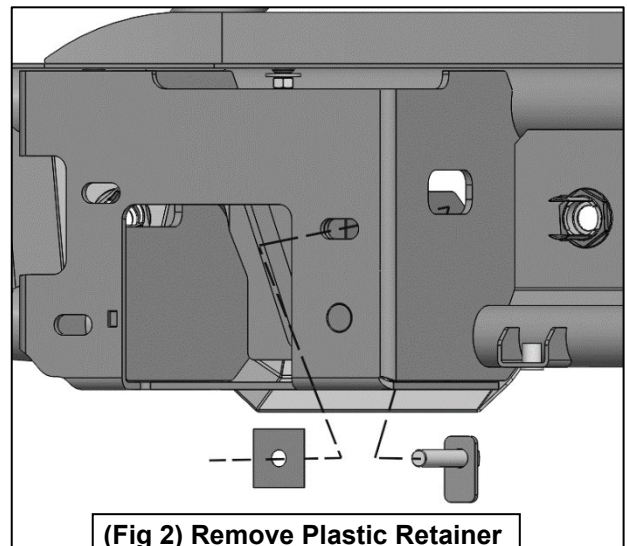

(Fig 2) Remove Plastic Retainer from Single Bolt Plate

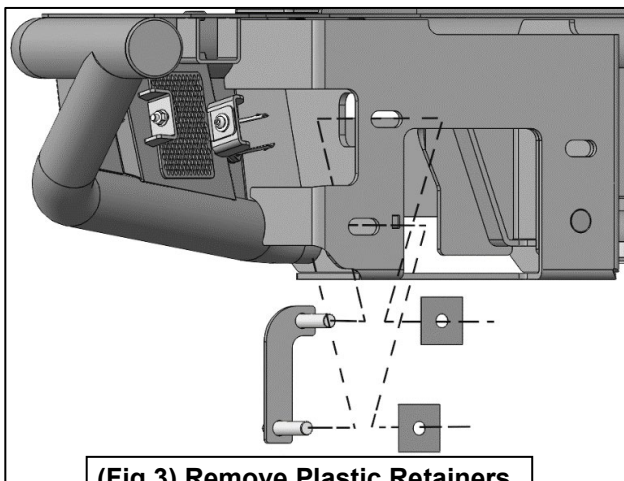

(Fig 3) Remove Plastic Retainers from Double Bolt Plate

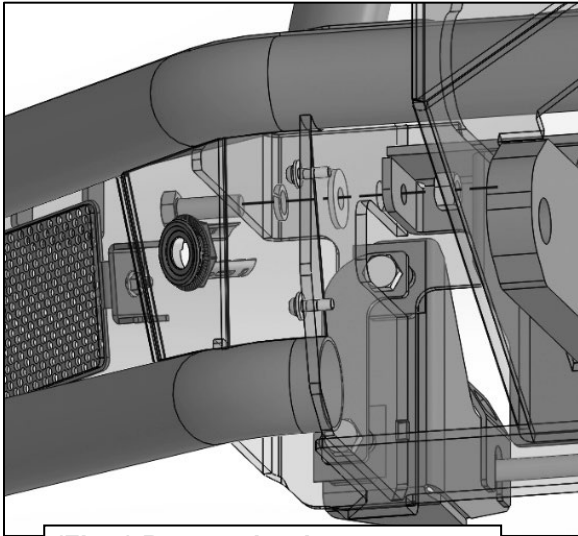

(Fig 4) Remove hardware on rear side of Standard Shackle Mount

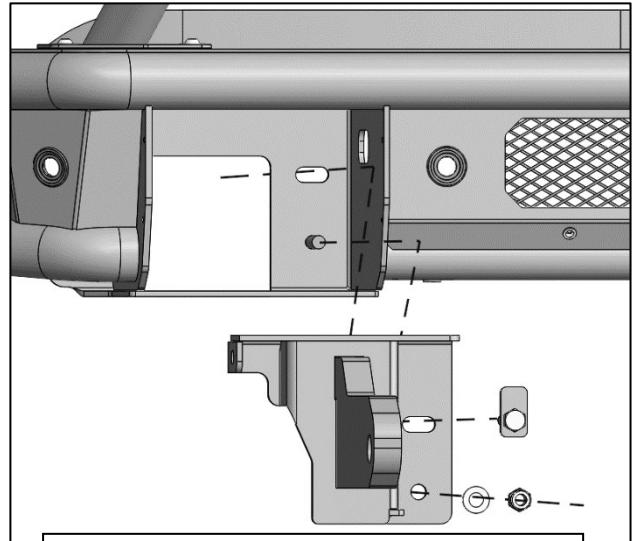

(Fig 5) Remove Standard Shackle Mount

2

Follow (Fig 6 – 10) to assemble and attach Fairlead Plate, then connect Winch Tray to HD4 Bumper.

- (2) 8mm Button Head Bolt
- (2) 8mm Flat Washer
- (2) 8mm Hex Nut

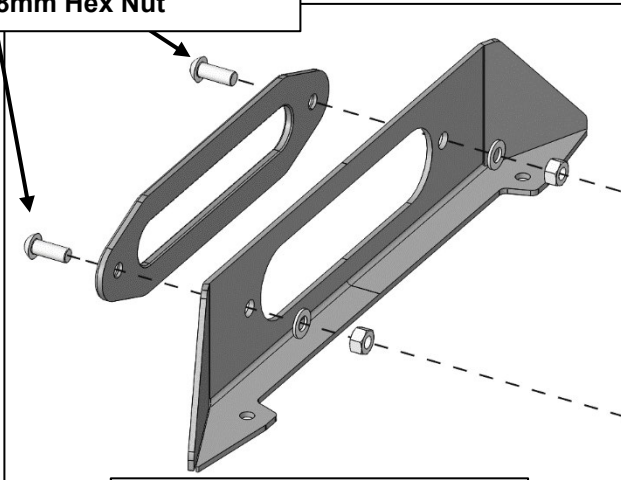

(Fig 6) Assemble Fairlead Plate

- (2) 8mm Button Head Bolt
- (4) 8mm Flat Washer
- (2) 8mm Lock Washer
- (2) 8mm Hex Nut

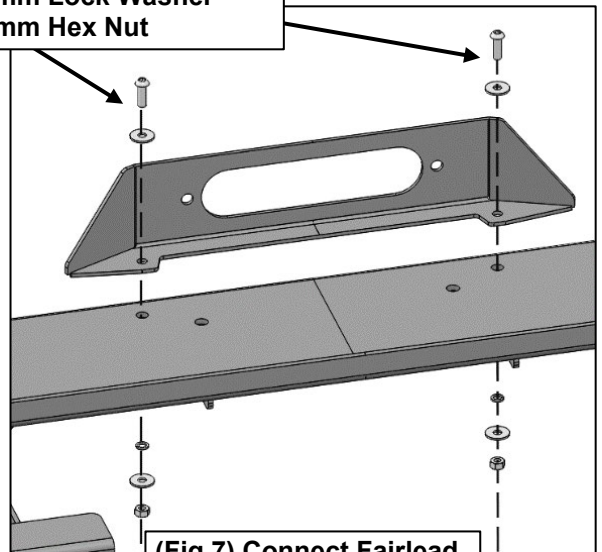

(Fig 7) Connect Fairlead Plate to Winch Tray

12mm Single Bolt Plate

(1) 12mm x 32mm Flat Washer
(1) 12mm Lock Washer
(1) 12mm Hex Nut

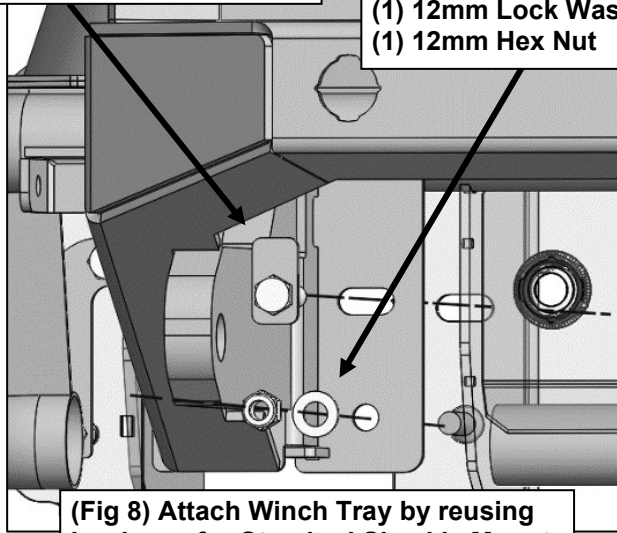

(Fig 8) Attach Winch Tray by reusing hardware for Standard Shackle Mount

(1) Single Bolt Plate
(1) Plastic Retainer

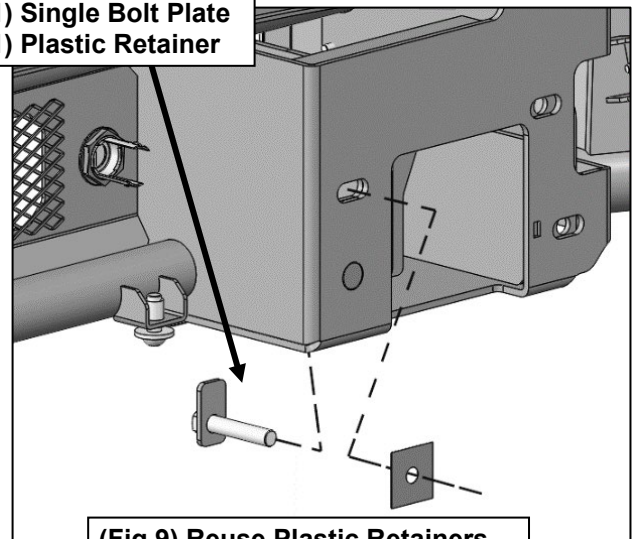

(Fig 9) Reuse Plastic Retainers to thread onto Bolt Plate to hold in place for Bumper installation

(2) Plastic Retainers

(1) Double Bolt Plate

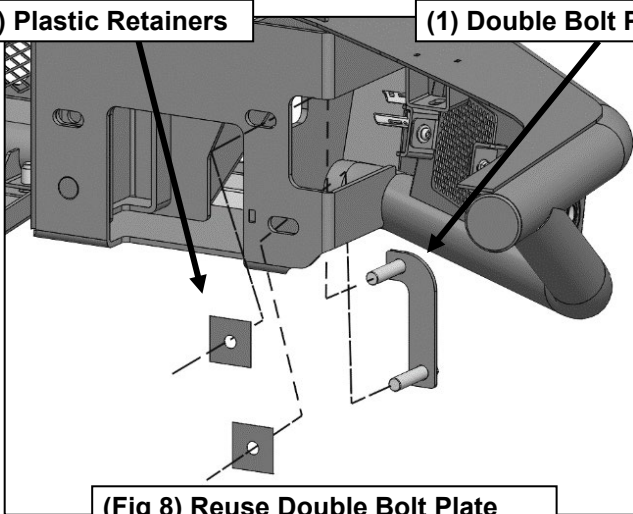

(Fig 8) Reuse Double Bolt Plate and Plastic Retainers to hold Plate in place for Bumper installation

(1) 12mm Hex Bolt
(1) 12mm Lock Washer
(1) 12mm Flat Washer
(1) 12mm Hex Nut

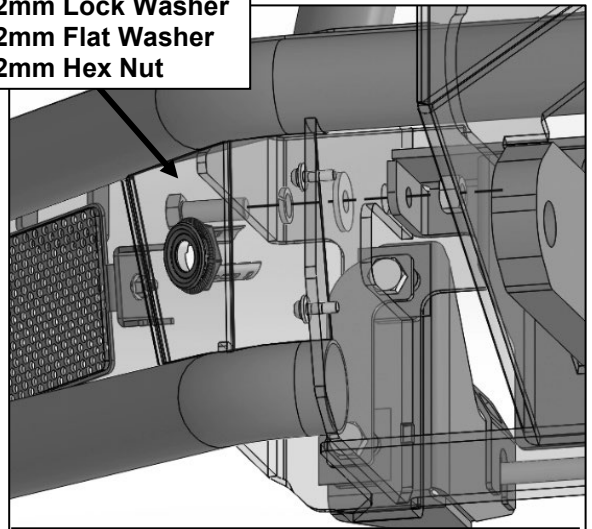

(Fig 9) Attach Winch Tray to Bumper reusing side mounting hardware

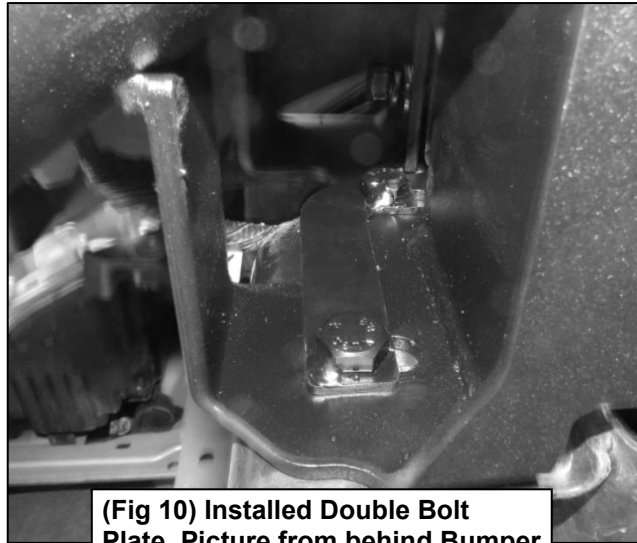

(Fig 10) Installed Double Bolt Plate. Picture from behind Bumper

3 Follow (Fig 11 – 15) to reattach bumper to Support Brackets, then reattach U-Covers.

(3) 12mm Flat Washers
(3) 12mm Lock Nuts

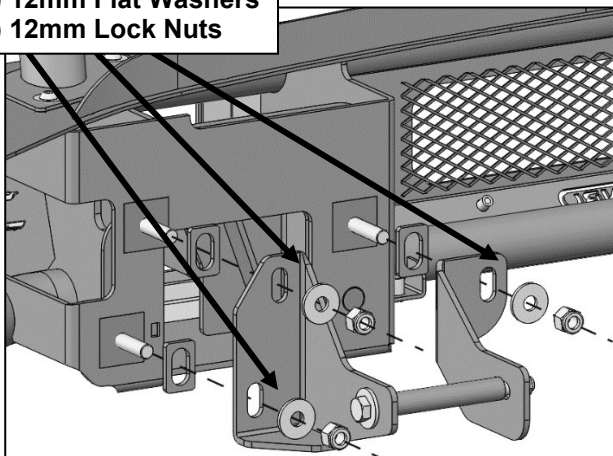

(Fig 11) Attach Bumper to Support Brackets

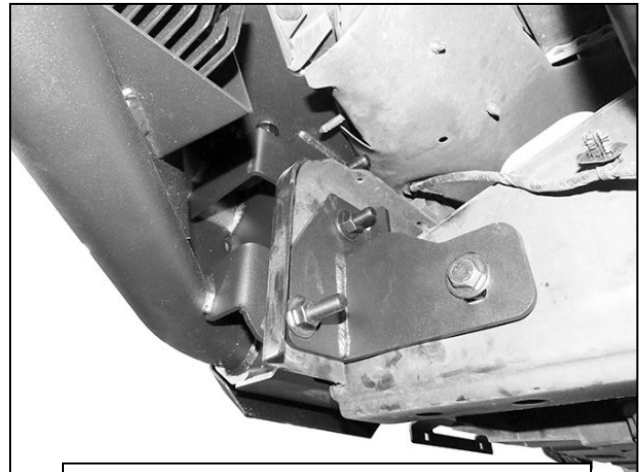

(Fig 12) Driver/left side of Bumper installed. Pictured from behind Bumper

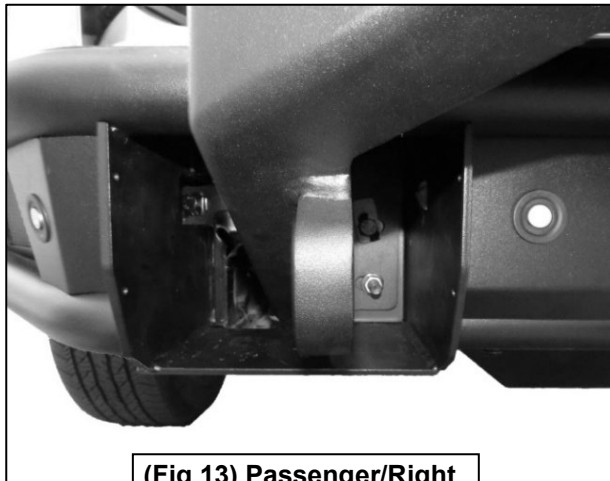

(Fig 13) Passenger/Right side of Bumper installed

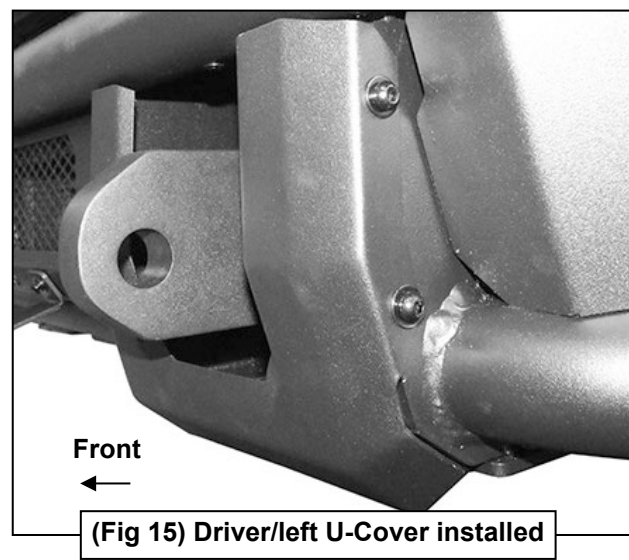
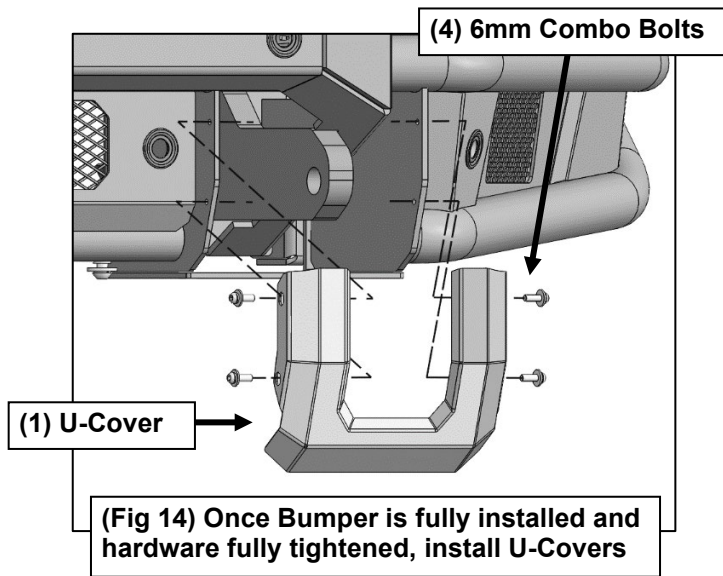

4

Ensure Bumper is level and all fasteners are tightened at this point. Installation is complete. Do periodic inspections to the installation to make sure that all hardware is secure and tight.

