



REDROCK TC1 RUNNING BOARD

SKU #: T601976 / T601977

FITS:

- 2015-Up F-150 SuperCrew Cab
- 2022-Up F-150 Lightning EV SuperCrew Cab
- 2017-Up F-250/F-350/F-450/F-550 Super Duty Crew Cab



60-120 min





Cutting Not Required



Drilling Not Required

Torque & Tools

Fastener Size	Tightening Torque (ft-lbs)	Wrench Required	Allen Wrench Required	
				
<input type="checkbox"/> 6mm	<input type="checkbox"/> 7-8.5		<input type="checkbox"/> 10mm	<input type="checkbox"/> 4mm
<input checked="" type="checkbox"/> 8mm	<input checked="" type="checkbox"/> 18-20		<input checked="" type="checkbox"/> 13mm	<input type="checkbox"/> 5mm
<input type="checkbox"/> 10mm	<input type="checkbox"/> 35-40		<input type="checkbox"/> 16mm	<input type="checkbox"/> 6mm
<input type="checkbox"/> 12mm	<input type="checkbox"/> 60-70		<input type="checkbox"/> 18mm	<input type="checkbox"/> 8mm

BEFORE INSTALLATION

REMOVE CONTENTS FROM BOX. VERIFY ALL PARTS ARE PRESENT. READ INSTRUCTIONS CAREFULLY BEFORE STARTING INSTALLATION. ASSISTANCE IS RECOMMENDED.

Part List

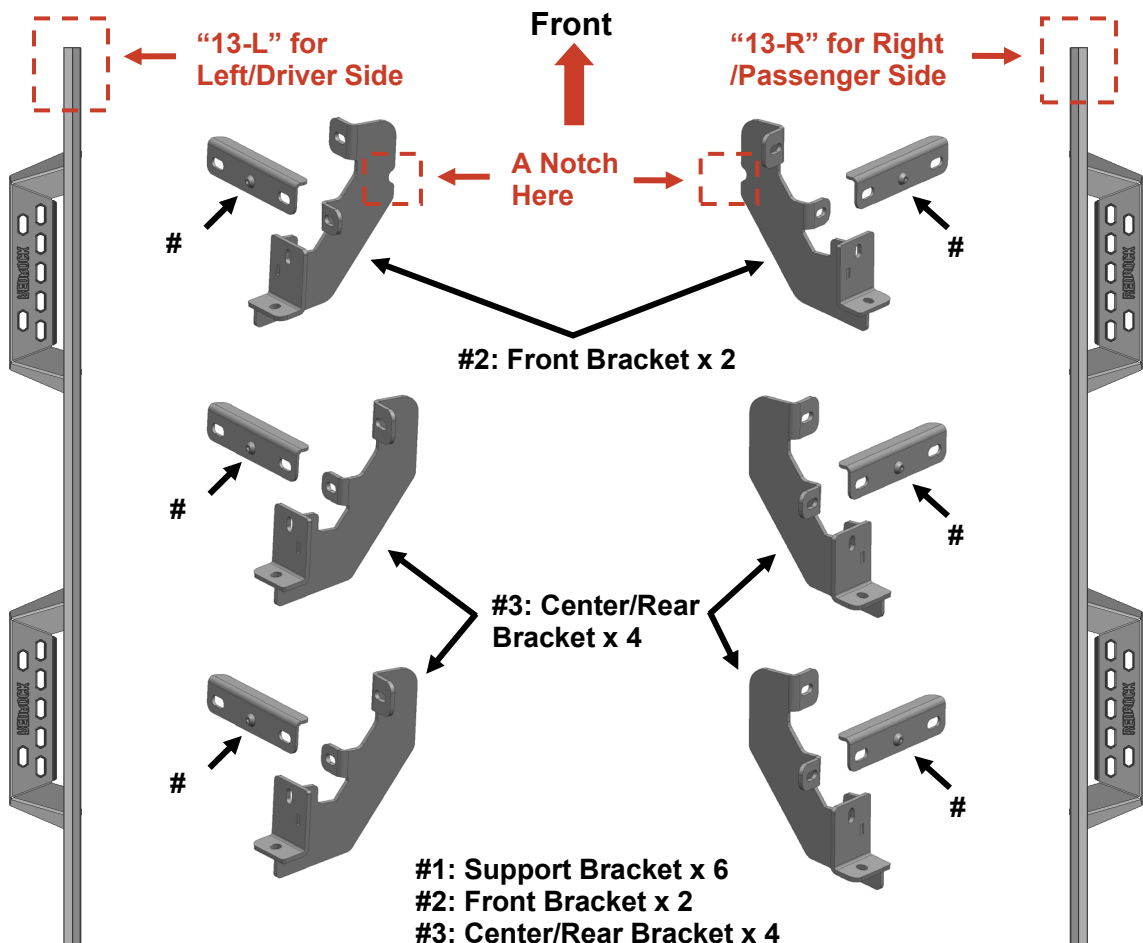

REDROCK

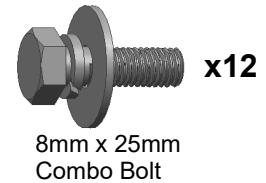
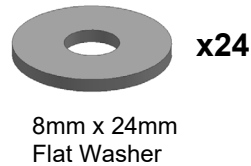
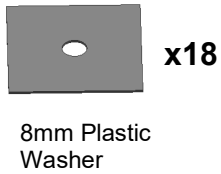

PLEASE NOTE THAT THE FOLLOWING PICTURES ARE BASED ON THE PASSENGER SIDE INSTALLATION

STEP 1

Start the installation under the Passenger/Right side of the vehicle. Locate the front factory mounting location along the inner side of the body, **(Fig 1)**. Use a wire brush or thread chaser die to remove excess paint and/or undercoating from all studs.

FIG 1

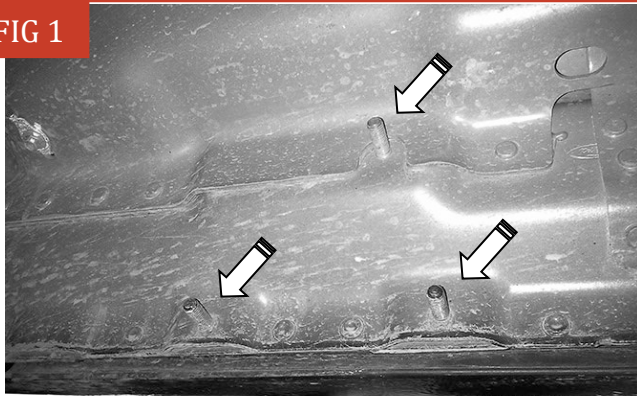

(Fig 1) Example of typical mounting location

STEP 2

Slide (1) Plastic Washer over each of the (3) factory mounting studs in the body panel, **(Fig 2)**. **IMPORTANT:** The Plastic Washers are designed to prevent corrosion between the aluminum body panel and the steel mounting brackets. **Do not install the Brackets without the Plastic Washers.**

FIG 2

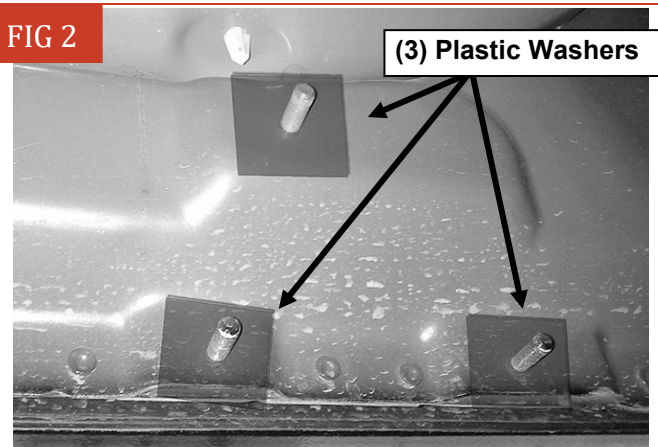

(Fig 2) Thread Plastic Washers onto all mounting studs

STEP 3

Select (1) Support Mounting Bracket (#1). Attach the Bracket to the studs with (2) 8mm Flat Washers and (2) 8mm Nylon Lock Nuts, **(Figs 3-4)**. Do not tighten hardware.

FIG 3

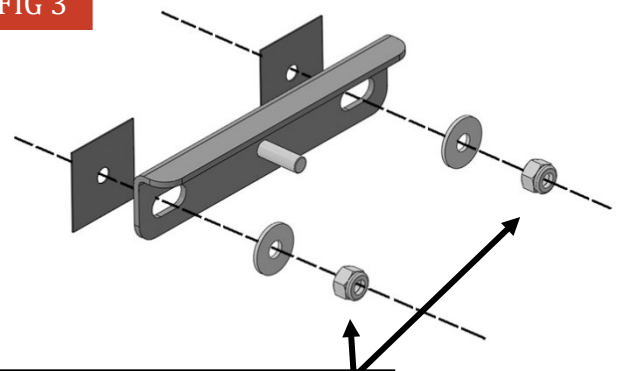

(Fig 3) Attach (1) Support Bracket (#1) to the threaded studs

REDROCK

FIG 4



(Fig 4) Example of the Support Bracket (#1) attached to the threaded studs

FIG 6



(Fig 6) Example of the Mounting Bracket attached to the upper mounting stud and Support Bracket

STEP 4

Then attach (1) Front Mounting Bracket (#2) to the upper factory mounting stud and support bracket with (1) Plastic Retainer, (2) 8mm Flat Washers, and (2) 8mm Nylon Lock Nuts, (Figs 5-6). **Note:** There is a notch on the back of the Front bracket.

FIG 5

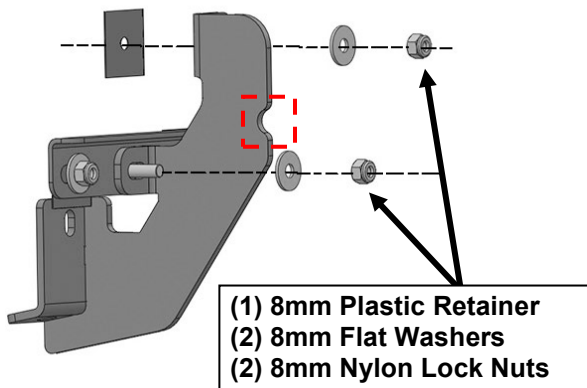

(Fig 5) Attach Front Mounting Bracket (#2) to the upper mounting stud and Support Bracket

STEP 5

Repeat **Step 3—4** to attach the remaining (2) Support Mounting Brackets (#1) and (2) Center/Rear Mounting Brackets (#3) to the center and rear mounting locations along the body panel, (Figs 7-8).

FIG 7



(Fig 7) Passenger/Right Center mounting location

REDROCK

FIG 8

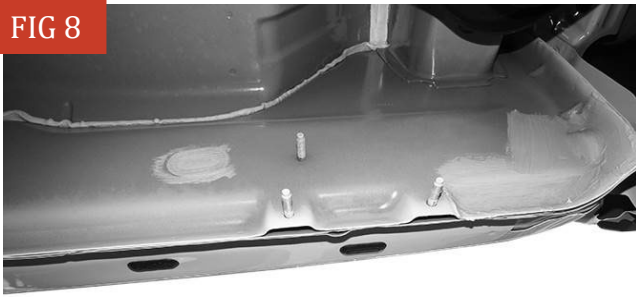

→
Rear

(Fig 8) Passenger/Right Rear mounting location

STEP 6

Select the Passenger/Right Running Board.

NOTE: The Passenger/Right Running Board will have a "13-R" on the front. Attach the Running Board to the Mounting Brackets with (6) 8mm Combo Bolts, (Fig 9).

FIG 9

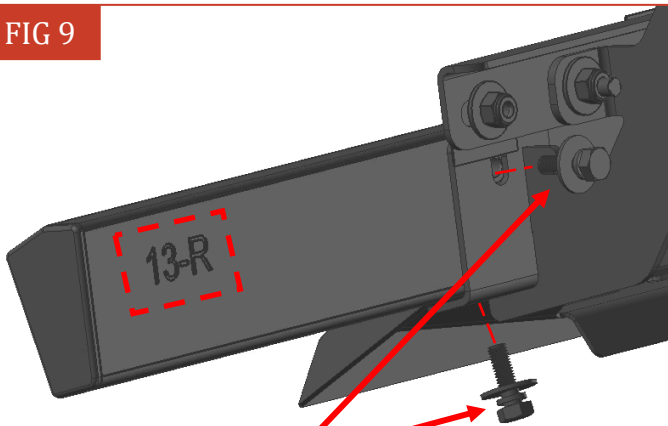

(2) 8mm Combo Bolts

(Fig 9) Attach the Passenger/Right Running Board to the Mounting Brackets

STEP 7

Level and adjust the Running Board and tighten all hardware.

STEP 8

Repeat **Steps 1—7** to attach Driver/Left Running Board.

STEP 9

Do periodic inspections to the installation to make sure that all hardware is secure and tight.

Attention

To protect your investment, do not use any type of polish or wax that may contain abrasives that could damage the finish.

Mild soap may be used also to clean the Running Boards.