



**General Policy**

All core returns must be,

- like for like, no mixed models
- drained of all fluids (\$50 Charge)
- be returned in the original packaging
- Part Disassembled
- No junkyard cores (core must have been removed from vehicle)
- No fire damage
- Free of excessive Rust or Water Damage

Returned cores that fail to follow the above conditions will be disallowed and scrapped or returned at the customer's expense. Freight and removal damage are not covered. BD Diesel reserves the right to adjudicate cores as it sees fit and may deviate from its policy.

**BD FUEL INJECTION CORE ACCEPTANCE POLICY**

Model	Deduction	No Credit
P7100 Injection Pump	<ul style="list-style-type: none"> <li>• AFC Housing Damaged (25% Deduction)</li> <li>• Governor Housing Damaged Front or Back (25% Deduction)</li> </ul>	<ul style="list-style-type: none"> <li>• Contaminated/Bio Diesel</li> <li>• Damaged Camshaft on 911/913 pumps.</li> <li>• Main Body Damaged</li> </ul>
Bosch VE Pump	<ul style="list-style-type: none"> <li>• AFC Housing Damaged (25% Deduction)</li> <li>• Cold Advanced Housing Damaged (50% Deduction)</li> <li>• Governor housing damaged front or back (25% deduction)</li> <li>• Main Body Damaged (50% Deduction)</li> </ul>	<ul style="list-style-type: none"> <li>• Contaminated/Bio Diesel</li> <li>• Seized Head (Does not turn)</li> </ul>
CP3		<ul style="list-style-type: none"> <li>• Contaminated/Bio Diesel</li> <li>• Seized (Does not turn)</li> <li>• Catastrophic Shaft Failure (Frost Plugs Damaged or Missing)</li> <li>• Front Cover Damaged</li> </ul>
VP44	<ul style="list-style-type: none"> <li>• Damaged Electronics (50% Deduction)</li> </ul>	<ul style="list-style-type: none"> <li>• Contaminated/Bio Diesel</li> <li>• Seized Head (Does not turn)</li> </ul>
Common Rail Injectors	<ul style="list-style-type: none"> <li>• Solenoid melted or destroyed, stretched terminals (25% Deduction)</li> <li>• 5.9/6.7 Broken Solenoid Terminal Divider (No Deduction)</li> </ul>	<ul style="list-style-type: none"> <li>• Contaminated/Bio Diesel</li> <li>• Damaged Body</li> </ul>
Mechanical Injectors		<ul style="list-style-type: none"> <li>• Contaminated/Bio Diesel</li> <li>• Damaged Body</li> </ul>

**BD TURBOCHARGER CORE ACCEPTANCE POLICY**

Turbo Model/ Application	Deduction	No Credit
Cummins ISX VGT Air or Electronic Actuated	<ul style="list-style-type: none"> <li>• Damaged Electronics (50% Deduction)</li> <li>• Missing Clamps (25% Deduction)</li> <li>• Missing Parts or Actuators (50% Deduction)</li> <li>• Turbine Wheel Separation (50% Deduction)</li> </ul>	<ul style="list-style-type: none"> <li>• Knock Off Models (Not Genuine)</li> <li>• Part Disassembled</li> </ul>
Caterpillar (Ball Bearing) Models		<ul style="list-style-type: none"> <li>• Knock Off Models (Not Genuine)</li> <li>• Wheel Separation</li> </ul>
Caterpillar (Standard Turbocharger) 704604-9007, 704604-9011		<ul style="list-style-type: none"> <li>• Knock Off Models (Not Genuine)</li> <li>• Turbo with 3 support Webs</li> </ul>

Detroit Diesel VGT	<ul style="list-style-type: none"> <li>• Damaged Electronics (50% Deduction)</li> </ul>	<ul style="list-style-type: none"> <li>• Knock Off Models (Not Genuine)</li> <li>• Wheel Separation</li> </ul>
Ford 6.4 Powerstroke	<ul style="list-style-type: none"> <li>• Missing Parts or Actuators (50% Deduction)</li> </ul>	<ul style="list-style-type: none"> <li>• Knock Off Models (Not Genuine)</li> <li>• Part disassembled</li> <li>• Wheel Separation</li> </ul>
Ford 6.7 Powerstroke	<ul style="list-style-type: none"> <li>• Missing Parts or Actuators (50% Deduction)</li> </ul>	<ul style="list-style-type: none"> <li>• Wheel Separation</li> </ul>
GM 6.6 L5P	<ul style="list-style-type: none"> <li>• L5D Version (due to incorrect compressor cover) (25% Deduction)</li> <li>• Missing Parts or Actuators (50% Deduction)</li> </ul>	<ul style="list-style-type: none"> <li>• Knock Off Models (Not Genuine)</li> <li>• Wheel Separation</li> </ul>
Dodge Cummins 6.7 HE351VG/HE300VG	<ul style="list-style-type: none"> <li>• Missing Parts or Actuators (50% Deduction)</li> </ul>	<ul style="list-style-type: none"> <li>• Knock Off Models (Not Genuine)</li> </ul>
Standard Turbochargers (All Models, Non VGT)	<ul style="list-style-type: none"> <li>• Damaged Electronics (50% Deduction)</li> <li>• Missing Clamps (25% Deduction)</li> <li>• Missing Parts or Actuators (50% Deduction)</li> </ul>	<ul style="list-style-type: none"> <li>• Knock Off Models (Not Genuine)</li> <li>• Wheel Separation</li> </ul>

The above criteria apply to customer core returns. The following criteria will apply for core purchases.

Deduction	No Credit
<ul style="list-style-type: none"> <li>• Cracked or Damaged due to freight</li> <li>• Damaged Electronics</li> <li>• Missing Parts or Actuators</li> <li>• Heavily Damaged Wheels and/or Shaft</li> <li>• Missing Clamps</li> <li>• Turbine Wheel Separation</li> <li>• Heavily Modified Turbochargers</li> </ul>	<ul style="list-style-type: none"> <li>• Knock Off Models (Not Genuine)</li> </ul>

## BD TRANSMISSION/TORQUE CONVERTOR CORE ACCEPTANCE POLICY

Model	Deduction	No Credit
Transmissions	<ul style="list-style-type: none"> <li>• Cracked Overdrive housings (\$100 Deduction)</li> <li>• 68rfe Cracked Case (25% Deduction)</li> <li>• Part disassembled (50% Deduction)</li> <li>• Missing Transmission Shipping Crate (\$200 Deduction)</li> <li>• Missing TC/Transmission bracket (\$50 Deduction)</li> </ul>	<ul style="list-style-type: none"> <li>• Cracked Case (Except 68rfe)</li> </ul>
Torque Convertors	<ul style="list-style-type: none"> <li>• Hub and Impeller damaged. (50% Deduction)</li> </ul>	<ul style="list-style-type: none"> <li>• Excessive corrosion</li> <li>• Part disassembled</li> </ul>
Valve Bodies	<ul style="list-style-type: none"> <li>• Missing electronics (25% Deduction)</li> </ul>	<ul style="list-style-type: none"> <li>• Excessive corrosion</li> <li>• Part disassembled</li> </ul>

## GENERAL CORE ACCEPTANCE POLICY

Model	Deduction	No Credit
EGR Cooler		<ul style="list-style-type: none"> <li>• Brackets broken</li> </ul>

Please note that all cores have a time eligibility restriction. Please see BD Terms & Conditions for further details. [https://cdn.bddiesel.com/downloads/bd\\_terms\\_general.pdf](https://cdn.bddiesel.com/downloads/bd_terms_general.pdf)



***DOWNLOAD COLOUR  
INSTALL MANUALS AT  
[www.bddiesel.com](http://www.bddiesel.com)***



# **RoadMaster 10R80 Transmission**

<b>Transmission Only</b>	<b>Transmission + Torque Converter</b>	
<b>1064612</b>	<b>1064612SS</b>	<b>2018-2020 F150 V6 2WD</b>
<b>1064614</b>	<b>1064614SS</b>	<b>2018-2020 F150 V6 4WD</b>
<b>1064622</b>	<b>1064622SS</b>	<b>2018-2020 F150 V8 2WD</b>
<b>1064624</b>	<b>1064624SS</b>	<b>2018-2020 F150 V8 4WD</b>

Ford OEM or equivalent scan tool required for installation of solenoid strategy code.

# **Table of Contents**

Table of Contents.....2

Introduction .....2

Tools Required for Installation .....2

Fluid Requirements.....2

Removal/Installation.....3

    Removal .....3

    Installation .....14

Line Pressure Checks .....31

# **Introduction**

BD’s RoadMaster 10R80 is our remanufactured transmission made for stock or slightly upgraded F-150s. In this transmission we put in new OEM clutches and steels, increase line pressure, and install a new aluminum deep sump oil pan with a drain plug.

# **Tools Required for Installation**

- Ford tool, torque converter retainer – 307-346 (optional)
- 307-569 Disconnect Tool TOC Line (optional)
- Fluid suction gun or universal fluid dispenser for fluid fill
- Ford scan tool or equivalent for solenoid strategy programming and fill procedure

# **Fluid Requirements**

Ford Mercon ULV fluid (Part number XT-12-QULV).

The stock transmission total dry fill is 13 quarts.  
 For BD logo transmission pan the total capacity is 15.1 quarts.  
 For non-BD logo aluminum pan the total capacity is 14.9 quarts.

There is residual oil from the dyno test procedure left in the torque converter and transmission which will reduce the total capacity. Always confirm fill level using transmission fluid level indicator.



## Removal/Installation

Disconnect both vehicle batteries before installation for safety.

### Removal

1. Put the vehicle into NEUTRAL and lift it onto a hoist.

Remove all underbody shields.  
Remove skid plate

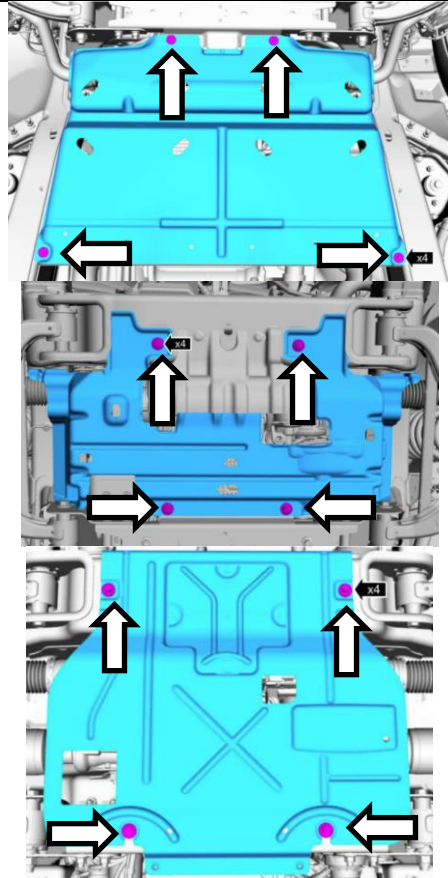

2. Open the starter motor plastic cap.

(1) Remove the starter solenoid battery cable nut and disconnect the cable.

(2) Remove the starter motor solenoid control wire nut and disconnect wire.

(3) Remove the start ground cable nut and disconnect cable.

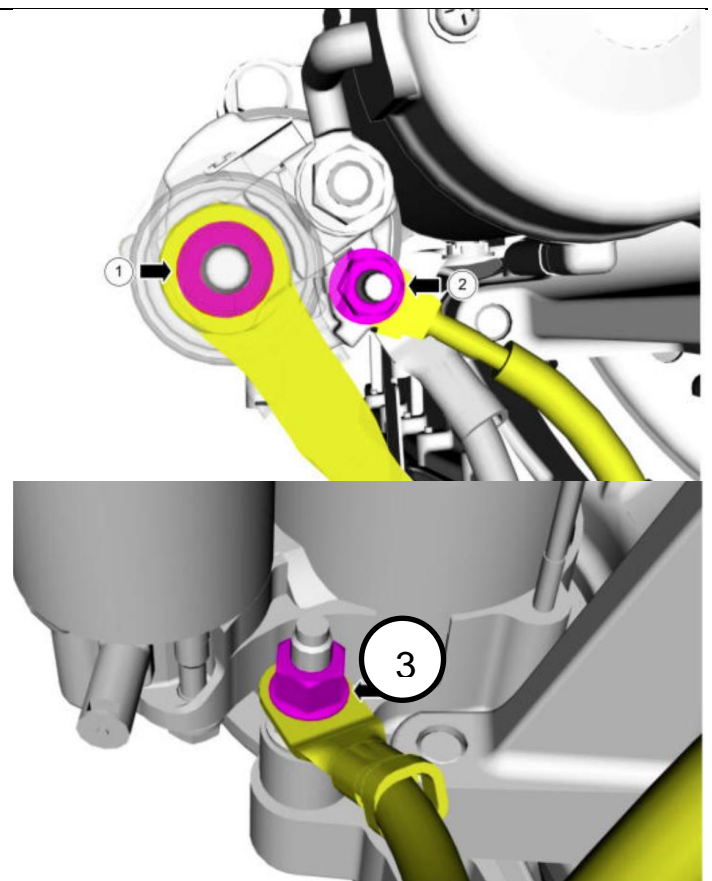

3. Remove the starter motor's three bolts and remove starter.

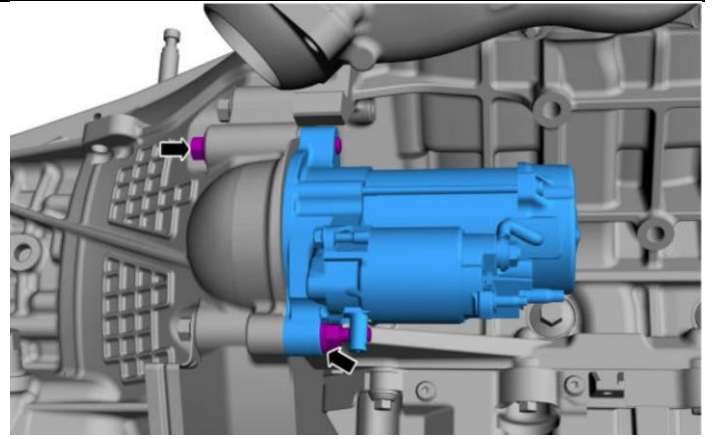

4. (1) Move the transmission fluid cooler inlet tube heat shield aside.  
(2) Disconnect the transmission fluid cooler inlet tube secondary latch.

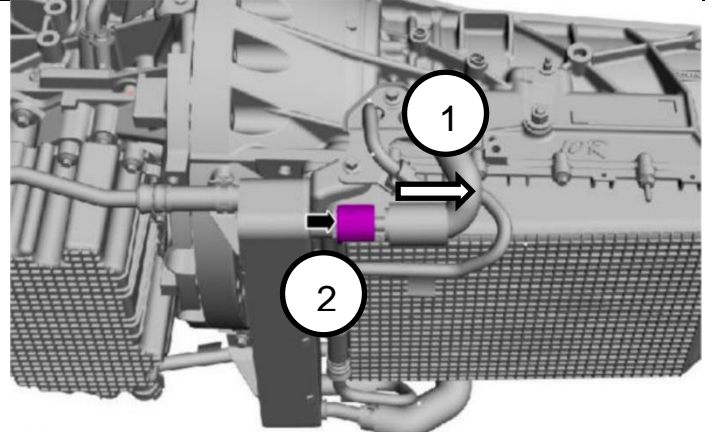

5. With the special tool (307-569), disconnect the transmission fluid cooler inlet tube from the cooler.

Note:

- Be ready to catch dripping fluid.

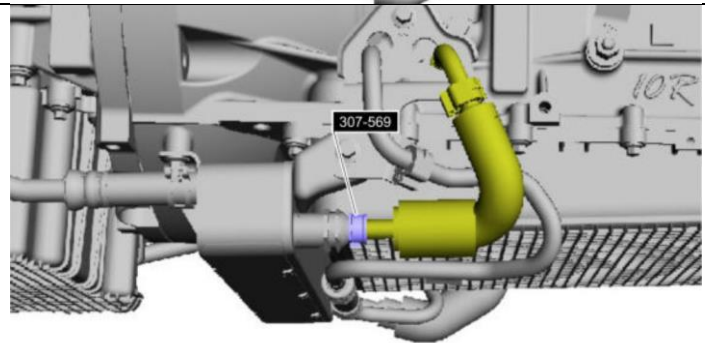

6. (1) Move the transmission fluid cooler outlet tube heat shield away.  
(2) Remove the transmission fluid cooler outlet tube secondary latch.

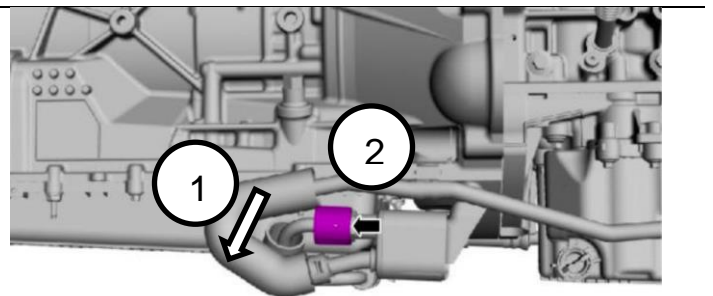

- 7. With the special tool (307-569), disconnect the transmission cooler outlet tube.

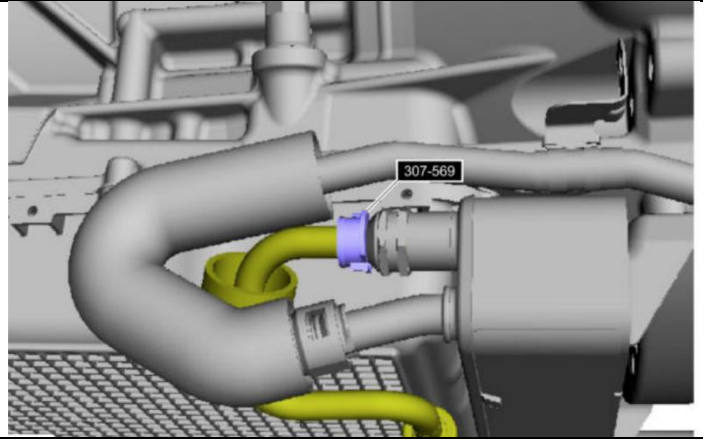

- 8. (1) Disconnect the coolant hoses from the cooler.
- (2) Loosen the coolant hose clamp.
- (3) Remove the cooler bolts.
- (4) Disconnect the cooler off of the hose and remove.

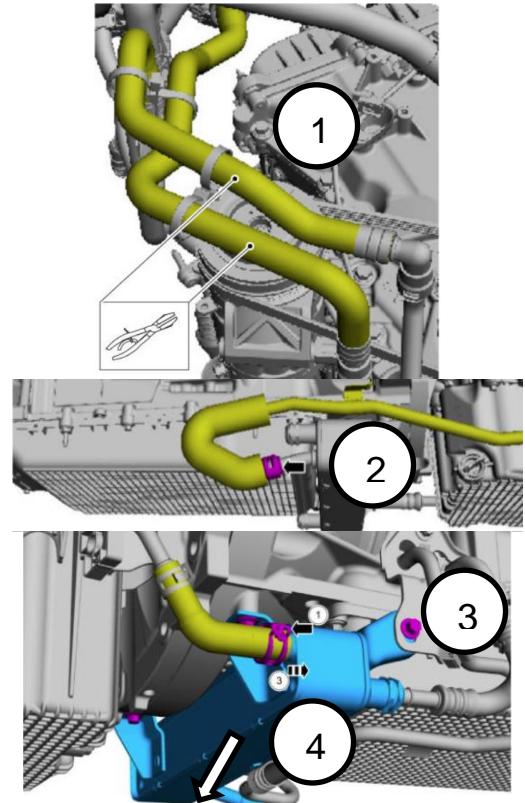

Note:

- You may want to clamp the hoses to minimize leaking coolant.

- 9. To maintain alignment during installation, index-mark the driveshaft flange to the pinion flange.

Remove the driveshaft flange to the pinions flange bolts.

Note:

- OEM specifications recommend to replace these bolts.

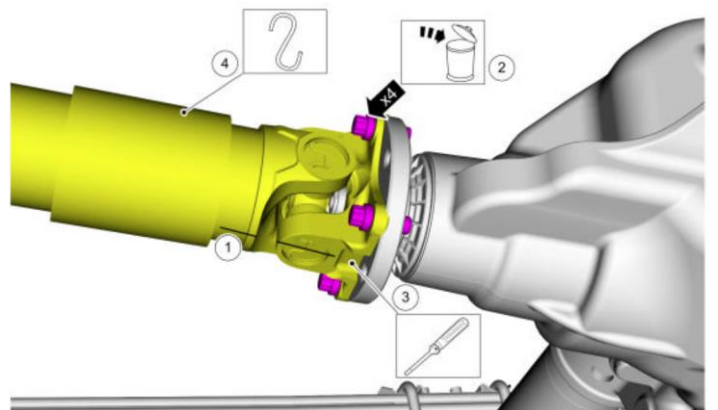

**For 2WD:**

- Index mark the driveshaft flange to the transmission flange for alignment when installing.

Remove the bolts and separate the driveshaft flange from the transmission flange.

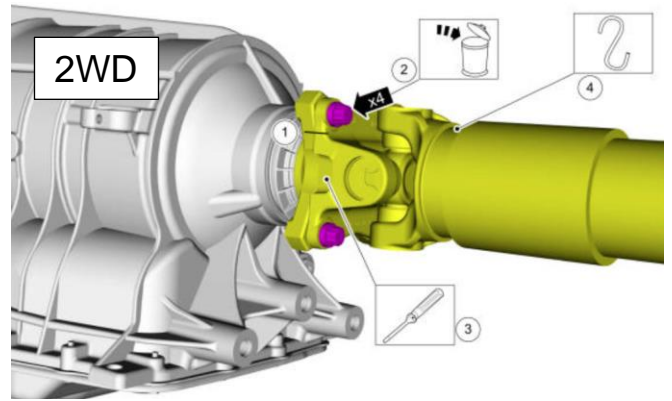

**Note:**

- OEM specifications recommend to replace these bolts.

**For 4WD**

- Slide the rear drive shaft out of the transfer case.

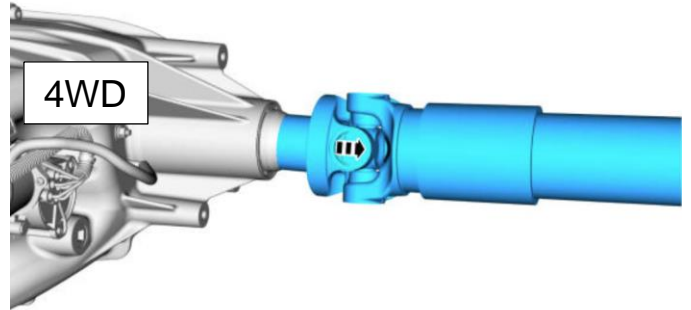

**If equipped with two-piece driveshaft.**

- Remove the carrier bearing bolts and driveshaft.

**Note:**

- OEM specifications recommend to replace these bolts.

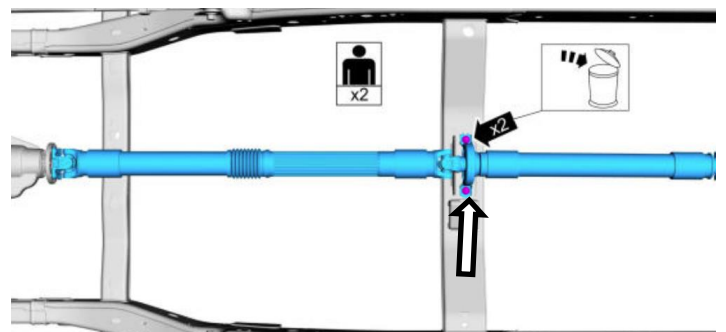

- Unbolt the stabilizer bar brackets and allow bar to swing down.

**Note:**

- OEM specifications recommend to replace these bolts.

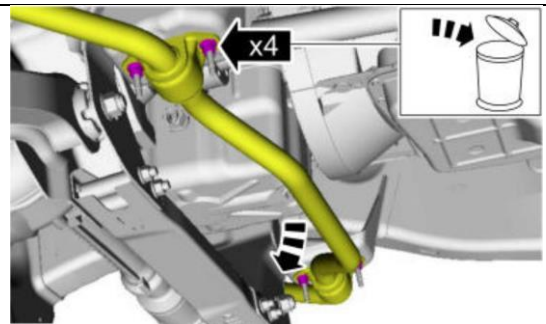

**Steps 14-17 is for 4WD  
Skip to step 18 for 2WD**

- 14. Index-mark the front driveshaft flange CV joint to the pinion flange cup, and then remove the bolts and retaining straps.

Note:  
OEM specifications recommend to replace these bolts.

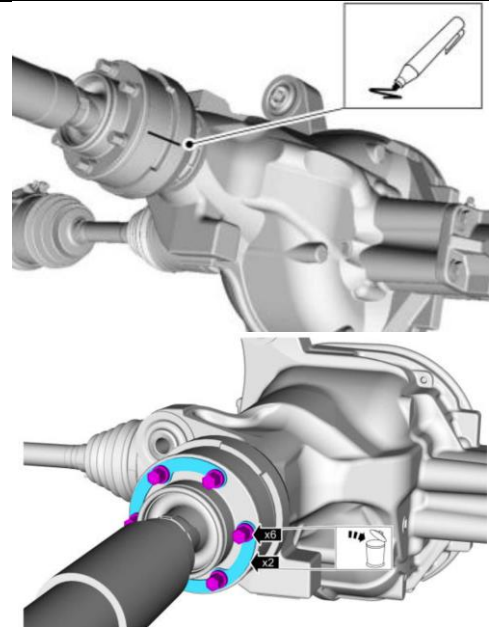

- 15. Index-mark the front driveshaft flange CV joint-to-transfer case flange cup and then remove bolts and retaining straps.

Note:  
• OEM specifications recommend to replace these bolts.

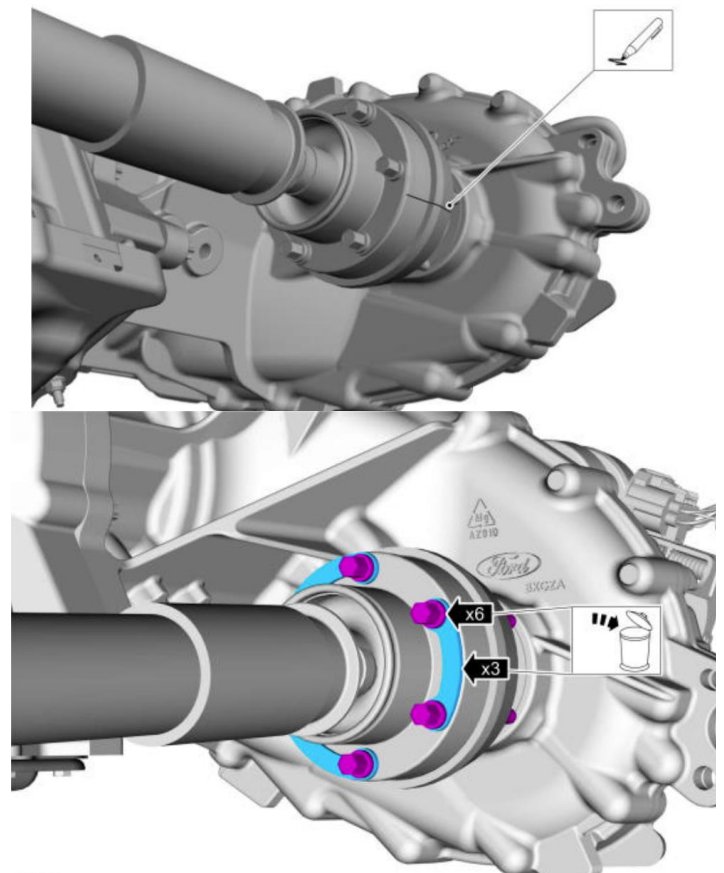

- 16. Remove the front driveshaft.

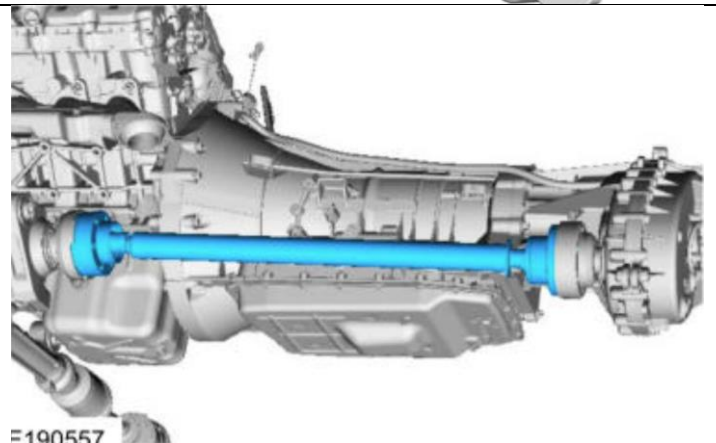

F190557

17. Remove the LH isolator cap and bolt.

Remove both RH and LH transmission insulator bolts.

Note:

- OEM specifications recommend to replace these bolts.

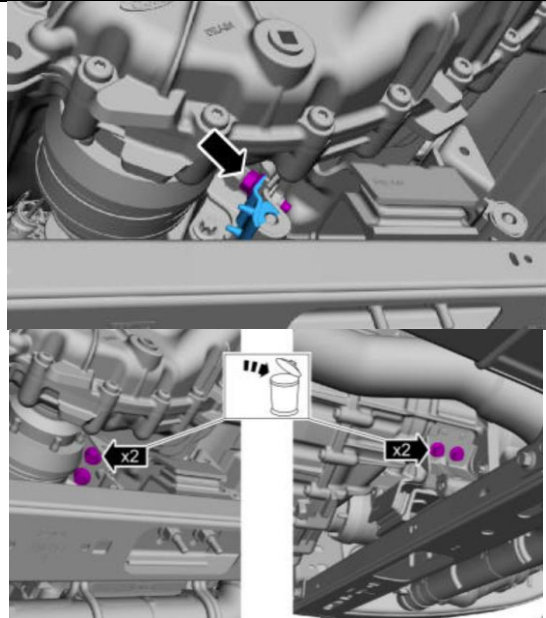

18. Remove the transmission fluid cooler tubes.

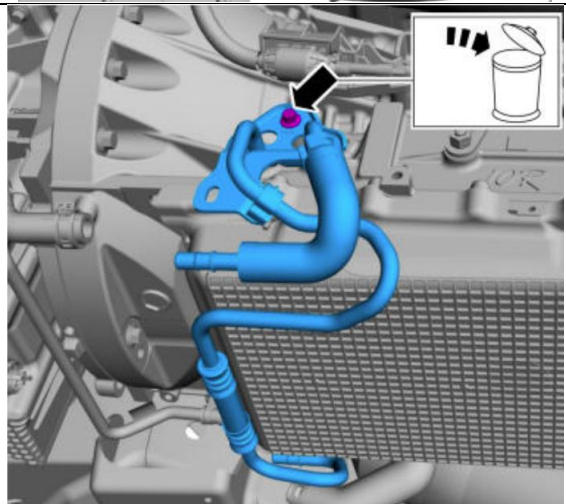

19. Remove the heatshields, and then remove the pan to drain the fluid.

Once fluid is drained, install pan back on. No need to torque.

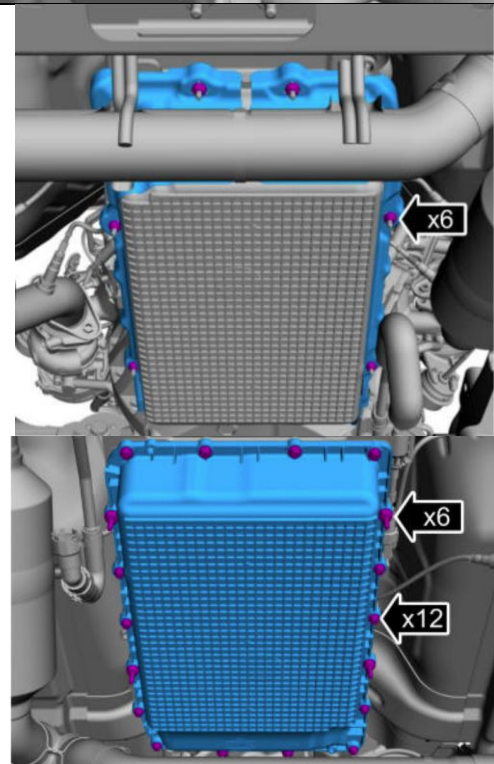

20. With a high-lift transmission jack, support the transmission securely!

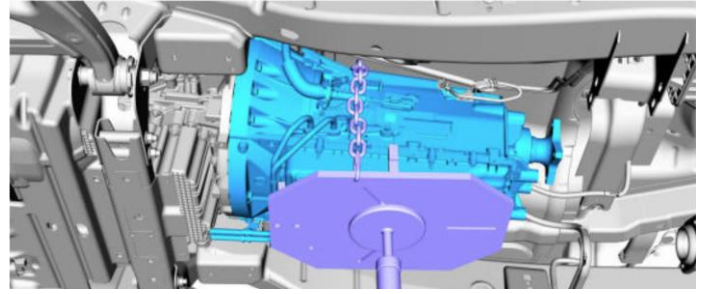

**Important:** Secure the transmission to the jack with a safety strap, and ensure the jack makes contact on the outer ribs of the pan.

21. Disconnect both the HO2S electrical connectors.

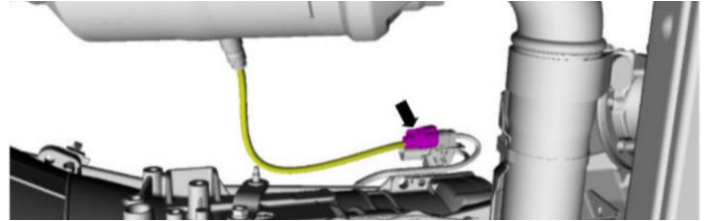
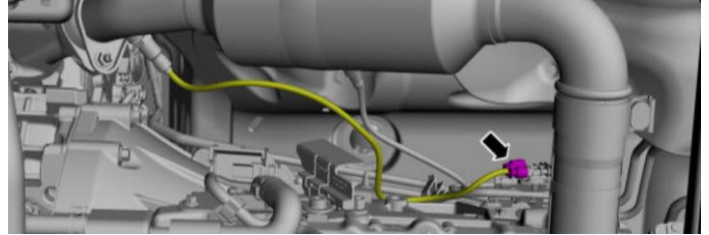

22. Remove the LH catalytic converter nut, then loosen the clamp to remove the catalytic converter.

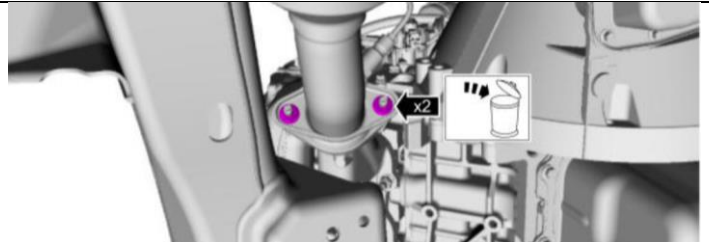

Note:

- OEM specifications recommend to replace these bolts.

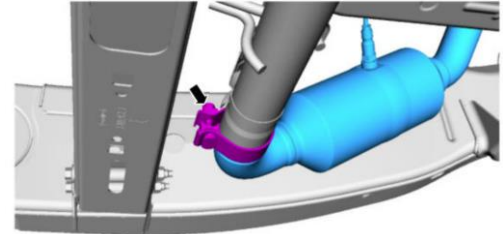

23. Remove x4 bolts and curved skid plate.

Next remove wiring harness on cross member by removing x2 bolts.

Position wiring harness aside.

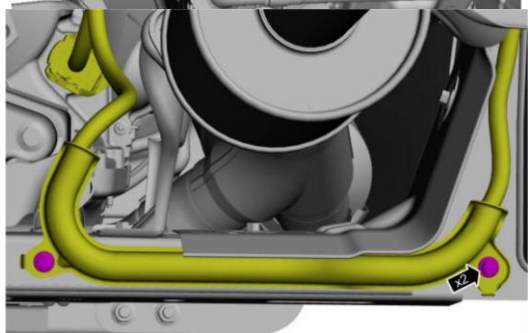
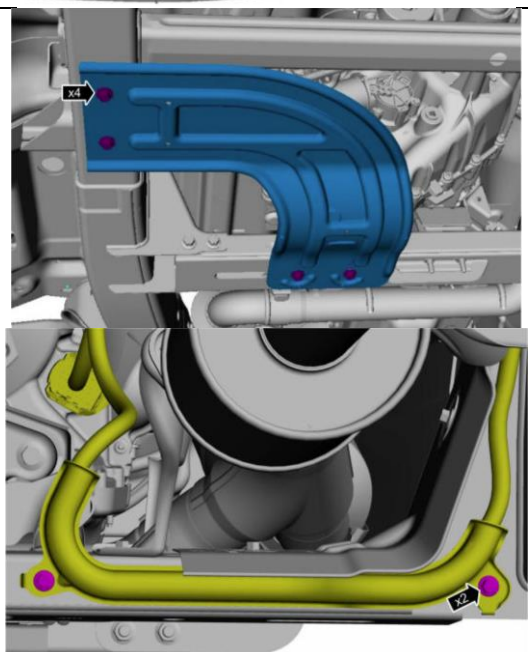

- 24. If equipped, remove both the LH and RH exhaust heat shield bolts from transmission crossmember.

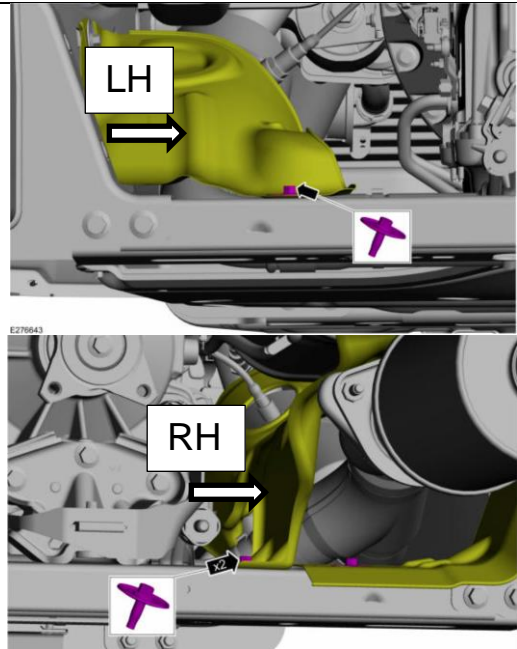

- 25. (1) Remove the transmission support crossmember fasteners.
- (2) Remove the transmission mount nuts and remove the transmission support crossmember.

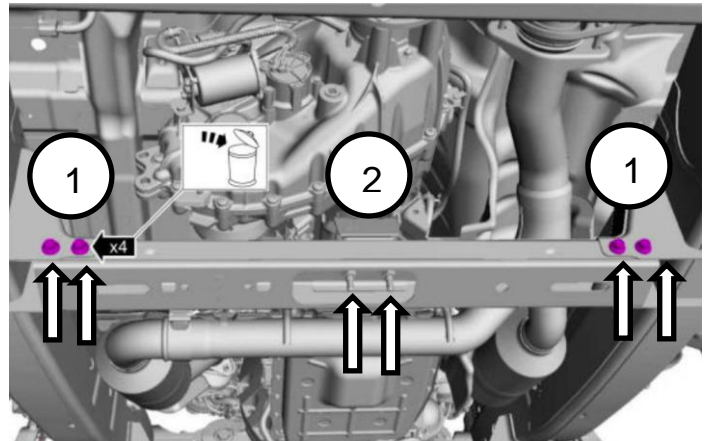

Note:

- OEM specifications recommend to replace these bolts.

**For 2WD**

- 26. Remove transmission support insulator bolts and washers and remove the support insulator.

Note:

- OEM specifications recommend to replace these bolts.

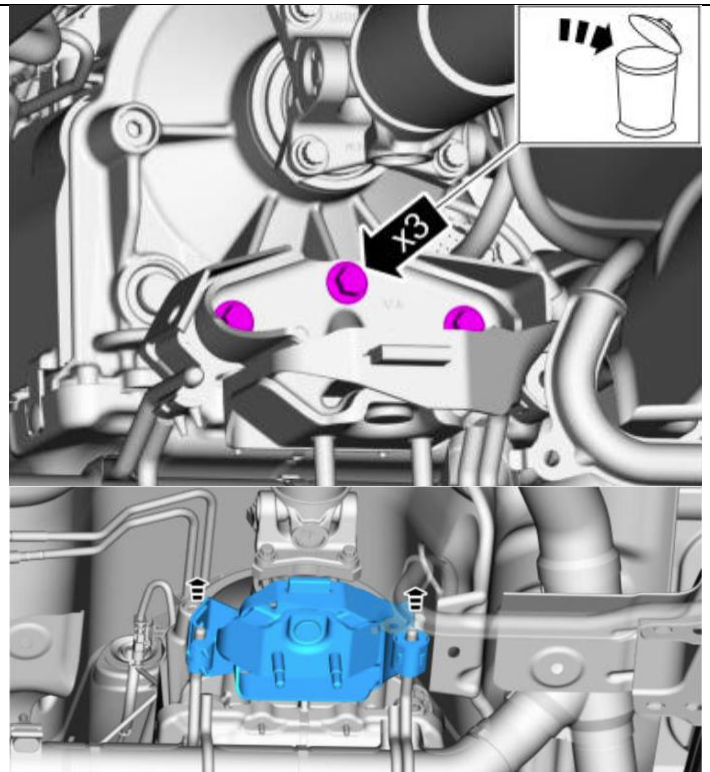

**For 4WD**

27. Remove transmission support insulator bolts.

Remove the support.

Note:

- OEM specifications recommend to replace these bolts.

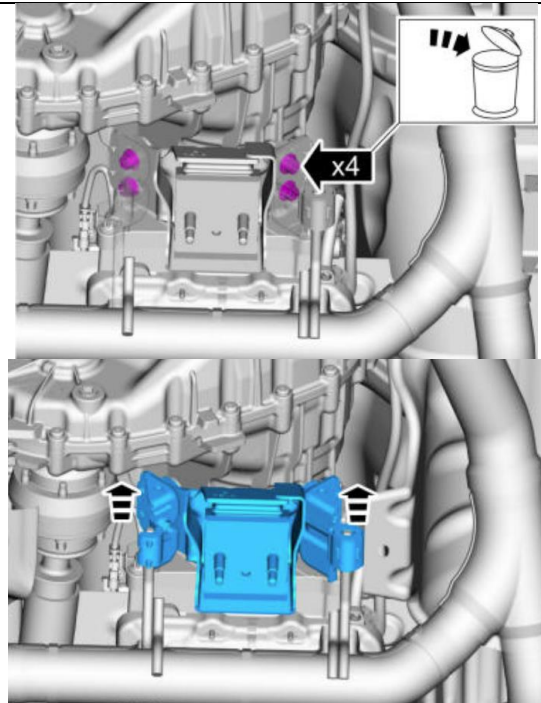

28. Disconnect RH catalyst monitor sensor and RH HO2S electrical connectors.

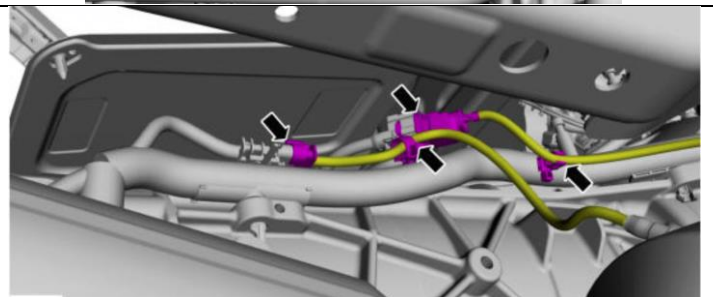

29. Remove bolts from the catalytic converter flange to the muffler inlet pipe.

Then remove catalytic converter.

Note:

- OEM specifications recommend to replace these bolts.

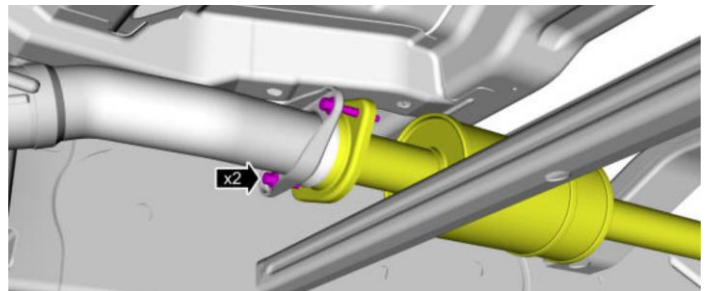

30. **If equipped**, remove splash shield by removing one bolt.

Then remove the bolts and disconnect the selector lever cable and move aside.

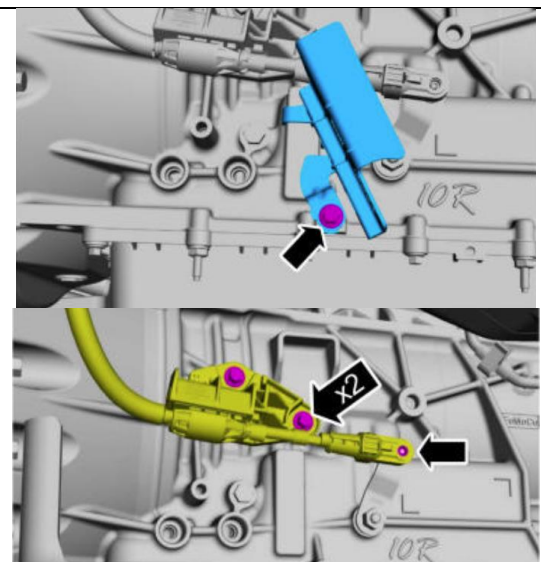

31. Remove fuel line bracket bolt.

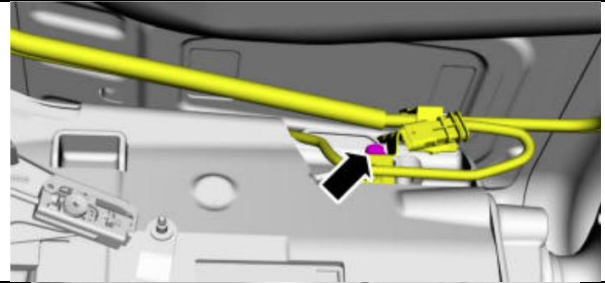

**For 4WD only**

32. Disconnect the transfer case vent tube.

Also remove the transfer case electrical connector.

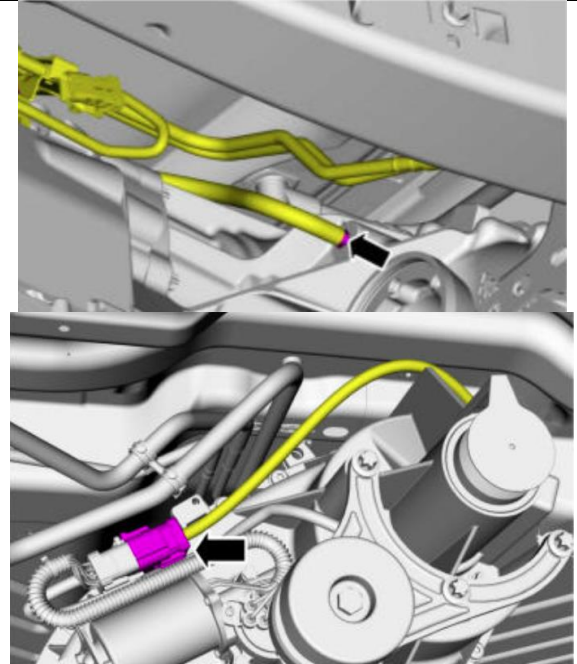

33. Disconnect the transmission electrical connector.

Remove the retainer, and move the wiring harness aside.

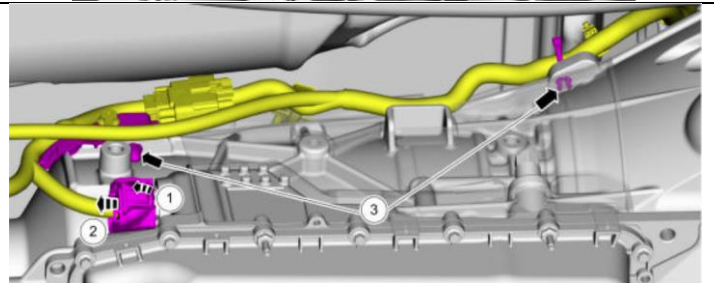

34. Remove the rubber torque converter nut access cover, then index mark one stud and flexplate for assembly.

Then remove torque converter nuts (qty 4).

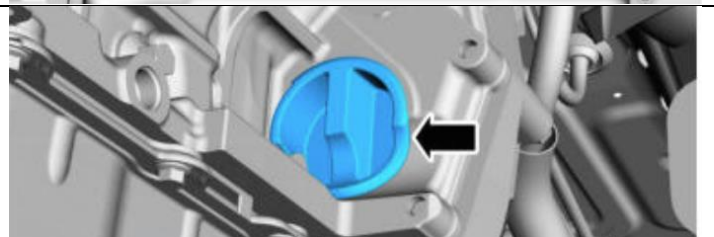

**Notes:**

- Using the crankshaft pulley bolt, turn the engine clockwise.
- OEM specifications recommend to replace these nuts.

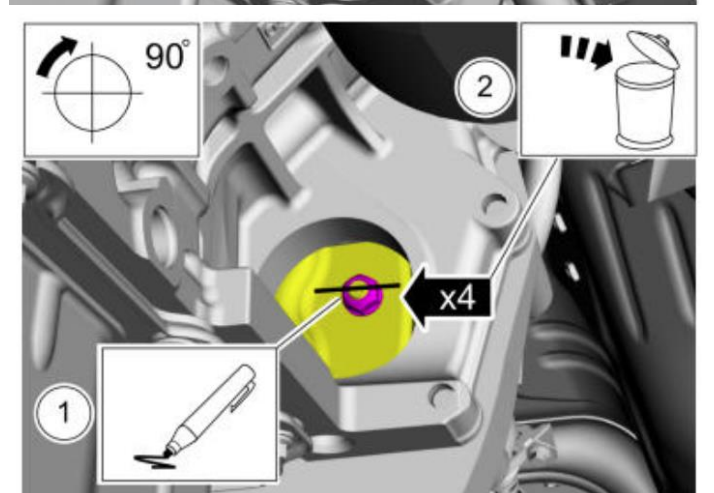

- 35. Remove all bellhousing bolts (qty 9).

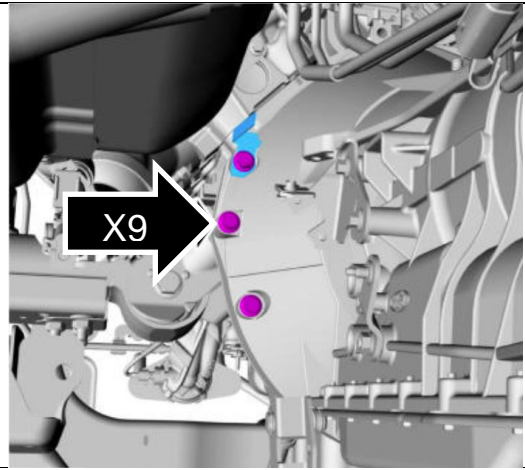

**For 2WD**

- 36. Using the high-lift transmission jack, remove the transmission.

Note:

- May use a torque converter retaining tool (307-346) if needed.

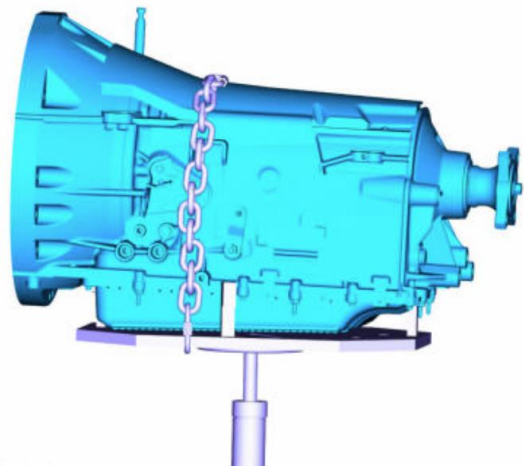

**For 4WD**

- 37. Ensure the transmission is secure on the transmission jack  
Slide transmission towards the rear of the vehicle.

Tilt the front of the transmission down while removing from vehicle.

Note:

- Important! Torque converter retaining tool (307-346) is recommended.

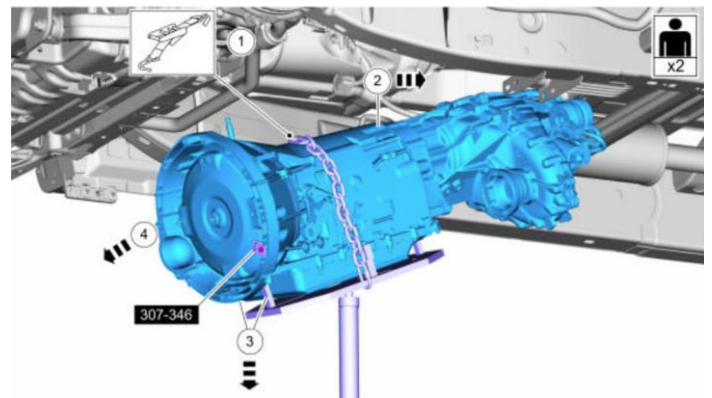

- 38. To remove the transfer case, remove the 9 bolts.

Note:

- OEM specifications recommend to replace these bolts.

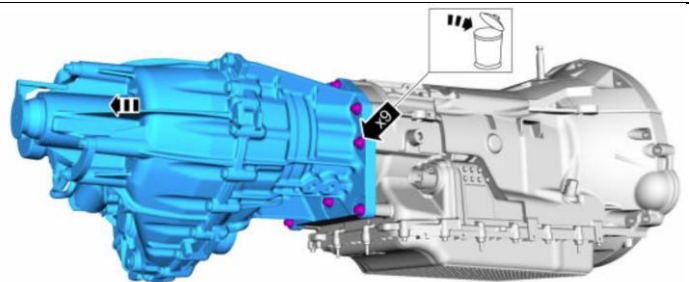

## Installation

1. Lubricate the torque converter pilot hub with Multi-Purpose Grease Spray.

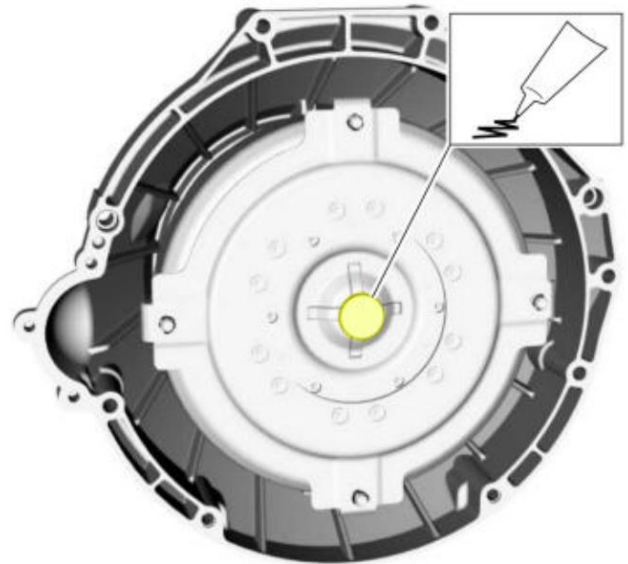

2. Install new dowel pins in the engine block if they were taken out during removal.

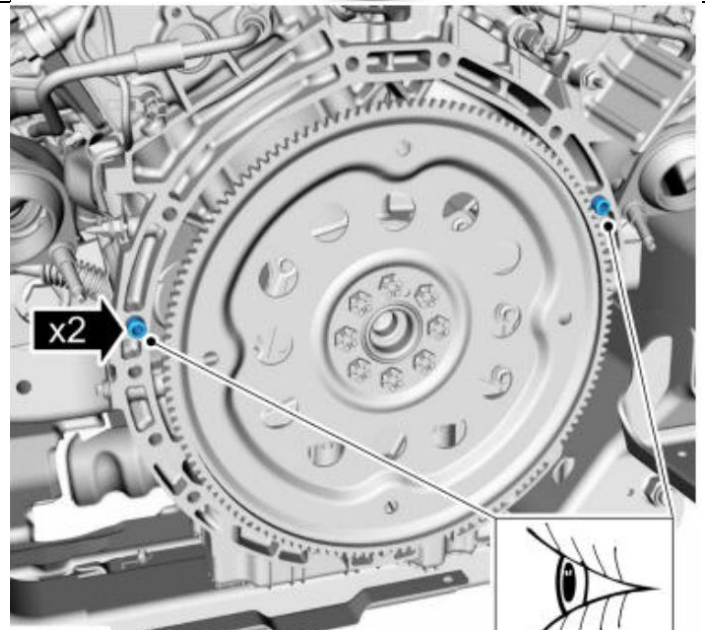

### For 4WD

3. Connect the transfer case with the 9 bolts.

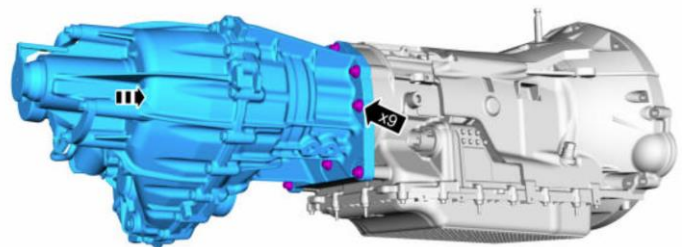

**Torque: 150lb.in (17Nm)**

Ensure that transmission is securely mounted onto the jack.

#### For 4WD

4. Tip front downwards (as shown) in order to put transmission in place.

#### For 2WD

5. Raise the level transmission into place.

#### Note:

- May use a torque converter retaining tool if needed.

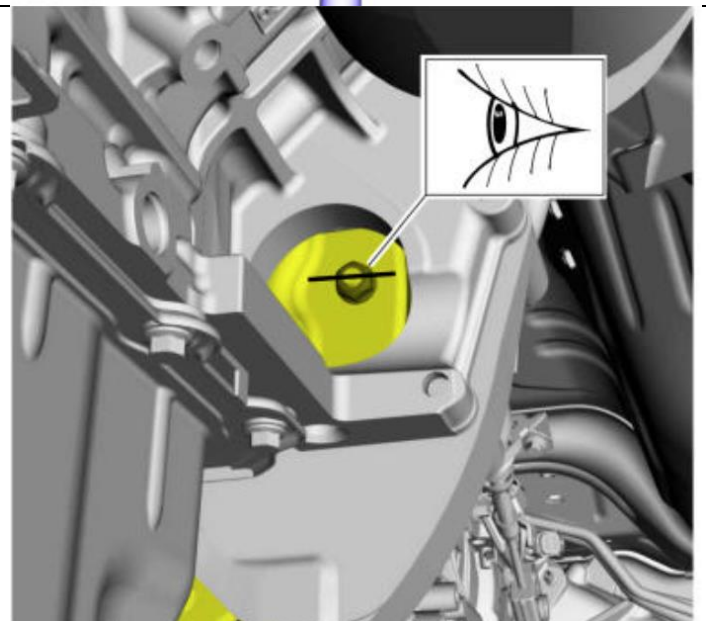
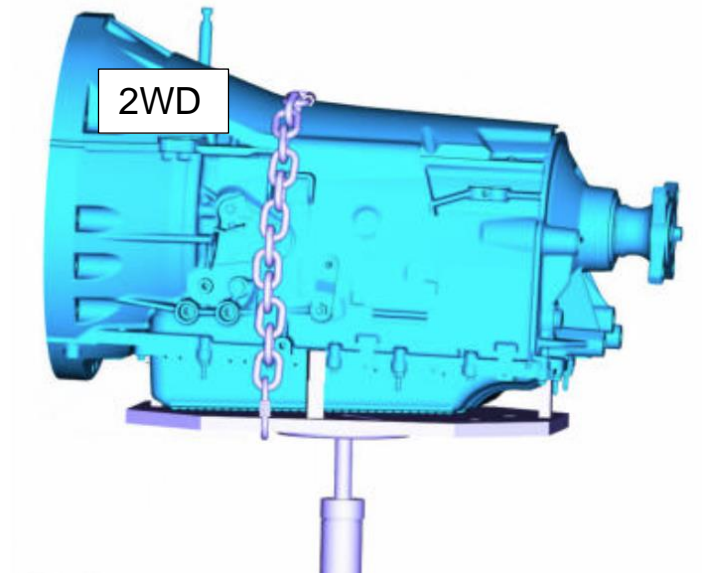
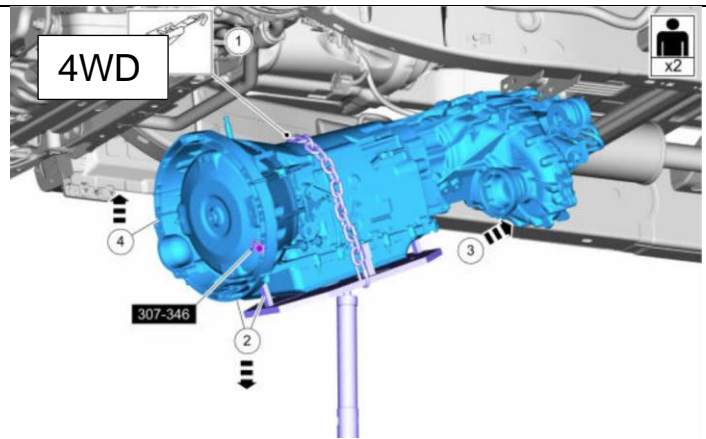

6. Align torque converter to the index-marks made during removal.

7. Install x3 top bellhousing bolts.  
Install x3 LH bellhousing bolts.  
Install x3 RH bellhousing bolt.

**Torque: 35lb.ft (48Nm)**

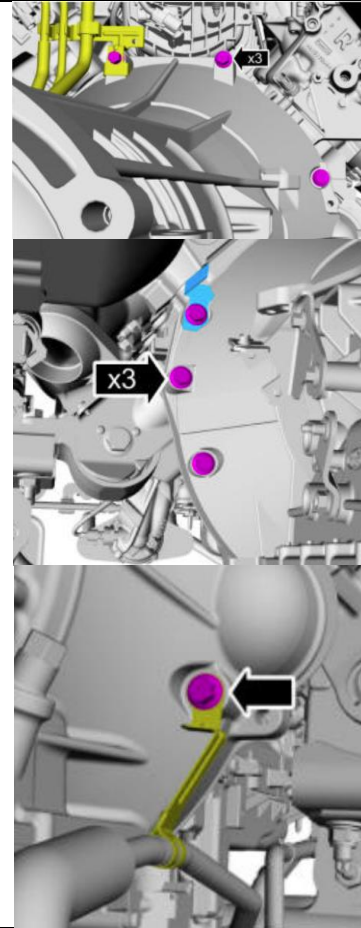

8. Install lower bellhousing bolts.

**Torque: 26 lb.ft (35Nm)**



9. Install torque converter nuts (qty 4).

Then install rubber cover.

**Torque: 30lb.ft (40 Nm)**

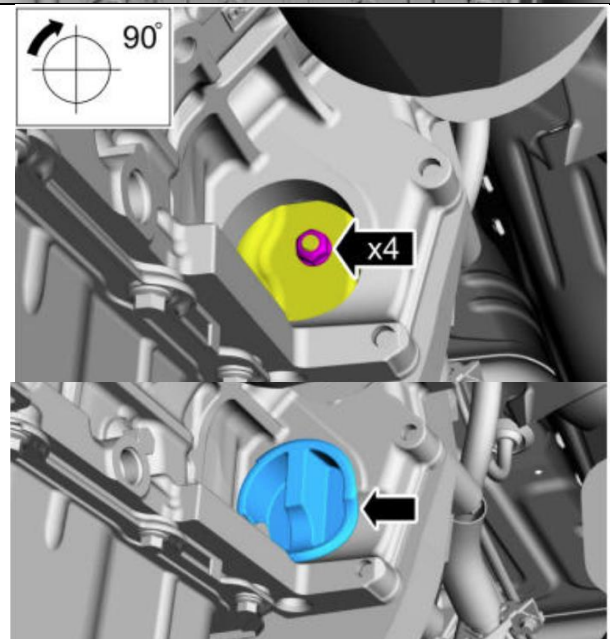

10. Connect and lock the transmission electrical connector.

Attach the wiring harness retainers to transmission.

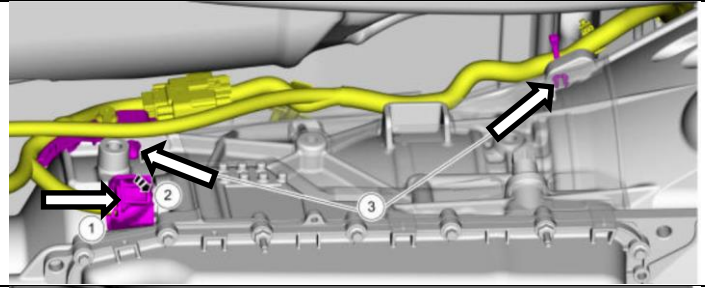

11. Place the fuel line bracket and install the bolt.

**Torque: 26 lb.ft (35Nm)**

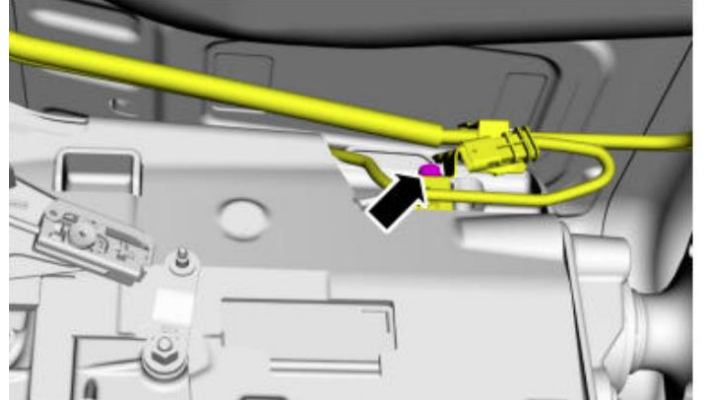

12. Place the fuel line bracket in place, install the bolt, and connect the transfer case vent tube.

**Torque: 26lb.ft (35Nm)**

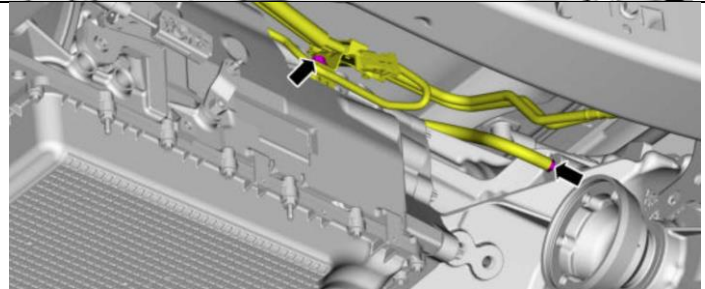

13. Connect the transfer case vent tube and the electrical connector.

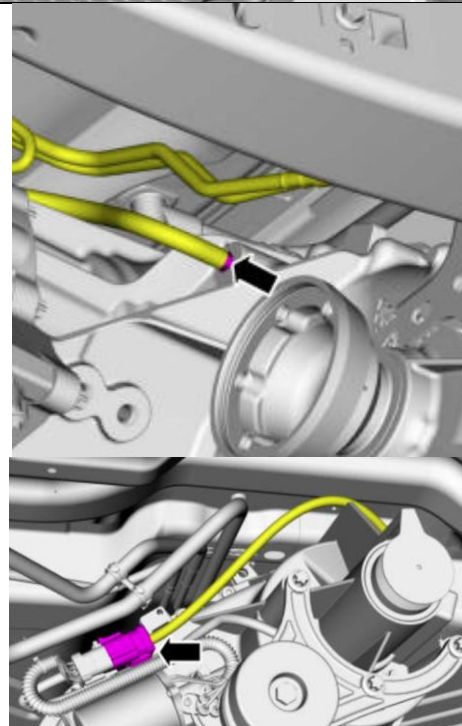

14. Install the selector lever cable bolts but keep the cable disconnected to the manual control lever.

Note:

- If equipped, install the cable splash shield and bolt.

**Torque: 20lb.ft (30Nm) for both**

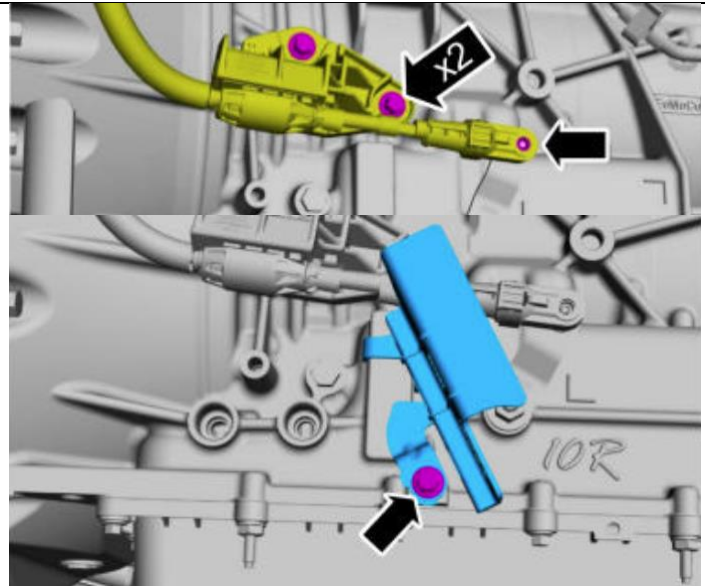

15. Position the RH catalytic converter, and hand tighten it.

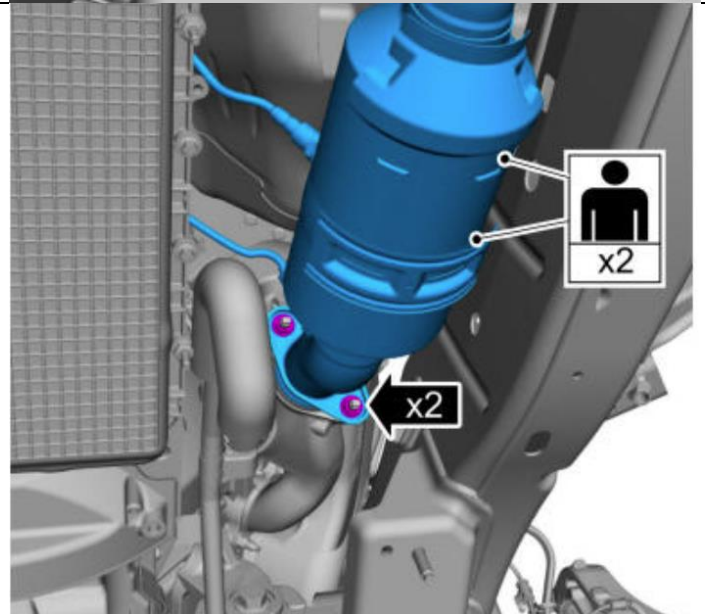

**For 2WD**

16. Put on the transmission support insulator.

Torque bolts in order shown.

**Torque: 76 lb.ft (103Nm)**

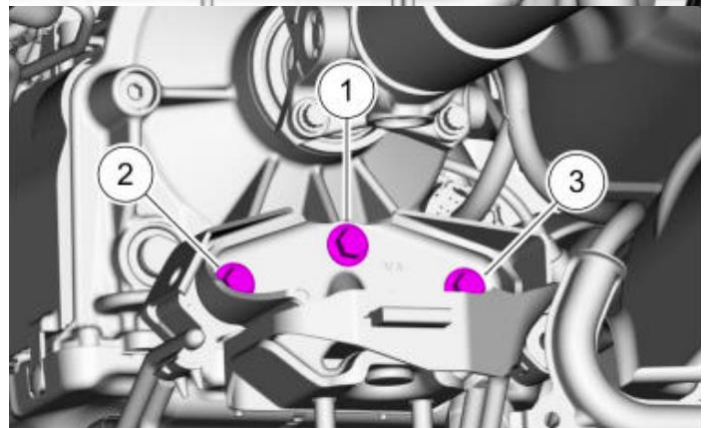
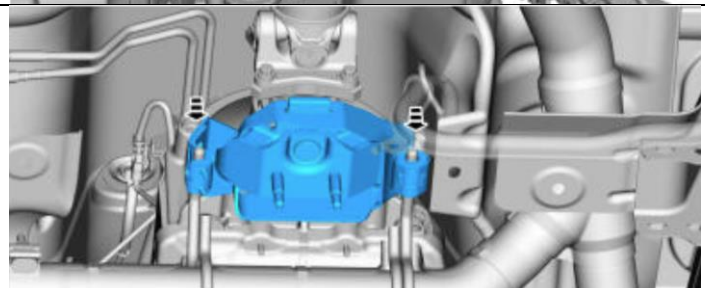

**For 4WD**

17. Install the transmission support insulator.

Torque bolts in order shown.

**Torque: 76 lb.ft (103Nm)**

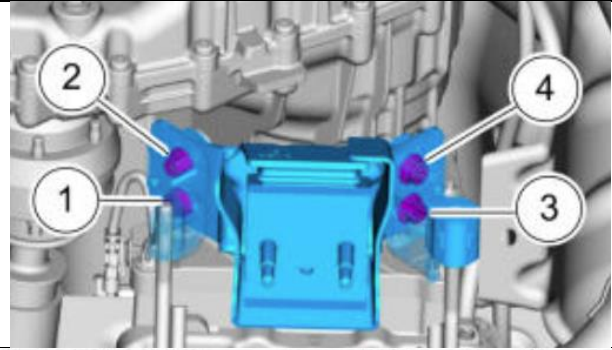

18. Install the LH isolator cap with the bolt.

**Torque: 41 lb.ft (55Nm)**

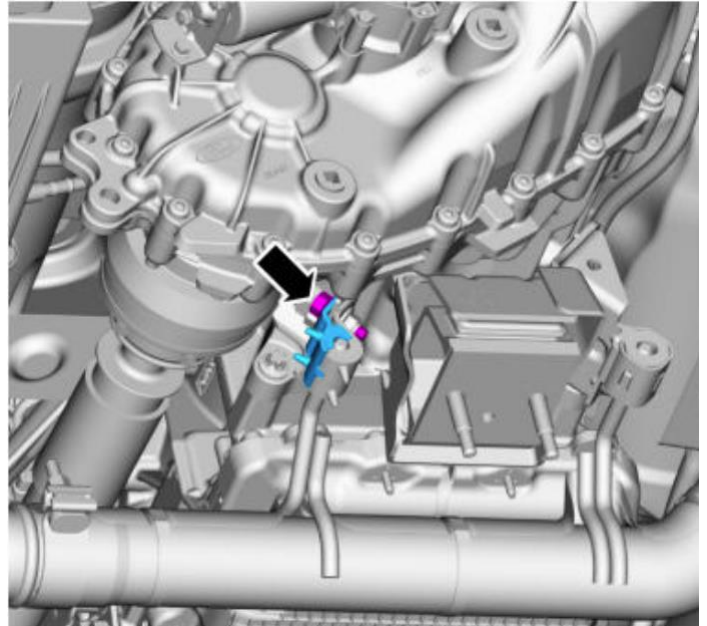

19. Install the transmission support crossmember.

**Torque: 85lb ft (115Nm)**

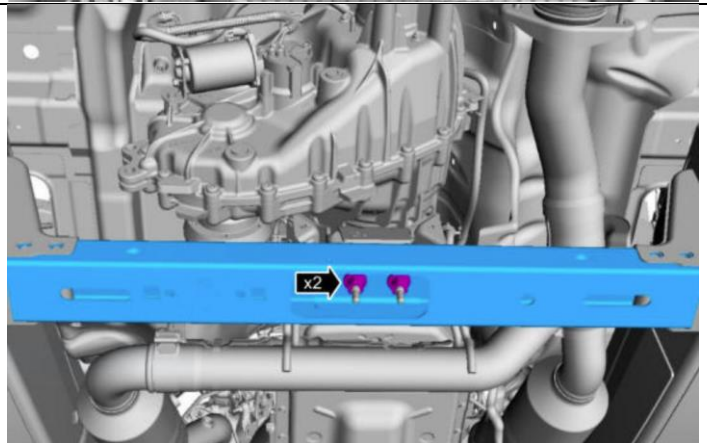

20. Install the transmission support crossmember nuts and bolts.

**Torque: 76 lb ft (103Nm)**

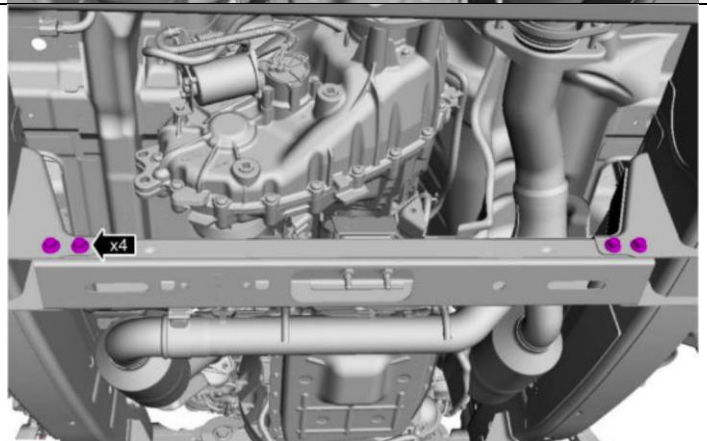

21. Install both LH and RH exhaust heat shield.

**Torque: 177lb.in (20Nm)**

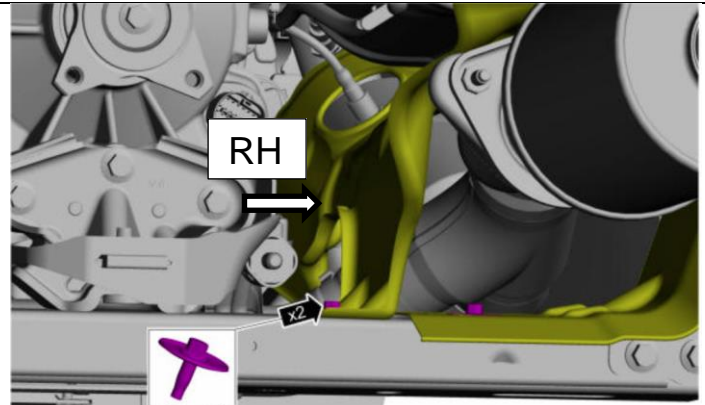

22. If equipped, install the wiring harness onto transmission crossmember.

**Torque: 177in.lb (20Nm)**

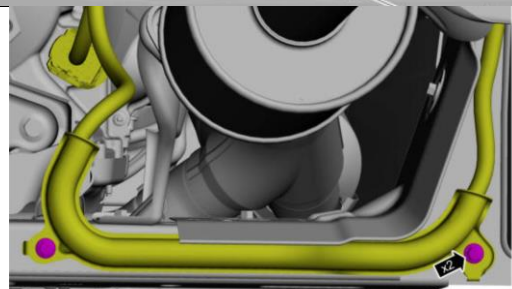

23. Install the skid plate.

**Torque: 177 in.lb (20Nm)**

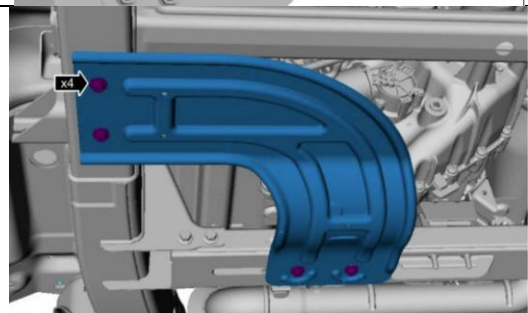

24. Position the LH catalytic converter in vehicle with a new gasket, and tighten the nuts.

**Torque: 30 lb.ft (40Nm)**

Then tighten clamp.

**Torque: 41 lb.ft (55Nm)**

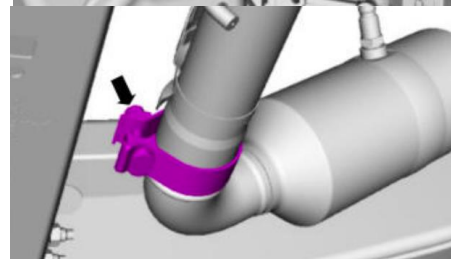
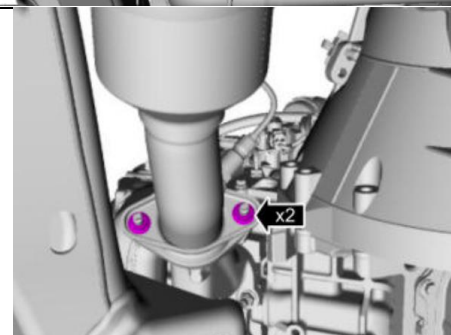

25. Connect both LH and RH HO2S electrical connector.

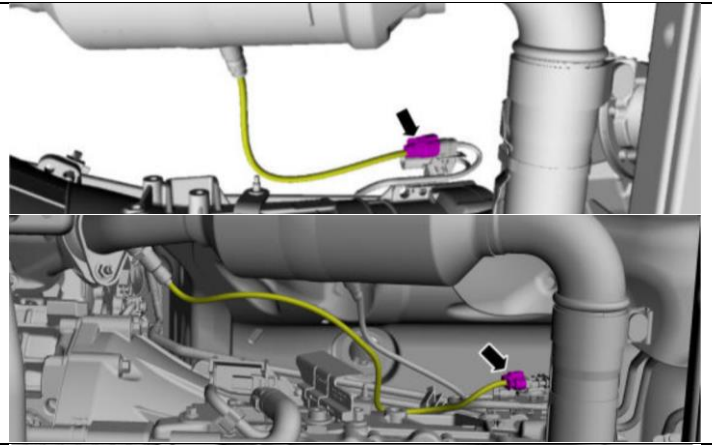

26. Tighten the RH catalytic converter nuts.

Then connect the catalyst monitor sensor.

**Torque: 30 lb.ft (40Nm)**

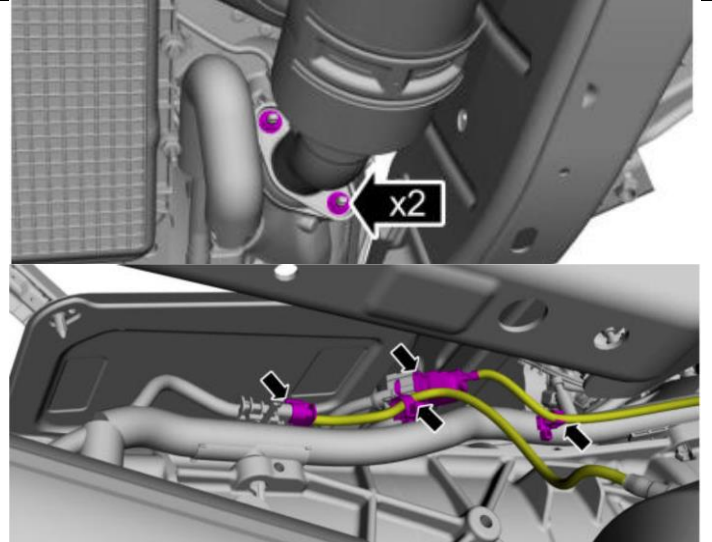

27. Install catalytic converter flange to the muffler inlet pipe bolts.

**Torque: 30 lb.ft (40Nm)**

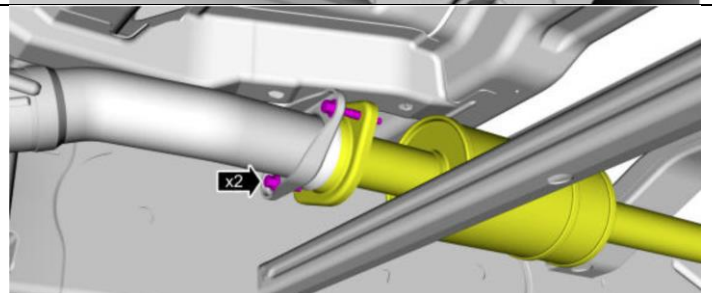

28. Install transmission fluid cooler tubes with the bolt.

**Torque: 22 lb.ft (30Nm)**

Note:

- Inspect the transmission fluid tube backing rings and seals for damage and replace if necessary.

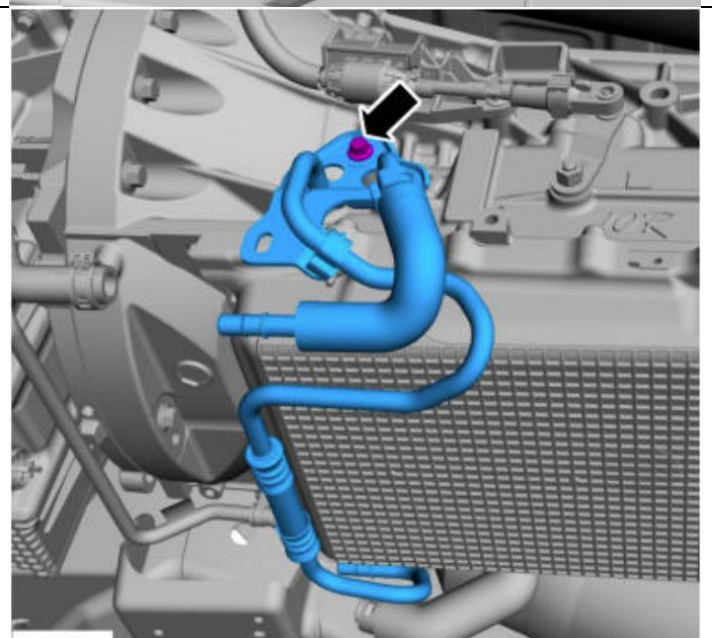

**For 4WD**

29. To install the rear driveshaft, slide the spline into the transfer case.

Next align the index line, and install the 4 bolts.

**Torque: 76lb.ft (103Nm)**

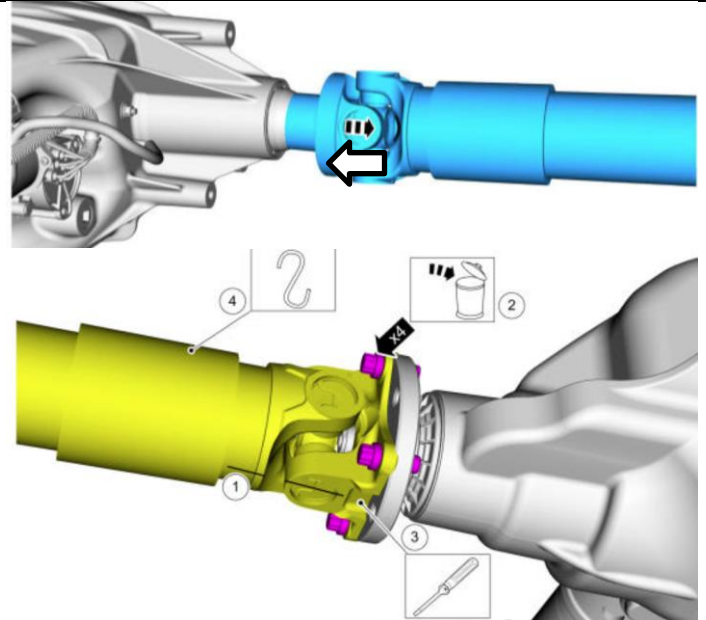

30. If you have a two-piece driveshaft, install the driveshaft carrier bearing bolts.

**Torque: 35lb.ft (48Nm)**

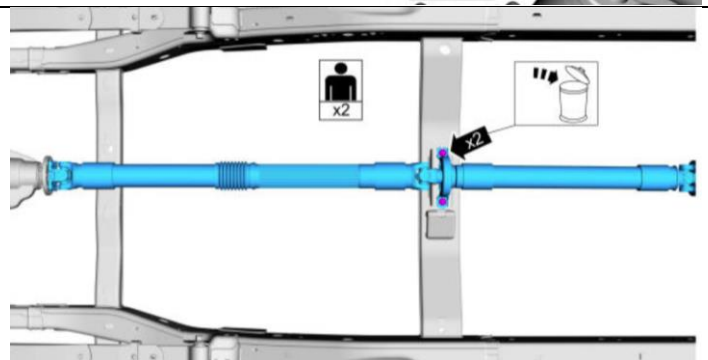
**For 2WD**

31. Align the index line and install the 4 bolts from the driveshaft flange to transmission flange.

**Torque: 76lb.ft (103Nm)**

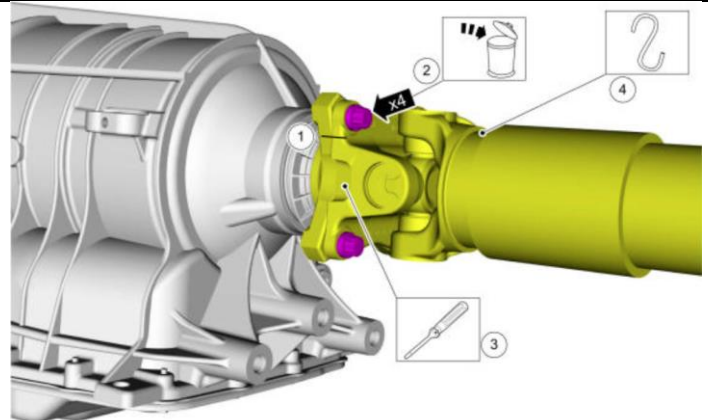

**Steps 32-36 for 4WD**  
**Skip to 37 for 2WD**

32. Install the front driveshaft.

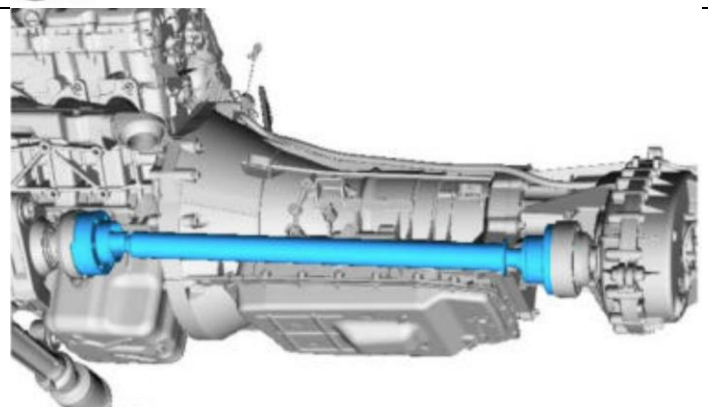

33. Install the rear driveshaft CV joint-to-transfer case flange cup bolts and retaining straps.

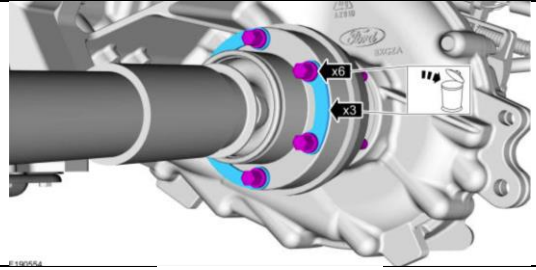

**Torque: 41lb.ft (55Nm)**

34. Ensure to check the fluid level in the transfer case.



35. Ensure to align the index mark and install the front driveshaft CV joint-to-pinion bolts and retaining straps.

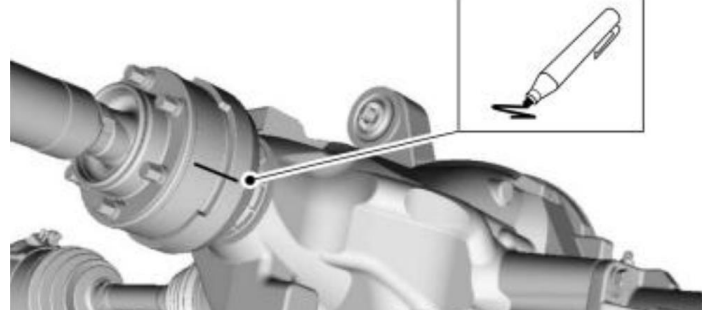

**Torque: 41lb.ft (55Nm)**

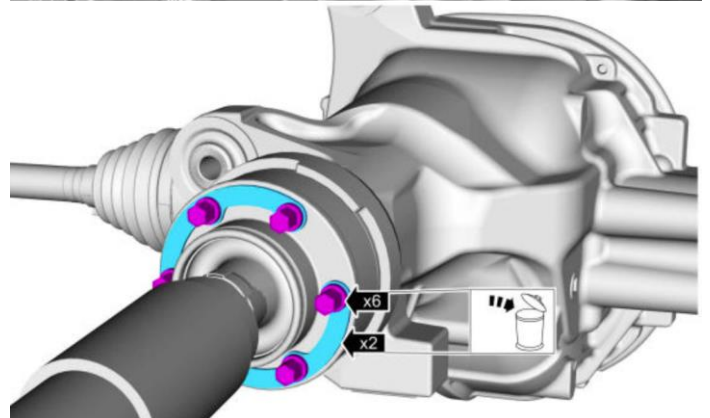

36. Move the stabilizer bar into position and install the bracket nuts.

**Torque: 41lb.ft (55Nm)**

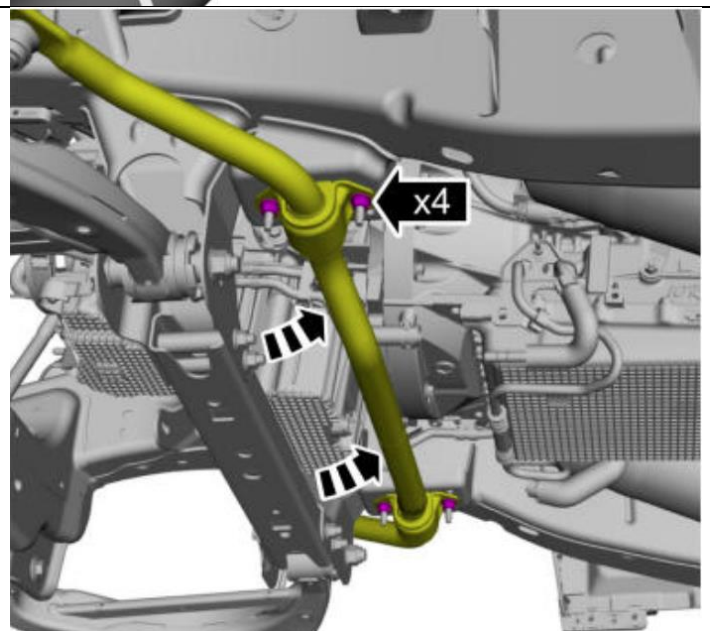

37. Install the transmission fluid cooler with the bolts and the hose clamp.

**Torque: 22 lb.ft (30Nm)**

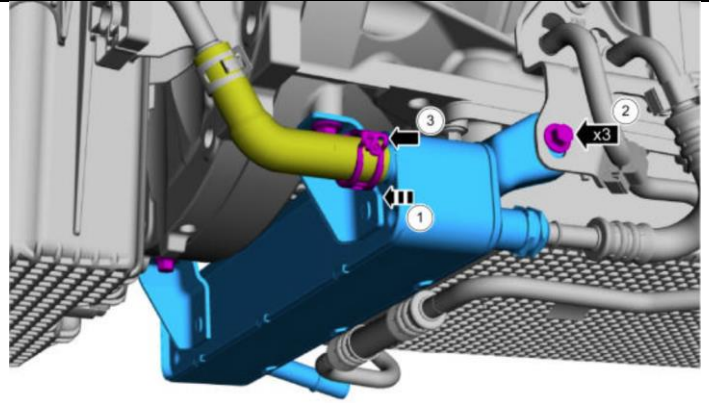

38. Connect the coolant hose to the transmission fluid cooler.

Note:

- Remove tube clamps after hose is connected.

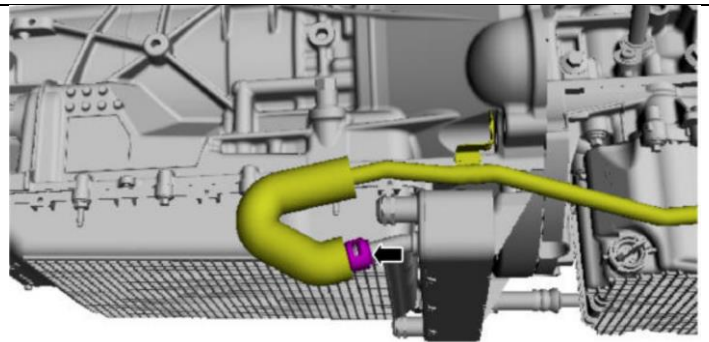

39. (1) Connect the transmission fluid cooler outlet tube and the inlet tube to the transmission fluid cooler.

(2) Install the secondary latch on both inlet and outlet tubes  
Place the heat shields on both inlet and outlet side.

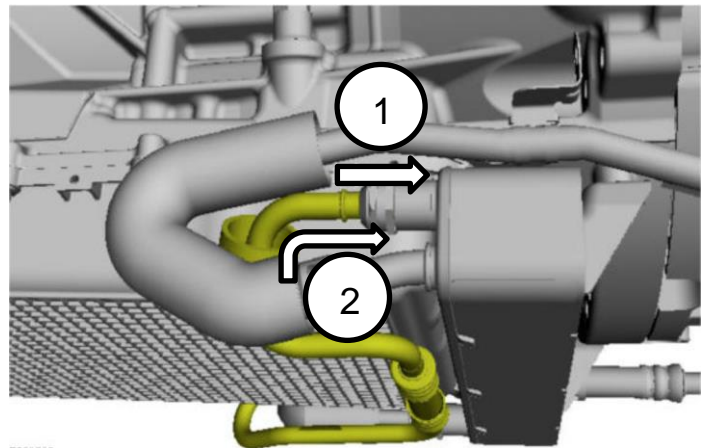

Note:

- Outlet side shown.

40. Install the starter motor with the three bolts.

**Torque: 35lb.ft (48Nm)**

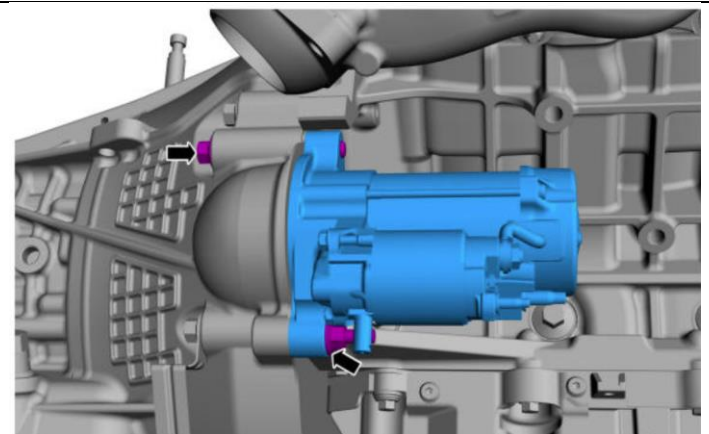

41. (1) Install the starter motor ground cable and secure with nut.

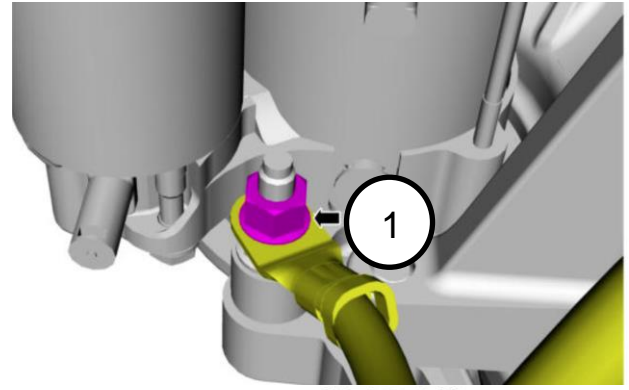

**Torque: 18lb. ft (24Nm)**

- (2) Install the starter motor solenoid control wire and secure with the nut.

**Torque: 53lb.in (6Nm)**

- (3) Install the starter motor solenoid battery cable and secure with nut.

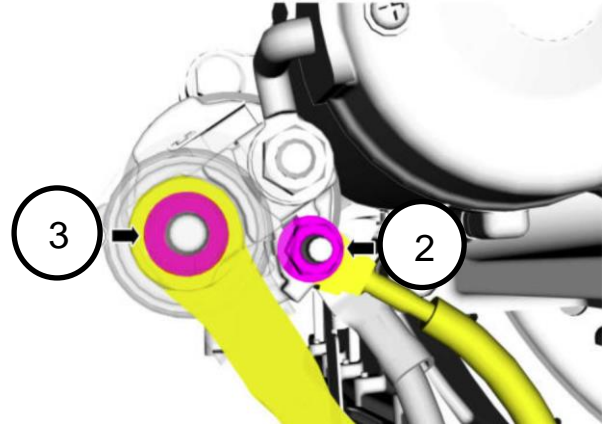

**Torque: 106lb.in (12Nm)**

Close the starter motor solenoid battery cable cover.

42. Install the skid plate and underbody shield.

**Torque: 30lb. ft (40Nm)**

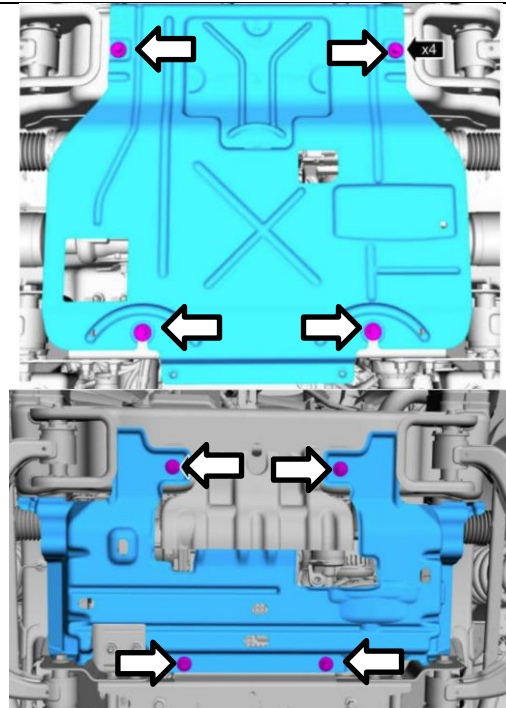

43. Reconnect the battery.

- 44. On a hoist, position the lever in “Drive” position.

Rotate the manual lever (located on the transmission) clockwise until it stops.

Then rotate it counterclockwise 3 positions.



- 45. Connect the selector lever cable to the manual control lever, and lock it on.

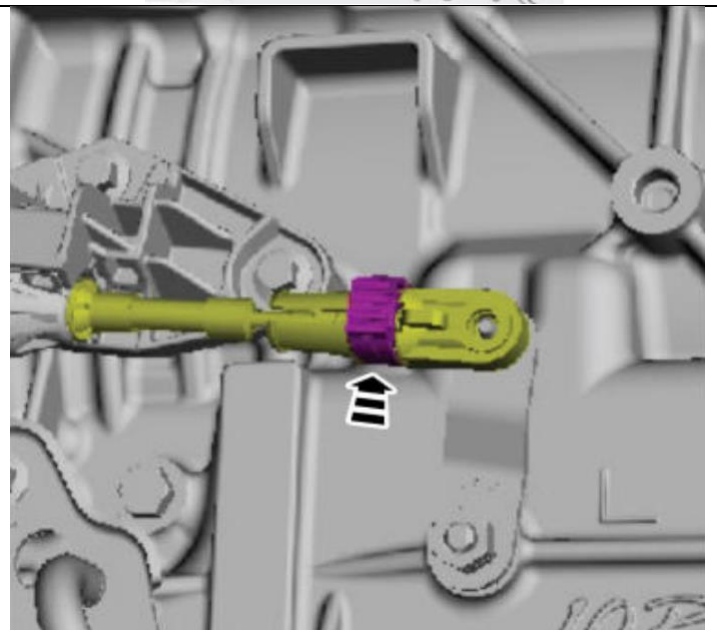

- 46. With the new 12-digit solenoid body identification # (1) and 13-digit solenoid body strategy # (2) and a scan tool, download the correct strategy file and install it as follows.

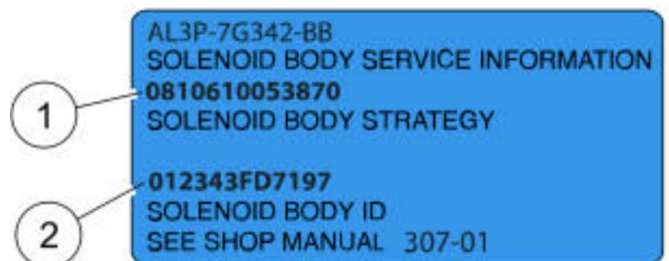

(1) Using the scan tool, navigate to Programming and Programmable Parameters from the toolbox icon and select “transmission”. Follow the

instructions displayed on the scan tool. Enter the 12-digit identification and 13-digit strategy recorded from the solenoid body when prompted.

- (2) Compare the strategy label to the values displayed on the scan tool. The values should match. If they do not, select “update” on the scan tool. The tool will then prompt the user to select an option that describes the repair operation on the transmission. Once selected, the user can enter the transmission code from their label into the tool.
- (3) Enter the 13-digit solenoid body strategy. The tool will verify the numbers are valid and display a message if they are invalid. If the file is present, you may proceed with downloading the file to the module. If not, the scan tool will prompt the user for permission to receive the file from the Professional Technician Society (PTS).
- (4) Follow the instructions on the network to download the strategy file.
- (5) Road test the vehicle following the Adaptive Learning Drive Cycle.

47. Conduct the Adaptive Learning Drive Cycle as follows:

\*Note: Perform the Adaptive Learning drive Cycle on a level surface

- A. Using the scan tool, clear the Diagnostic Trouble Codes and transmission Adaptive Tables
- B. Bring the engine and transmission up to normal operating temperature
- C. Accelerate from a stop with light throttle (15%) and ensure that upshifts between 1<sup>st</sup> and 8<sup>th</sup> gear occur between 1300-1600 RPM
- D. Accelerate with slightly more throttle between 32-38 mph (51-61 k/h) until you reach 55 mph (88km/h) and the 8-9 and 9-10 shifts are complete.
- E. Brake gently to a complete stop and hold the brake pedal for five (5) seconds.
- F. Shift into neutral. Wait 1 second.
- G. Shift into Reverse. Wait 2 seconds
- H. Shift into Neutral. Wait 1 second.

I. Shift into Drive. Wait 2 seconds.

J. Repeat steps C through I six additional times

48.

49. As some coolant will have been lost during the transmission replacement, top up the engine coolant degas bottle as needed and reinstall the cap.

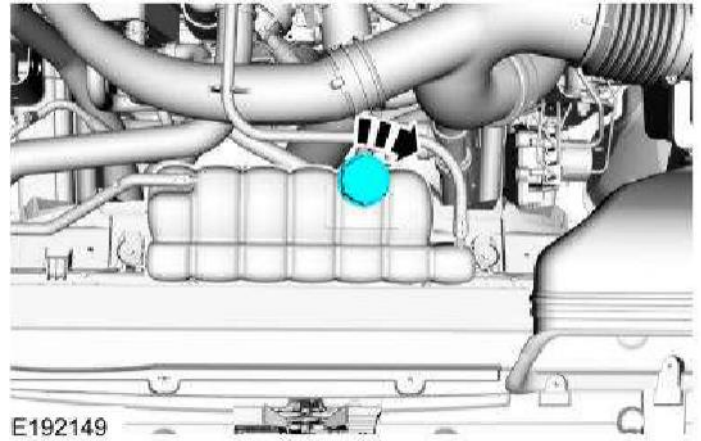

50. Remove transmission fill plug and remove the fluid level indicator from the plug.

**Note** There are two styles of level indicators, one with numbers and one with A/B region.

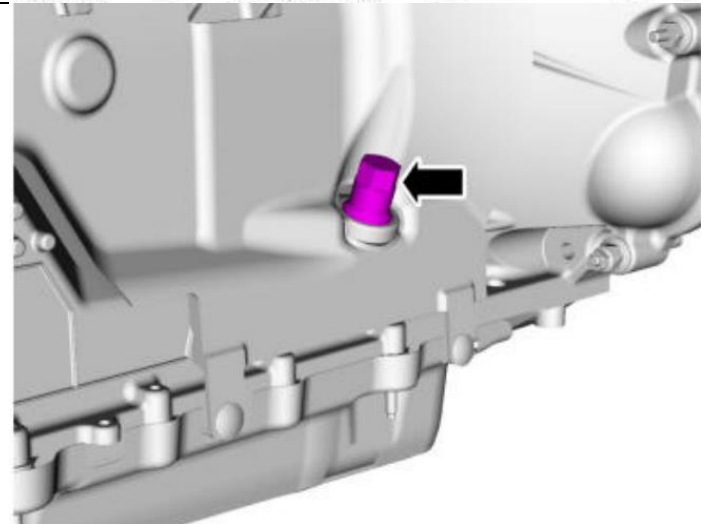

51. Fill the transmission with Ford Mercon ULV fluid (Part number XT-12-QULV).

Fill only until the fluid level indicator shows at the bottom of the B range or at number 6. This is the COLD fill range.

Initial fill will be approx. 7 quarts.

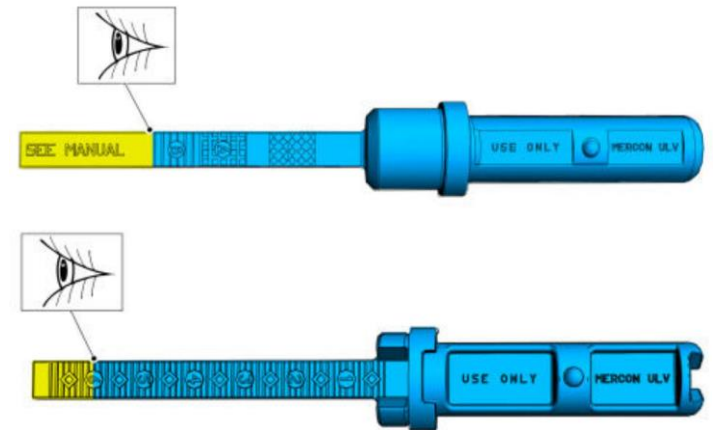

52. Turn the engine on, place the gear selector in each position for about 5 seconds. Confirm the fluid level is still in the correct range with the engine running and transmission in park. Reinstall fill plug.

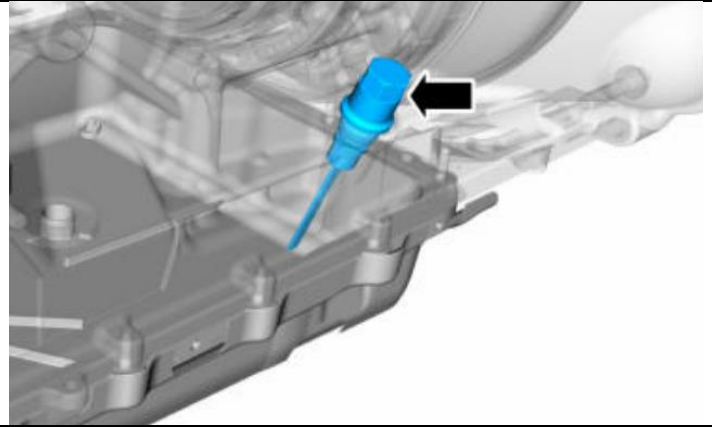

53. Use diagnostic scan tool (or instrument cluster) to monitor transmission fluid temperature. Drive the vehicle until the fluid has reached 96°C-101°C (206°F-215°F). Place vehicle in PARK and allow engine to idle. Check fluid again.

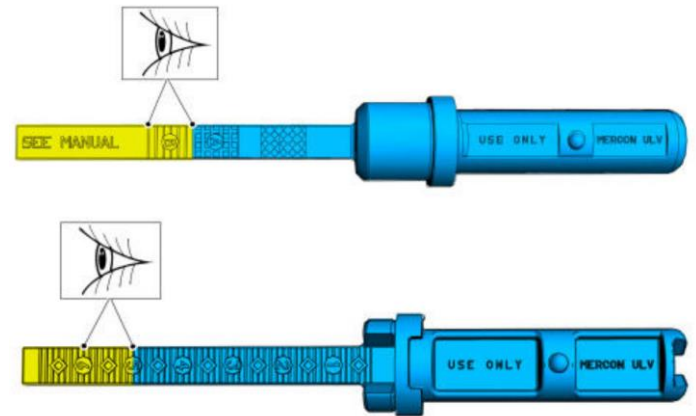

Fluid level should be in the B range or between 5 and 6. This is the HOT fill range.

54. Check the engine coolant level again to ensure the level is correct and any trapped air has escaped.

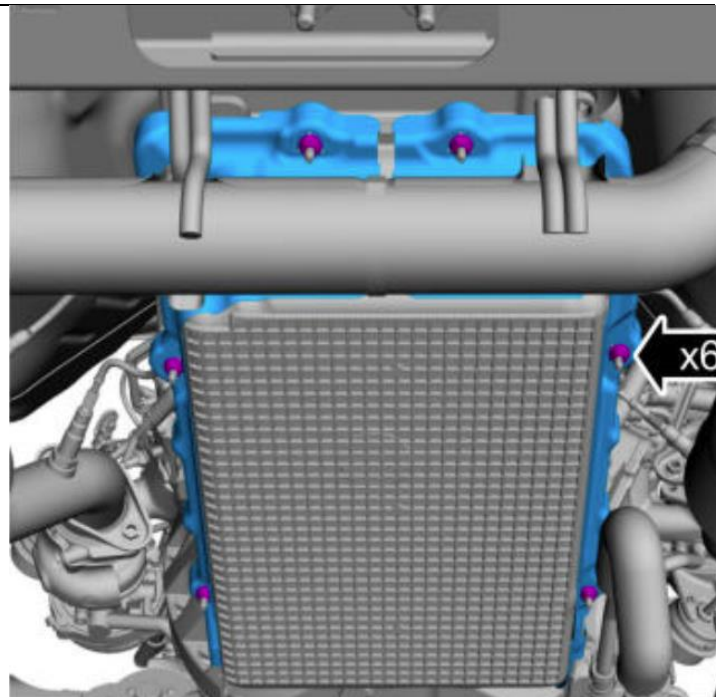

55. Install the oil pan heat shields.

**Torque: 80lb.in (9Nm)**

56. Install the splash shield.

**Torque: 71lb.in (8Nm)**

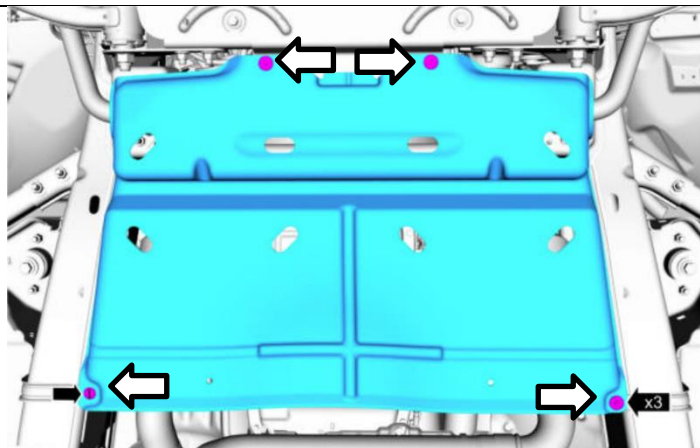

## Line Pressure Checks

With upgrades done to the valvebody, we want to make sure that your transmission is functioning properly. To check your mainline pressure, connect a gauge to the pressure port on the side of the transmission

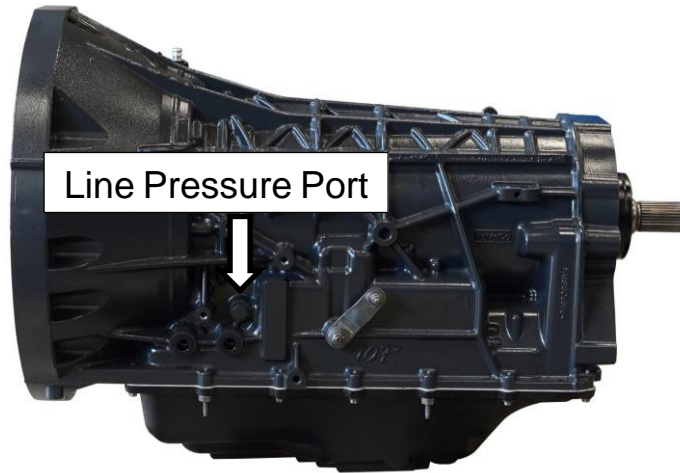

The line pressure service port plug thread is M10x1.00.

(Psi) +/-15psi	OEM 10R80		BD 10R80 RoadMaster	
	No Throttle	WOT	No Throttle	WOT
Park	90	-	120	-
Neutral	90	-	120	-
Reverse	90	-	120	-
1	65	230	110	260
2	65	165	110	200
3	65	230	110	260
4	65	130	110	180
5	75	140	120	180
6	75	140	120	180
7	75	230	120	260
8	75	140	120	230
9	75	150	120	180
10	70	150	120	180