

7929 Lincoln Ave. Riverside, CA 92504
 Phone: 951.689.ICON | Fax: 951.689.1016

PART #	DESCRIPTION
95000	10-14 RAPTOR FRONT 3.0 VS COILOVER RR CDCV SHOCKS

COMPONENTS INCLUDED	
(2) 194961L 10-14 RAPTOR FRONT 3.0 CO (2) 95000H 10-14 RAPTOR CO HARDWARE KIT	(1) 194507 10-20 RAPTOR RESI MOUNT (DRVR) (1) 194508 10-20 RAPTOR RESI MOUNT (PASS)
HARDWARE INCLUDED	
95000H HARDWARE KIT	
(1) 197011 RAPTOR LCA ADAPTER (1) 197013 RAPTOR LCA ADAPTER (NARROW) (3) 605101 3/8-16 X 1.00 BOLT (3) 605131 3/8 SPLIT LOCK WASHER	(1) 605500 5/8-11 X 5.00 BOLT (1) 605520 5/8-11 NYLOCK NUT (2) 605530 5/8" FLAT WASHER (2) 605931 STAINLESS STEEL HOSE CLAMPS
TOOLS REQUIRED	
JACK JACK STANDS GRINDER W/ BARREL SANDER TORQUE WRENCH HAMMER	5/16" NUT DRIVER 9/16" SOCKET / WRENCH 15/16" SOCKET / WRENCH 15MM SOCKET / WRENCH 21MM SOCKET / WRENCH 30MM SOCKET / WRENCH
TECH NOTES	
<p>1. YOUR ICON COILOVER ASSEMBLIES COME FACTORY CHARGED TO 150 PSI. RELEASING NITROGEN PRESSURE MAY LEAD TO SHOCK MALFUNCTION AND REDUCED RIDE QUALITY. FAILURE CAUSED BY LOW NITROGEN PRESSURE IS NOT COVERED UNDER ICON'S WARRANTY POLICY.</p> <p>2. YOUR ICON COILOVER ASSEMBLIES COME SHIPPED AT ICON'S RECOMMENDED RIDE HEIGHT. REDUCING DROOP TRAVEL WILL REDUCE RIDE QUALITY. DO NOT PRELOAD THE COIL BEYOND 1.375" OF EXPOSED THREADS BETWEEN THE BOTTOM OF THE TOP CAP AND THE TOP OF THE COIL ADJUSTER NUT. ADJUSTING PRELOAD BEYOND THIS SETTING WILL CAUSE THE COIL TO BIND AND DAMAGE WILL OCCUR TO COILOVER AND/OR VEHICLE.</p>	



WARNING!
<p>** READ ALL INSTRUCTIONS THOROUGHLY FROM START TO FINISH BEFORE BEGINNING INSTALLATION! IF THESE INSTRUCTIONS ARE NOT PROPERLY FOLLOWED SEVERE FRAME, SUSPENSION AND TIRE DAMAGE MAY RESULT TO THE VEHICLE!</p> <p>** ICON VEHICLE DYNAMICS RECOMMENDS THAT YOU EXERCISE EXTREME CAUTION WHEN WORKING UNDER A VEHICLE THAT IS SUPPORTED WITH JACK STANDS.</p> <p>** ICON VEHICLE DYNAMICS RECOMMENDS ALL INSTALLATION TO BE PERFORMED BY A PROFESSIONAL SHOP/SERVICE TECHNICIAN. PRODUCT FAILURE CAUSED BY IMPROPER INSTALLATION WILL NOT BE COVERED UNDER ICON'S WARRANTY POLICY.</p>

INSTALLATION

1. Ensure truck is in gear or in park, set parking brake, turn off engine, and chock tires.
2. With the vehicle sitting on level ground, measure from the center of the wheel hub to the top of the fender opening. Record this measurement, you will refer to it later to set the ride height.
3. Using a properly rated jack, raise the front of the vehicle and support the frame rails with jack stands. Ensure the jack stands are secure and set properly before lowering the jack. NEVER WORK UNDER AN UNSUPPORTED VEHICLE. Remove the front wheels.
4. Disconnect the outer tie rod end on both sides: Loosen the nut a few turns, strike the end of the steering knuckle with a large hammer to dislodge the taper. Remove the nut and swing the tie rod out of the way. Take care to not damage the threads on the tie rod end. [FIGURE 1 & 2]

FIG.1



FIG.2

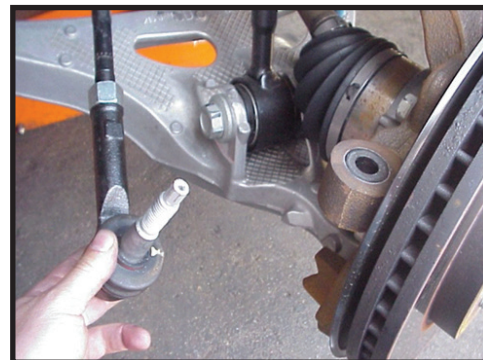

5. Remove the (3) nuts securing the upper coil seat to the frame perch. Do not loosen or remove the larger center nut securing the spring seat to the shock shaft. This will result in the stock coil assembly coming apart violently, causing damage to components and possible injury.
6. Remove the bolt holding the lower shock eyelet to the lower control arm.

7. Remove the stock coilover assembly. Due to rubber bushing stiffness you may need to pull down on the suspension. To make this easier, remove the upper control arm by loosening the UCA nut from the spindle and breaking the taper loose, freeing the upper control arm from the knuckle. Be careful not to damage any brake lines or wires that may be routed down the arm. [FIGURE 3 & 4]

FIG.3

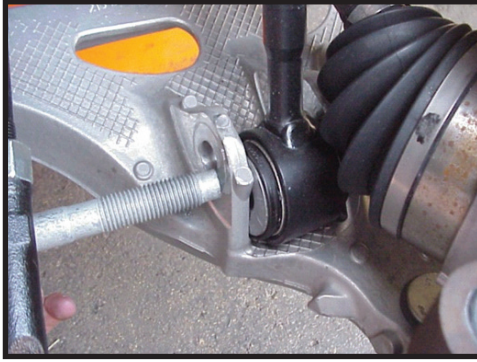
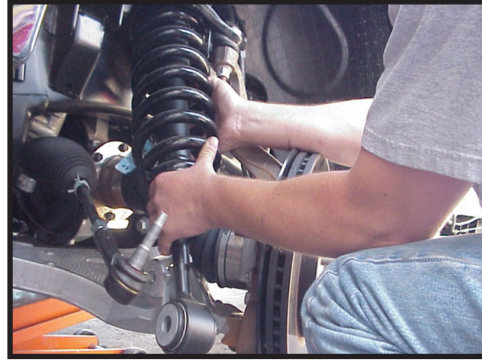

FIG.4



8. Before installing the new ICON coilover, the stock coil bucket will need to be trimmed to allow for clearance of the large hose attaching the remote reservoir and compression adjuster. Use the examples to lightly trim the edge to allow the fittings to pass through the bucket. [FIGURE 5 & 6]

FIG.5

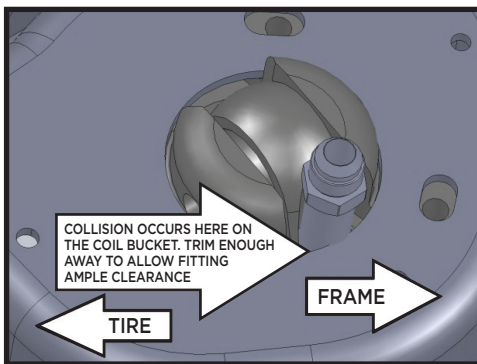
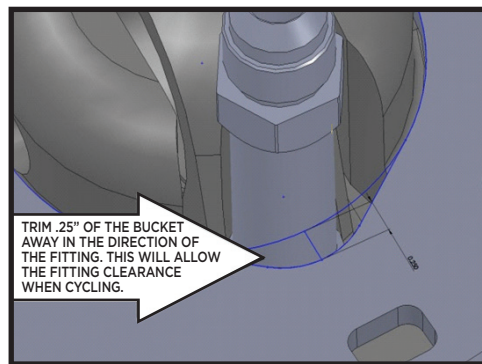

FIG.6



9. Once the shock bucket has been trimmed, install the coilover assembly by guiding the remote reservoir through the hole in the bucket and route the reservoir towards the front of the chassis.

10. Install the upper mount using (3) 3/8" x 1.00" bolts and (3) lock washers. Do not reuse old coilover hat.

11. Install lower shock mount to the lower control arm: First, install the adapter slugs into the lower mount from the inside out. The spacers are designed to space the shock as far forward as possible (away from the axle). Cut the zip tie off of the lower shock eye and make sure that the spacers do not fall out. Slide the lower end of the shock between the adapter slugs and install the supplied lower 5/8" bolt with washers. [Torque to 120 ft-lbs] [FIGURE 7 & 8]

FIG.7

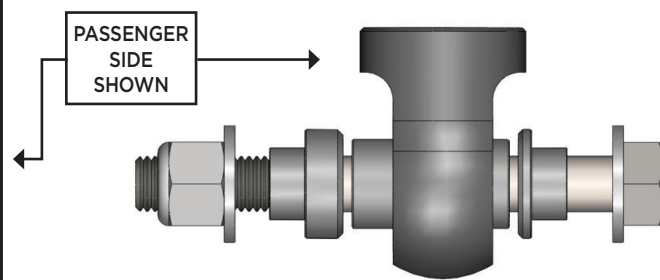

FIG.8

12. Reinstall the outer tie rod end. [Torque to 54 ft-lbs] Install cotter pin.

13. Route the reservoir hose in a safe manner putting the reservoir at the front of the coil bucket. Using the upper control arm bolt, slide the reservoir mounting bracket onto the chassis. The reservoir bracket is mounted underneath the nut of the front upper control arm bolt. Remove the nut from the control arm bolt, slide the bracket over the bolt and up against the coil bucket. The passenger side also requires that you remove the ground strap and reinstall it through the reservoir bracket. [Torque control arm nut to factory spec] Use hose clamps to attach the reservoir to the bracket. Do not overtighten hose clamps. [FIGURE 9 & 10]

FIG.9

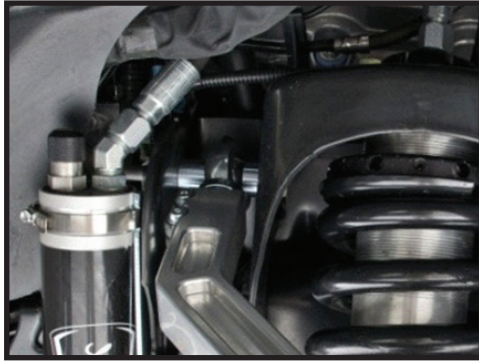
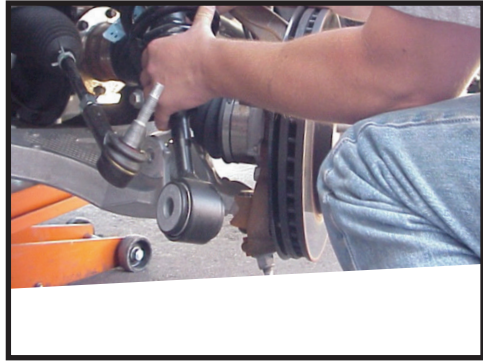

FIG.10



14. Reinstall the wheels and lower the vehicle back to the ground. Roll the vehicle back and forth a couple of feet and bounce the front end to allow the suspension to settle to its new ride height. Remeasure from the wheel hub center to top of fender opening, compare to measurements in step 2 to see the actual lift height gained. Adjust coilover preload as necessary then have the vehicle professionally aligned.

VERIFY ALL FASTENERS ARE PROPERLY TORQUED BEFORE DRIVING VEHICLE.

RETORQUE ALL NUTS, BOLTS AND LUGS AFTER 100 MILES AND PERIODICALLY THEREAFTER.

3.0 VS SERIES SHOCK & COILOVER TECHNICAL INFORMATION

MAINTENANCE

ICON shock absorbers are a high quality rebuildable race style shock absorber designed for optimal performance. With a unit of this caliber on your vehicle, routine maintenance is required to keep them looking and operating in like new condition. Residual oil and assembly lube may be present at all seal paths from the factory out of the box and is considered normal. Pooling of oil however is not acceptable at any time and one should contact the ICON dealer where purchased.

BELOW ARE GUIDELINES BASED ON HOW YOU USE YOUR VEHICLE BUT YOUR MILEAGE MAY VARY:

STREET USE:

- Send in for factory servicing every 40,000 miles or if a leak develops, ride quality decreases, or they begin to make excessive noise.
- Remove any buildup of road salt, mud, or debris from shocks and coil springs anytime accrued
- Clean with mild soap and water with each oil change or anytime you notice build up.
- Wax the cylinders yearly with automotive wax to prevent corrosion.
- Check nitrogen pressure yearly. (252004 charge needle assembly available at any ICON distributor)
- Check bearings for excessive wear yearly.
- DO NOT apply any type of lube to the upper and lower bearings.

STREET/DIRT:

- Send in for factory servicing every 15,000 miles or if a leak develops, ride quality decreases, or they begin to make excessive noise.
- Clean with mild soap and water with each oil change, offroad trip, or anytime you notice build up.
- Wax the cylinders yearly with automotive wax to prevent corrosion.
- Check nitrogen pressure each dirt outing. (252004 charge needle assembly available at any ICON distributor)
- Check bearings for excessive wear yearly.
- DO NOT apply any type of lube to the upper and lower bearings.

DIRT USE:

- Send in for factory servicing every 1,000 miles.
- Check nitrogen pressure each outing. (252004 charge needle assembly available at any ICON distributor)
- Remove any buildup of mud or debris from shocks and coil springs after every outing.

SELF-SERVICE:

- Contact ICON for service kits & tools at (951) 689-4266.

PRODUCT REGISTRATION

Please visit: <http://www.iconvehicledynamics.com/tech-support/registration/> to register your product.

ICON VEHICLE DYNAMICS SHOCK ABSORBER WARRANTY

This shock absorber has a 1 year warranty against any manufacturer's defects. If a shock fails within the initial year of ownership, the shock must be shipped to ICON Vehicle Dynamics for inspection and service. If a shock is inspected and it has been determined the shock failed due to neglect, damage caused by improper installation or any other reason besides "normal wear and tear", the owner of said shock is responsible for all service costs. This includes labor, parts, and shipping.

ICON Vehicle Dynamics warrants to the original retail purchaser who owns the vehicle on which the product was originally installed. ICON Vehicle Dynamics does not warrant the product for finish, alterations, modifications and/or installation contrary to ICON Vehicle Dynamics instructions. ICON Vehicle Dynamics products are not designed, nor are they intended to be installed on vehicles used in race applications, for racing purposes or for similar activities. (A "race" is defined as any contest between two or more vehicles, or a contest of one or more vehicles against the clock, whether or not such contest is for a prize). This warranty does not include coverage for police or taxi vehicles, race vehicles, or vehicles used for government or commercial purposes. Also excluded from this warranty are sales outside of the United States of America and Canada.

ICON Vehicle Dynamics' obligation under this warranty is limited to the repair or replacement, at ICON Vehicle Dynamics' discretion, of the defective product. Any and all costs of removal, installation or re-installation, freight charges and incidental or consequential damages are expressly excluded from this warranty. Items that are subject to wear are not considered defective when worn and are not covered.

ICON Vehicle Dynamics components must be installed as a complete kit as shown in our current application guide. Any substitutions or exemptions of required components will immediately void the warranty. Some finish damage may happen to parts during shipping and is not covered under warranty.

This warranty is expressly in lieu of all other warranties expressed or implied. This warranty shall not apply to any product that has been improperly installed, modified or customized subject to accident, negligence, abuse or misuse.

To send a shock in for warranty please visit our website <http://www.iconvehicledynamics.com/tech-support/shock-service/>



ICON VEHICLE DYNAMICS®
PERFORMANCE SUSPENSION SYSTEMS AND SHOCK ABSORBERS

7929 Lincoln Ave. Riverside, CA 92504 Phone: 951.689.ICON Fax: 951.689.1016
www.iconvehicledynamics.com



FOLLOW US ON FACEBOOK!



7929 Lincoln Ave. Riverside, CA 92504
Phone: 951.689.ICON Fax: 951.689.1016

PART #	DESCRIPTION
95120	2010-2014 RAPTOR HYDRAULIC REAR BUMP STOP SYSTEM

COMPONENTS INCLUDED	
(2) 204907 BUMPSTOP ASSEMBLY (1) 194005 BUMPSTOP MOUNT (DRVR) (1) 194006 BUMPSTOP MOUNT (PASS) (1) 194008 INSIDE BUMPSTOP MOUNT (DRVR) (1) 194009 INSIDE BUMPSTOP MOUNT (PASS) (1) 197015 BILLET CROSSMEMBER	(2) 194010 STRIKER PLATE (2) 194011 NUT PLATE (2) 190006 CROSSMEMBER MID PLATE (2) 197016 TENSION ROD (2) 190005 TENSION ROD STRUT TAB (1) 95120H HARDWARE KIT
HARDWARE INCLUDED	
95120H HARDWARE KIT	
BAG 1	
(1) 605108 3/8-16 X 1.250 BOLT (1) 605133 3/8 FLAT WASHER (12) 605302 1/2-13 X 1.500 BOLT (4) 605322 1/2-13 C-LOCK NUT (26) 605330 1/2 FLAT WASHER	(1) 605125S 3/8-16 U-NUT (4) 605301 1/2-13 X 1.250 BOLT (6) 605321 1/2-13 NYLOCK NUT (2) 605333 1/2-130 FLANGED NYLOCK NUT
BAG 2	
(2) 295523 LEFT-HAND ROD END (2) 295524 1/2-20 CLEVIS (2) 605108 3/8-16 X 1.250 BOLT (2) 605121 3/8-16 NYLOCK NUT (4) 605133 3/8 FLAT WASHER	(7) 605307 1/2-13 X 2.750 BOLT (7) 605321 1/2-13 NYLOCK NUT (17) 605330 1/2 FLAT WASHER (2) 605355 1/2-20 JAM NUT (2) 605356 1/2-20 LEFT HAND JAM NUT
BAG 3	
(2) 209003 SLEEVE 2.25 X 2.010 X 1.00 (4) 605052 1/4-20 NYLOCK NUT (4) 605057 1/4-20 X 2.000 BOLT	(4) 605121 3/8-16 NYLOCK NUT (4) 605133 3/8 FLAT WASHER (2) 605149 3/8-16 U-BOLT (2) 605970 VIBRATITE ANTISEIZE TUBE
TOOLS REQUIRED	
FLOOR JACK JACK STANDS LARGE FLAT BLADE SCREWDRIVER 9/16" SOCKET / WRENCH 3/4" SOCKET / WRENCH	7/16" SOCKET / WRENCH 10MM SOCKET / WRENCH 13MM SOCKET / WRENCH 21MM SOCKET / WRENCH PANEL POPPER (OPTIONAL)
TECH NOTES	
1. YOUR ICON BUMP STOP ASSEMBLIES COME FACTORY CHARGED TO 150 PSI. PLEASE CONSULT ICON PRIOR TO MAKING ANY NITROGEN PRESSURE CHANGES.	



WARNING!
<p>** READ ALL INSTRUCTIONS THOROUGHLY FROM START TO FINISH BEFORE BEGINNING INSTALLATION! IF THESE INSTRUCTIONS ARE NOT PROPERLY FOLLOWED SEVERE FRAME, SUSPENSION AND TIRE DAMAGE MAY RESULT TO THE VEHICLE!</p> <p>** ICON VEHICLE DYNAMICS RECOMMENDS THAT YOU EXERCISE EXTREME CAUTION WHEN WORKING UNDER A VEHICLE THAT IS SUPPORTED WITH JACK STANDS.</p> <p>** ICON VEHICLE DYNAMICS RECOMMENDS ALL INSTALLTION TO BE PERFORMED BY A PROFESSIONAL SHOP/SERVICE TECHNICIAN. PRODUCT FAILURE CAUSED BY IMPROPER INSTALLATION WILL NOT BE COVERED UNDER ICON'S WARRANTY POLICY.</p>

INSTALLATION

1. Remove the spare tire from underneath bed per owner's manual instructions. This is best done on the ground before jacking up the vehicle.
2. Using a properly rated jack, raise the rear of the vehicle and support on jack stands under the frame rail. Remove tires and slowly droop the suspension.
3. Remove the factory bump stops. The rubber bumpstop snaps in, to remove it twist and firmly pull out. Remove the bolt and bump cup. Save the bolt as it will be reused later. [FIGURE 1]

FIG.1



FIG.2



4. Move brake line bracket and wire harness on driver's side. Remove the bolt holding the brake line bracket to the inside of the frame and set aside for reinstallation later. Using a panel clip tool (or a large flat screwdriver) pop the plastic retaining clips out of the inside frame rail. Remove all clips 10" forward and 20" rearward of the bump stop on the driver's side frame rail. You can now flex the lines and harness away from the inside of the frame. [FIGURE 2]

5. Move the exhaust on the passenger's side. Remove the (2) bolts from the rear exhaust hanger and (1) bolt from the hanger on the crossmember just forward of the axle. Slide the hangers off the support rod of the exhaust. Set aside for reinstallation later.

6. Insert the supplied retainer nut clip in passenger side frame rail (Hardware Bag 1). [FIGURE 3]

FIG.3



FIG.4

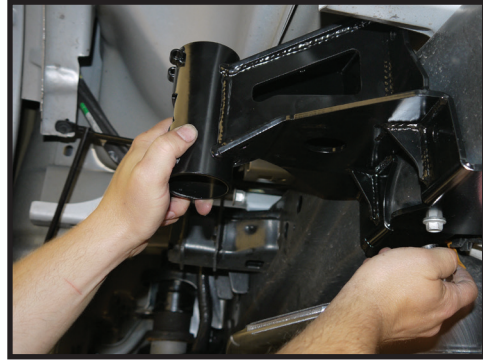

7. Inspect the frame, some factory welds may protrude above the frame surface. For ideal fitment, sand the welds so the surfaces mate well. When installing the bracketry system, it is best to leave the hardware loose until all of hardware is started to assist in alignment. Raptors that have been driven hard off-road often experience some degree of frame damage just above the factory bump stop. This bump system can tolerate some frame distortion and still install well and align correctly, but it may be necessary to leave some hardware very loose or slowly tighten hardware to pull the bracketry into place.

NOTE: If significant sanding is required, spray paint is recommended to prevent frame corrosion.

8. Refer to Diagram 1 for correct bolt location and direction. [DIA.1]

9. Position the outer bumpstop brackets (See DIA.2, #2, #3 & #4) on the frame. Install the factory bump stop bolt through the center bottom hole of the bracket into the frame. Do not tighten. [FIGURE 4]

FIG.4

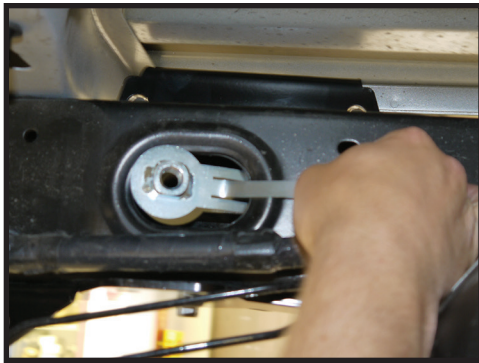

FIG.5



10. Position the nut plate (See DIA.2, #2 & #8) on the inside of the frame. With the arrow pointing toward the front of the truck, pass the long end of the nut plate through pocket on the inside of the frame. Holding the handle, rotate the rest of the nut plate into the frame and position behind the oval holes in the frame. Install (2) 1/2" x 1.5" bolts with washers through bracket into nut plate. Do not tighten yet. [FIGURE 5]

11. Install driver side inner bracket (SEE DIA.2, #2 & #5). Starting rearward of the bed crossmember behind the axle, pass the crossmember portion of the bracket up behind and rotate over the top of the wire and brake line harness. Move the bracket forward and into position. Install (2) 1/2" x 1.5" bolts and washers in the upper holes joining the inner and outer brackets. The front upper uses a washer and a nylock nut. The rearward upper nut is more difficult to get to. Using the flanged nylock nut, place the nut in the socket with an extension to reach in-between the bracket and bed. Install (2) 1/2" x 1.25" bolts, washers, and C-lock nuts in the lower front and lower rear holes with the nuts facing toward the outside of the vehicle. [FIGURE 6 & 7]

FIG.6



FIG.7



12. Install passenger side inner bracket (SEE DIA.2, #2 & #6). Before positioning bracket install the U-nut plate into the frame rail directly across from the factory brake line bracket hole. It may be helpful to hold the exhaust out of your way with a heavy bungee cord or strap pulling it towards the center of the vehicle. Starting forward of the axle, pass the crossmember portion of the bracket up behind and rotate over the top of the exhaust. Move the bracket backward into place. Install bolts in the same orientation as the other side, including the use of the flanged nylock nut in the upper rearward hole of the bracket. [FIGURE 8 & 9]



FIG.8



FIG.9

13. Install (2) 1/2" x 1.5" bolts with washers down the 2 remaining lower holes through the inner and outer brackets, slide the tension plates up underneath. Retain with nylock nuts. Do not tighten.

14. Install the billet aluminum crossmember (SEE DIA.2, #2 & #9) between the inner brackets using (4) 1/2" x 2.75" bolts, washers and nylock nuts. Do not tighten.

15. Now that all the bolts have been started you can start the tightening procedure. First tighten the outer brackets to the frame with the factory center lower bolt and the (2) outside bolts that go into the nut plate. Go back and forth between the bolts to remove the slack evenly. Tighten the lower bolt to 30 ft-lbs and the side bolts to 54 ft-lbs. Now tighten the (4) lower bolts (2 vertical and 2 horizontal) going back and forth between them to take up the slack evenly. [Torque to 78 ft-lbs]. Tighten the last 2 upper bolts to 78 ft-lbs.

16. The crossmember is mounted with slotted holes. Center it left to right and tighten the (4) bolts to 78 ft-lbs.

17. Assemble the tension strut bars. The rod ends are left hand thread and the clevis is right hand thread. Spin the jam nuts up the shank, note left and right hand thread. Install into the tension rod, there is a notch on the bar to indicate the left hand threaded end.

18. Install the strut rod center plates to the crossmember with (2) 1/2" x 2.75" bolts, washers, and nylock nuts. Install the rod ends of the tension rods between the center plates with 1/2" x 2.75" bolts, washers, and nylock nuts and three additional washers. One between the rod ends and one between each rod end and the plates. Tighten the two upper bolts to 78 ft-lbs.

19. Reinstall the exhaust hangers. It is common for the rubber in the hangers to fatigue over time so it may be necessary to bend the rods that go through the hangers to position the exhaust higher for adequate clearance of the strut rods. [FIGURE 10]



FIG.10



FIG.11

NOTE: On some trucks it may also be beneficial to position the exhaust rearward a bit. Loosen the clamp rearward of the resonator and flange forward of the resonator. Rotate the resonator slightly to disengage the locking pin [FIGURE 11]. Slide the back half of the exhaust out of the junction to the resonator to optimize exhaust clearance.

NOTE: Use of aftermarket exhaust may require custom fabrication to allow clearance of tension rods.

20. Adjust tension rods to line up the hole in the clevis with the tension plates on the brackets. Install 3/8" bolts, washers, and nuts in the clevis - do not tighten. Adjust the tension rods to take out all of the slack, make sure they are pulling (towards the center of the vehicle), not pushing. With the slack removed from each side tighten each rod an additional 1/2 turn to pretension and stabilize the bracketry system then tighten the jam nuts. Torque the 3/8" bolts to 45 ft-lbs.

21. Install the bump stops. Slide the 1" spacer ring over the bump stop (unless you are using ICON RXT shocks/leaf springs, then do not use the spacer). Slide the bump stop up into the mount, install the 1/4" bolts and nuts in the mount can pinch tubes and tighten. Do not overtighten the pinch bolts or the bump stop could bind, causing it to not fully extend. Installation of spacer ring is mandatory to limit suspension compression, unless using ICON RXT rear shocks/leaf springs. [FIGURE 12]



FIG.12



FIG.13

22. Install the striker pads (See DIA.2, #7) on the axle tube. The lower portion of the striker plate hooks under the leaf spring pad on the axle. Install u-bolt up under the axle and through the pad and secure with 3/8" nylock nuts and washers. Tighten until the pad is in full contact with the axle tube but do not over tighten. [FIGURE 13]

NOTE: Due to slight variances in factory tolerances, OE U-bolts may be too close to axle housing to allow striker plate fitment. If this occurs, factory U-bolts may need to be loosened slightly to allow for installation. Re-torque to factory specifications.

23. Secure brake lines and wires. Re-insert all of the clips on the inside driver's side frame rail. The new bracket has all the same holes as the frame rail to replace everything back to the original position. Secure the brake line bracket using the original 8mm bolt through the inner bracket and into the factory nut plate.

24. Reinstall wheels and lower vehicle back to the ground. [Torque lugs to factory spec] Reinstall spare tire.

VERIFY ALL FASTENERS ARE PROPERLY TORQUED BEFORE DRIVING VEHICLE.

RETORQUE ALL NUTS, BOLTS AND LUGS AFTER 100 MILES AND PERIODICALLY THEREAFTER.

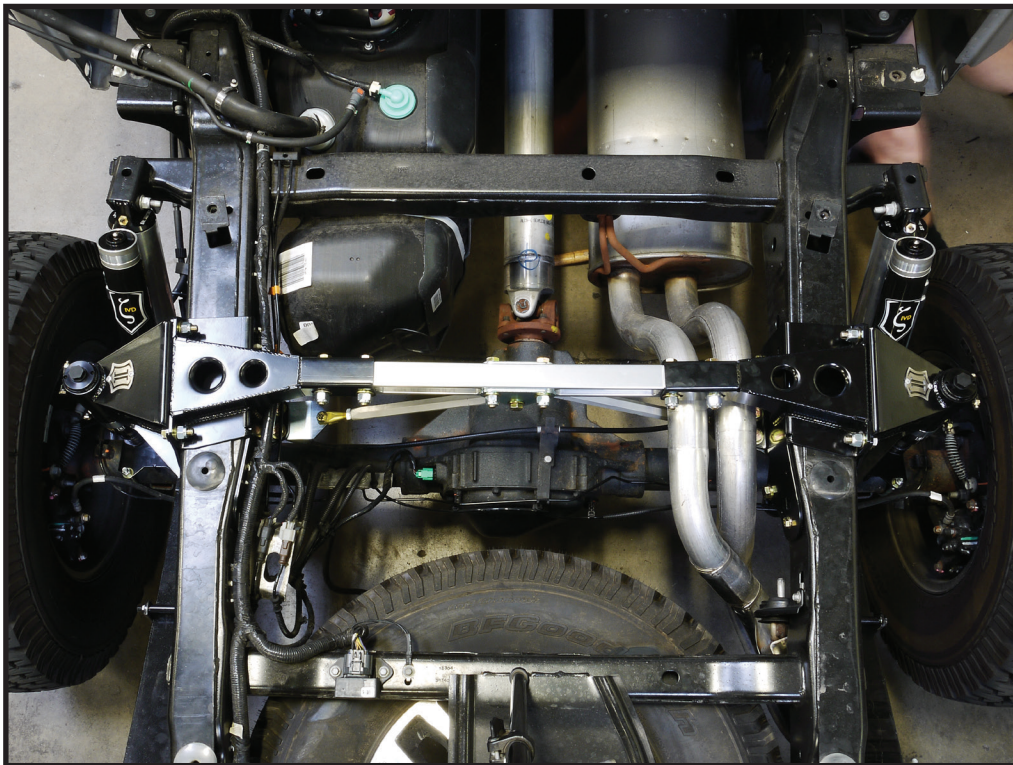

DIA.1

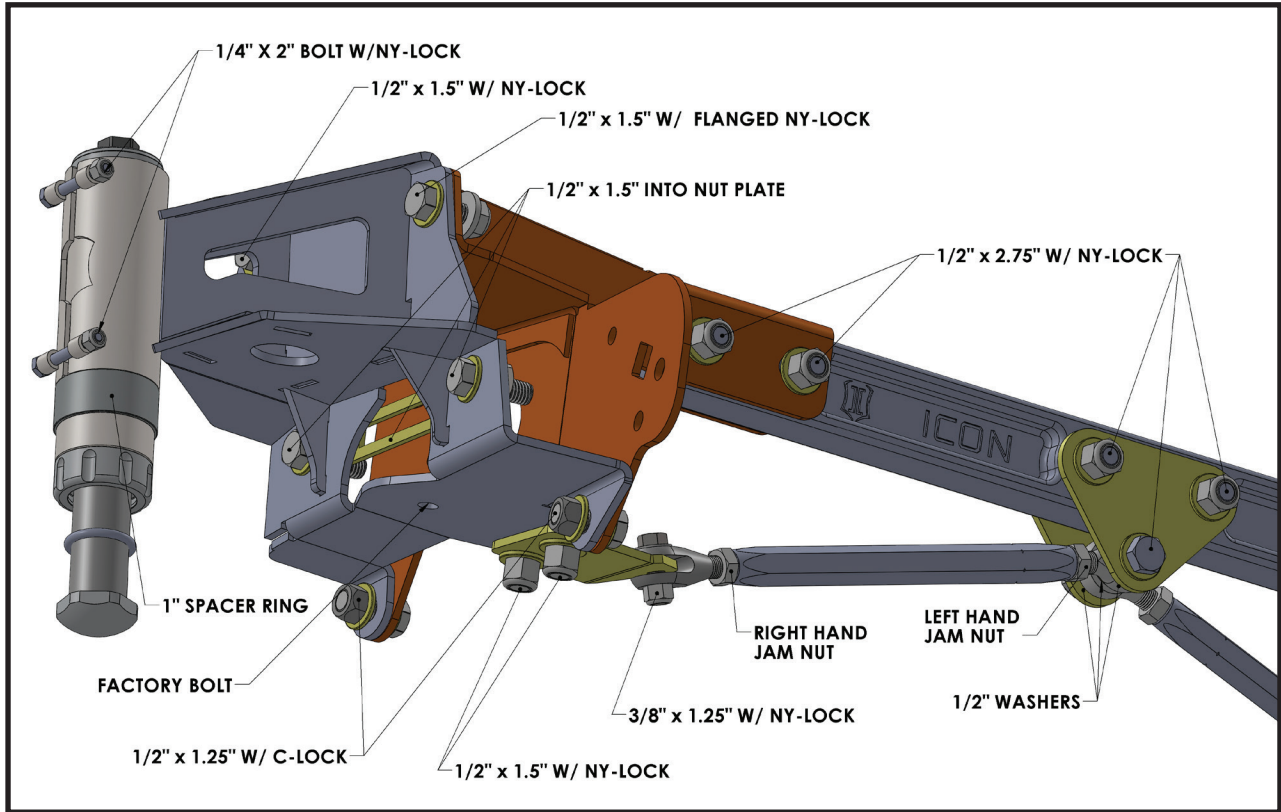

DIA.2

ITEM NO.	PART NUMBER	DESCRIPTION	QTY
1	190005	RAPTOR RR BUMP STRUT TAB	2
2	190006	RAPTOR RR BUMP STRUT MID PLATE	2
3	194005	10+ RAPTOR RR AIR BUMP MNT DRVR	1
4	194006	10+ RAPTOR RR AIR BUMP MNT PASS	1
5	194008	RAPTOR AIR BUMP MNT INSIDE DRVR	1
6	194009	RAPTOR AIR BUMP MNT INSIDE PASS	1
7	194010	RAPTOR RR BUMP STRIKER PLATE	2
8	194011	RAPTOR RR BUMP NUT PLATE	2
9	197015	10+ RAPTOR AIR BUMP CROSS BAR	1
10	197016	10+ RAPTOR AIR BUMP TENSION ROD	2
12	204907	2.0 AIR BUMP 2.5 TRAVEL 1:1 HD	2
13	95120H	10+ RAPTOR AIR BUMP HARDWARE KIT	1

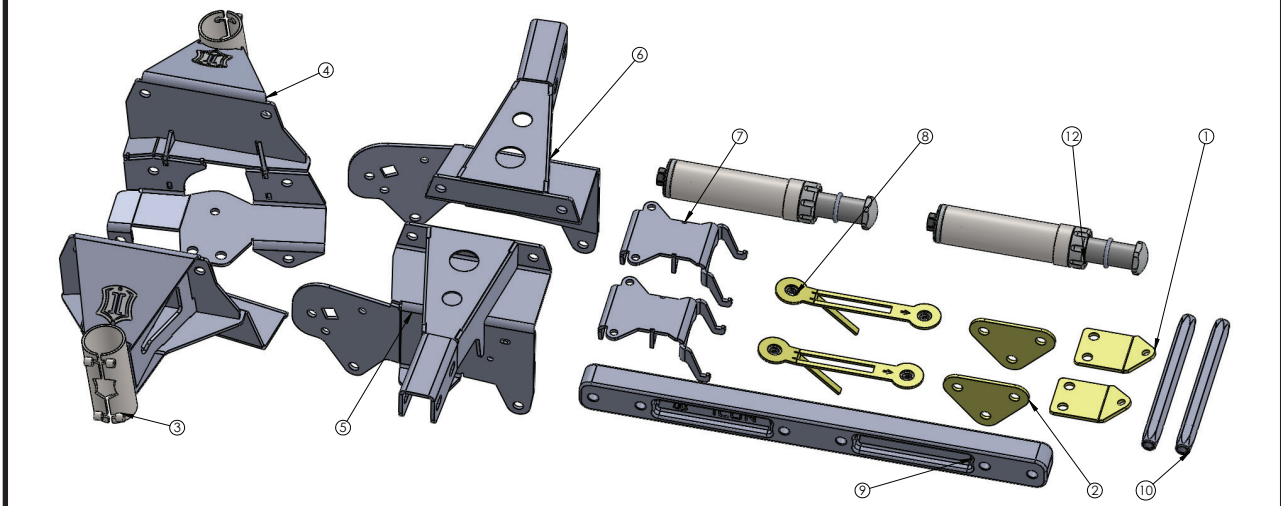

2.0 BUMP STOP TECHNICAL INFORMATION

MAINTENANCE

ICON shock absorbers are a high quality rebuildable race style shock absorber designed for optimal performance. With a unit of this caliber on your vehicle, routine maintenance is required to keep them looking and operating in like new condition. Residual oil and assembly lube may be present at all seal paths from the factory out of the box and is considered normal. Pooling of oil however is not acceptable at any time and one should contact the ICON dealer where purchased.

BELOW ARE GUIDELINES BASED ON HOW YOU USE YOUR VEHICLE BUT YOUR MILEAGE MAY VARY:

STREET USE:

- Send in for factory servicing every 40,000 miles or if a leak develops, ride quality decreases, or they begin to make excessive noise.
- Remove any buildup of road salt, mud, or debris from shocks anytime accrued
- Clean with mild soap and water with each oil change or anytime you notice build up.
- Wax the cylinders yearly with automotive wax to prevent corrosion.
- Check nitrogen pressure yearly. (252004 charge needle assembly available at any ICON distributor)

STREET/DIRT:

- Send in for factory servicing every 15,000 miles or if a leak develops, ride quality decreases, or they begin to make excessive noise.
- Clean with mild soap and water with each oil change, offroad trip, or anytime you notice build up.
- Wax the cylinders yearly with automotive wax to prevent corrosion.
- Check nitrogen pressure each dirt outing. (252004 charge needle assembly available at any ICON distributor)

DIRT USE:

- Send in for factory servicing every 1,000 miles.
- Check nitrogen pressure each outing. (252004 charge needle assembly available at any ICON distributor)
- Remove any buildup of mud or debris from shocks after every outing.

SELF-SERVICE:

- Contact ICON for service kits & tools at (951) 689-4266.

PRODUCT REGISTRATION

Please visit: <http://www.iconvehicledynamics.com/tech-support/registration/> to register your product.

ICON VEHICLE DYNAMICS SHOCK ABSORBER WARRANTY

This shock absorber has a 1 year warranty against any manufacturer's defects. If a shock fails within the initial year of ownership, the shock must be shipped to ICON Vehicle Dynamics for inspection and service. If a shock is inspected and it has been determined the shock failed due to neglect, damage caused by improper installation or any other reason besides "normal wear and tear", the owner of said shock is responsible for all service costs. This includes labor, parts, and shipping.

ICON Vehicle Dynamics warrants to the original retail purchaser who owns the vehicle on which the product was originally installed. ICON Vehicle Dynamics does not warrant the product for finish, alterations, modifications and/or installation contrary to ICON Vehicle Dynamics instructions. ICON Vehicle Dynamics products are not designed, nor are they intended to be installed on vehicles used in race applications, for racing purposes or for similar activities. (A "race" is defined as any contest between two or more vehicles, or a contest of one or more vehicles against the clock, whether or not such contest is for a prize). This warranty does not include coverage for police or taxi vehicles, race vehicles, or vehicles used for government or commercial purposes. Also excluded from this warranty are sales outside of the United States of America and Canada.

ICON Vehicle Dynamics' obligation under this warranty is limited to the repair or replacement, at ICON Vehicle Dynamics' discretion, of the defective product. Any and all costs of removal, installation or re-installation, freight charges and incidental or consequential damages are expressly excluded from this warranty. Items that are subject to wear are not considered defective when worn and are not covered.

ICON Vehicle Dynamics components must be installed as a complete kit as shown in our current application guide. Any substitutions or exemptions of required components will immediately void the warranty. Some finish damage may happen to parts during shipping and is not covered under warranty.

This warranty is expressly in lieu of all other warranties expressed or implied. This warranty shall not apply to any product that has been improperly installed, modified or customized subject to accident, negligence, abuse or misuse.

To send a shock in for warranty please visit our website <http://www.iconvehicledynamics.com/tech-support/shock-service/>

ICON VEHICLE DYNAMICS LIMITED LIFETIME WARRANTY

ICON Vehicle Dynamics warrants to the original retail purchaser who owns the vehicle on which the product was originally installed. ICON Vehicle Dynamics does not warrant the product for finish, alterations, modifications and/or installation contrary to ICON Vehicle Dynamics instructions. ICON Vehicle Dynamics products are not designed, nor are they intended to be installed on vehicles used in race applications, for racing purposes or for similar activities. (A "race" is defined as any contest between two or more vehicles, or a contest of one or more vehicles against the clock, whether or not such contest is for a prize). This warranty does not include coverage for police or taxi vehicles, race vehicles, or vehicles used for government or commercial purposes. Also excluded from this warranty are sales outside of the United States of America and Canada.

ICON Vehicle Dynamics' obligation under this warranty is limited to the repair or replacement, at ICON Vehicle Dynamics' discretion, of the defective product. Any and all costs of removal, installation or re-installation, freight charges and incidental or consequential damages are expressly excluded from this warranty. Items that are subject to wear are not considered defective when worn and are not covered.

ICON Vehicle Dynamics components must be installed as a complete kit as shown in our current application guide. Any substitutions or exemptions of required components will immediately void the warranty. Some finish damage may happen to parts during shipping and is not covered under warranty.

This warranty is expressly in lieu of all other warranties expressed or implied. This warranty shall not apply to any product that has been improperly installed, modified or customized subject to accident, negligence, abuse or misuse.

7929 Lincoln Ave. Riverside, CA 92504
Phone: 951.689.ICON Fax: 951.689.1016

PART #	DESCRIPTION
95200	10-14 RAPTOR REAR 3.0 PB BYPASS SHOCKS

COMPONENTS INCLUDED	
(1) 194960D 10-14 RAPTOR 3.0 BYPASS (DRVR)	(1) 194960P 10-14 RAPTOR 3.0 BYPASS (PASS)
HARDWARE INCLUDED	
N/A	
TOOLS REQUIRED	
JACK JACK STANDS GRINDER W/ BARREL SANDER	TORQUE WRENCH 15MM SOCKET / WRENCH 18MM SOCKET / WRENCH
TECH NOTES	
<p>1. YOUR ICON SHOCK ASSEMBLIES COME FACTORY CHARGED TO 250 PSI. RELEASING NITROGEN PRESSURE MAY LEAD TO SHOCK MALFUNCTION AND REDUCED RIDE QUALITY. FAILURE CAUSED BY LOW NITROGEN PRESSURE IS NOT COVERED UNDER ICON'S WARRANTY POLICY.</p> <p>2. IF USING AFTERMARKET REAR LEAF SPRINGS, MINOR SANDING OF THE SHOCK MOUNT MAY BE NECESSARY TO ALLOW FOR THE FULL RANGE OF MOTION.</p>	



WARNING!
<p>** READ ALL INSTRUCTIONS THOROUGHLY FROM START TO FINISH BEFORE BEGINNING INSTALLATION! IF THESE INSTRUCTIONS ARE NOT PROPERLY FOLLOWED SEVERE FRAME, SUSPENSION AND TIRE DAMAGE MAY RESULT TO THE VEHICLE!</p> <p>** ICON VEHICLE DYNAMICS RECOMMENDS THAT YOU EXERCISE EXTREME CAUTION WHEN WORKING UNDER A VEHICLE THAT IS SUPPORTED WITH JACK STANDS.</p> <p>** ICON VEHICLE DYNAMICS RECOMMENDS ALL INSTALLATION TO BE PERFORMED BY A PROFESSIONAL SHOP/SERVICE TECHNICIAN. PRODUCT FAILURE CAUSED BY IMPROPER INSTALLATION WILL NOT BE COVERED UNDER ICON'S WARRANTY POLICY.</p>

INSTALLATION

- Using a properly rated jack, raise the rear of the vehicle and support the frame rails with jack stands. Ensure the jack stands are secure and set properly before lowering the jack. NEVER WORK UNDER AN UNSUPPORTED VEHICLE. Remove the rear wheels.
- Using a jack, support the rear axle to relieve the tension from being at full extension.
- Remove the factory rear shocks using a 15mm and 18mm socket/wrench.

4. Minor sanding may be necessary to allow clearance for the top cap of the shock if using aftermarket leaf springs. If applicable, please refer to the attached diagram. Touch up any bare metal with spray paint to prevent corrosion. [FIGURE 1 - 3]

FIG.1

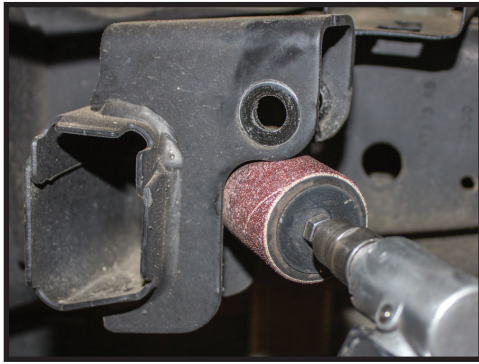

FIG.2



FIG.3



5. Install the ICON rear shocks using a 15mm and an 18mm socket/wrench. Note that the reservoir points away from the axle. [Torque to factory spec]

6. Ensure that the shock reservoir is clocked properly so that it won't make contact with the leaf spring. Check this with the heim spacers clocked towards the frame/leaf spring.

VERIFY ALL FASTENERS ARE PROPERLY TORQUED BEFORE DRIVING VEHICLE.

RETORQUE ALL NUTS, BOLTS AND LUGS AFTER 100 MILES AND PERIODICALLY THEREAFTER.

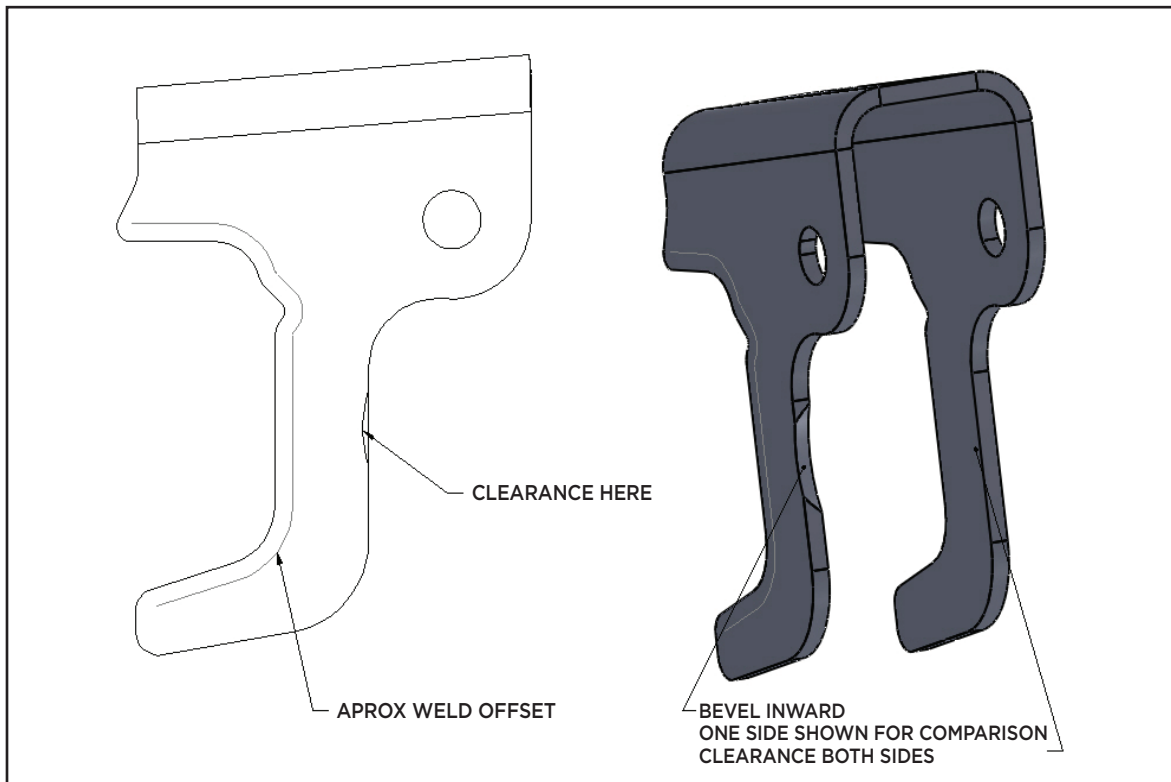

ICON VEHICLE DYNAMICS

PERFORMANCE SUSPENSION SYSTEMS AND SHOCK ABSORBERS

RAPTOR REAR BYPASS FIELD TUNING GUIDE

NITROGEN SETTING

ICON SETTINGS: 220 PSI

COMPRESSION TUBE 1 (SHORT)

ICON SETTINGS: ALL OUT

The short compression tube is designed to tune the “ride zone” specifically. The shocks piston is in this zone while at ride height, so any adjustments on this tube will be felt when street driving. This tube overlaps the long compression tube, therefore the long tube is used to add compression and it will affect the ride zone. The short tube can be used to counter any adjustments made to the long tube.

COMPRESSION TUBE 2 (LONG)

ICON SETTINGS: (4) REVOLUTIONS OUT FROM CLOSED

The long compression tube affects the ride zone and the zone leading into the “bump zone”. This tube starts wide open; closing this tube off will start to affect the ride zone slightly and will start to stiffen the ride quality in the zone right after ride. If the vehicle is bottoming out easily, this tube will help increase the compression sooner and allow the shock to be slowing down more before it reaches the “bump zone”.

REBOUND TUBE

ICON SETTINGS: (4) REVOLUTIONS OUT FROM CLOSED

Rebound control will greatly impair handling. Opening the rebound adjustment will cause the vehicle’s rear end to feel loose and can cause the vehicle’s rear end to “kick” or “buck”. Closing off the rebound adjustment can cause the vehicle to feel like the rear wheels are frozen and the vehicle will become harsh and choppy. The rear end will begin to “pack up” when off-roading and may kick/buck due to the shock bottoming out and not being able to return fast enough to catch the next bump.

SHAFT

Keep an eye to make sure the shaft is clear from knicks/scratches. Small abrasions allow rust to form and eat away the shaft. Keep shafts smooth or damage to the seals can occur.

MOLDED SHIN GUARD

Thick molded shin guard was designed specifically to protect the shaft, rod end, and bearing from pitting, scratches, and road debris. This is a wearable item and should be inspected after each offroad trip.

ICON RAPTOR SHIN GUARD REPLACEMENT, PART #191006

HIGH QUALITY 3/4” BEARINGS (TOP/BOTTOM)

Commercial grade spherical bearings feature woven PTFE liners for smooth operation, but they are susceptible to dirt getting in and damaging the liner. Cleaning these bearings and preventing debris build up will prolong the life of these components.

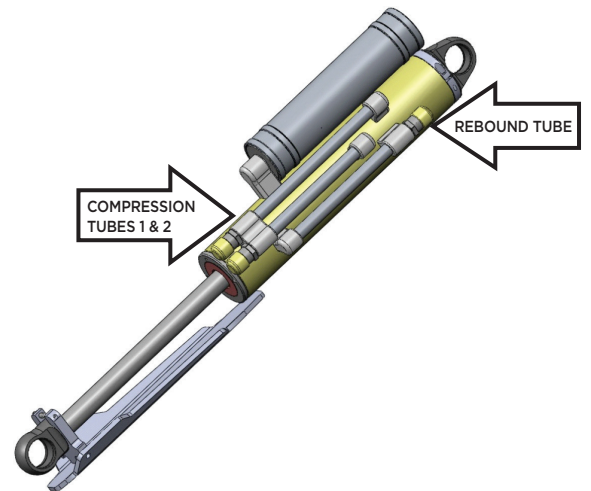

FIELD TUNING GUIDE

COMPRESSION TUBE 1	VALVE ON BOTTOM, THE SHORTER OF THE 2 TUBES. THIS VALVE HAS THE MOST FLOW AND WHEN OPEN ATTRIBUTES TO A SOFT RIDE. CAN BE LEFT MOSTLY OPEN UNLESS CARRYING A HEAVY LOAD. THE MORE ITS OPEN THE FASTER THE WHEEL CAN GO OVER AN OBSTACLE WITHOUT UPSETTING THE VEHICLE WHEN HIT AT SPEED. EFFECTIVE TO 65% OF TRAVEL
COMPRESSION TUBE 2	VALVE ON BOTTOM, THE LONGER OF THE 2 TUBES. THIS VALVE SLOWS DOWN THE WHEEL AS IT GETS CLOSER TO THE BUMP ZONE. WHEN DRIVING AGGRESSIVELY THIS VALVE KEEPS THE WHEEL FROM BLOWING THROUGH THE TRAVEL THE MORE IT IS CLOSED. EFFECTIVE TO 85% OF TRAVEL
REBOUND 2	VALVE ON TOP, INDEPENDENT TUBE. THIS VALVE CONTRIBUTES MOST TO THE OVERALL FEELING OF STABILITY. THE MORE ITS OPEN THE FASTER THE WHEEL CAN FOLLOW THE GROUND WHEN CYCLING QUICKLY. THE MORE ITS CLOSED THE MORE IT HOLDS THE CHASSIS DOWN. GENERALLY HAVING IT OPEN AS MUCH AS POSSIBLE WITHOUT MAKING IT TOO “FLOATY” IS BEST FOR OFF ROAD.

RECOMMENDED SETTINGS

	GENERAL OFFROAD	HIGH SPEED WHOOPS	UNLOADED STREET	LOADED	TOWING
COMP 1	7 (OPEN)*	7 (OPEN)*	7 (OPEN)*	5	4
COMP 2	4	2 - 3	4	3	2
REBOUND	5	5.5 - 7.5	4	3	1.5 - 2

SETTINGS REFERENCE FULL TURNS OUT (COUNTERCLOCKWISE) FROM FULLY CLOSED (CLOCKWISE). (4 CLICKS PER TURN)

*BYPASS VALVE WILL STOP CLICKING AT 6 FULL TURNS OUT, BUT WILL CONTINUE TO TURN ONE MORE REVOLUTION TO FULLY OPEN POSITION.

3.0 VS SERIES SHOCK & COILOVER TECHNICAL INFORMATION

MAINTENANCE

ICON shock absorbers are a high quality rebuildable race style shock absorber designed for optimal performance. With a unit of this caliber on your vehicle, routine maintenance is required to keep them looking and operating in like new condition. Residual oil and assembly lube may be present at all seal paths from the factory out of the box and is considered normal. Pooling of oil however is not acceptable at any time and one should contact the ICON dealer where purchased.

BELOW ARE GUIDELINES BASED ON HOW YOU USE YOUR VEHICLE BUT YOUR MILEAGE MAY VARY:

STREET USE:

- Send in for factory servicing every 40,000 miles or if a leak develops, ride quality decreases, or they begin to make excessive noise.
- Remove any buildup of road salt, mud, or debris from shocks and coil springs anytime accrued
- Clean with mild soap and water with each oil change or anytime you notice build up.
- Wax the cylinders yearly with automotive wax to prevent corrosion.
- Check nitrogen pressure yearly. (252004 charge needle assembly available at any ICON distributor)
- Check bearings for excessive wear yearly.
- **DO NOT** apply any type of lube to the upper and lower bearings.

STREET/DIRT:

- Send in for factory servicing every 15,000 miles or if a leak develops, ride quality decreases, or they begin to make excessive noise.
- Clean with mild soap and water with each oil change, offroad trip, or anytime you notice build up.
- Wax the cylinders yearly with automotive wax to prevent corrosion.
- Check nitrogen pressure each dirt outing. (252004 charge needle assembly available at any ICON distributor)
- Check bearings for excessive wear yearly.
- **DO NOT** apply any type of lube to the upper and lower bearings.

DIRT USE:

- Send in for factory servicing every 1,000 miles.
- Check nitrogen pressure each outing. (252004 charge needle assembly available at any ICON distributor)
- Remove any buildup of mud or debris from shocks and coil springs after every outing.

SELF-SERVICE:

- Contact ICON for service kits & tools at (951) 689-4266.

PRODUCT REGISTRATION

Please visit: <http://www.iconvehicledynamics.com/tech-support/registration/> to register your product.

ICON VEHICLE DYNAMICS SHOCK ABSORBER WARRANTY

This shock absorber has a 1 year warranty against any manufacturer's defects. If a shock fails within the initial year of ownership, the shock must be shipped to ICON Vehicle Dynamics for inspection and service. If a shock is inspected and it has been determined the shock failed due to neglect, damage caused by improper installation or any other reason besides "normal wear and tear", the owner of said shock is responsible for all service costs. This includes labor, parts, and shipping.

ICON Vehicle Dynamics warrants to the original retail purchaser who owns the vehicle on which the product was originally installed. ICON Vehicle Dynamics does not warrant the product for finish, alterations, modifications and/or installation contrary to ICON Vehicle Dynamics instructions. ICON Vehicle Dynamics products are not designed, nor are they intended to be installed on vehicles used in race applications, for racing purposes or for similar activities. (A "race" is defined as any contest between two or more vehicles, or a contest of one or more vehicles against the clock, whether or not such contest is for a prize). This warranty does not include coverage for police or taxi vehicles, race vehicles, or vehicles used for government or commercial purposes. Also excluded from this warranty are sales outside of the United States of America and Canada.

ICON Vehicle Dynamics' obligation under this warranty is limited to the repair or replacement, at ICON Vehicle Dynamics' discretion, of the defective product. Any and all costs of removal, installation or re-installation, freight charges and incidental or consequential damages are expressly excluded from this warranty. Items that are subject to wear are not considered defective when worn and are not covered.

ICON Vehicle Dynamics components must be installed as a complete kit as shown in our current application guide. Any substitutions or exemptions of required components will immediately void the warranty. Some finish damage may happen to parts during shipping and is not covered under warranty.

This warranty is expressly in lieu of all other warranties expressed or implied. This warranty shall not apply to any product that has been improperly installed, modified or customized subject to accident, negligence, abuse or misuse.

To send a shock in for warranty please visit our website <http://www.iconvehicledynamics.com/tech-support/shock-service/>



ICON VEHICLE DYNAMICS®
PERFORMANCE SUSPENSION SYSTEMS AND SHOCK ABSORBERS

7929 Lincoln Ave. Riverside, CA 92504 Phone: 951.689.ICON Fax: 951.689.1016
www.iconvehicledynamics.com



FOLLOW US ON FACEBOOK!

