

## INSTALLATION INSTRUCTIONS

### PARTS LIST:

Qty	Item Description	Qty	Item Description
1	Bumper Base	4	6-1.00mm x 20mm Combo Allen Bolts
1	PS/right Hitch Mounting Bracket	4	6mm Hex Flange Nuts
1	DS/left Hitch Mounting Bracket	1	4mm Allen Wrench
1	PS/right Mounting Bracket (For W/O Hitch)	12	4mm x 15mm Flat Head Self Tapping Screws
1	DS/left Mounting Bracket (For W/O Hitch)	6	Sensor Hole Plugs
1	PS/right Fill in Mesh Panel	6	Sensor Retaining Caps
1	DS/left Fill in Mesh Panel	6	20mm x 10mm Foam Spacers
1	Pedestrian Alert Speaker Bracket	6	15.5mm x 25mm OD x 2mm Foam Washers
2	Plastic Plugs for License Plate	2	Wire Harness Extensions
6	14mm Plastic Retainers	1	Sensor Cover Kit
2	10mm Long Double Bolt Plates	10	200mm Wire Ties
2	10mm Short Double Bolt Plates	8	10mm x 35mm OD x 2.5mm Flat Washers
4	10mm Plastic Retainers	8	10mm Nylon Lock Hex Nuts

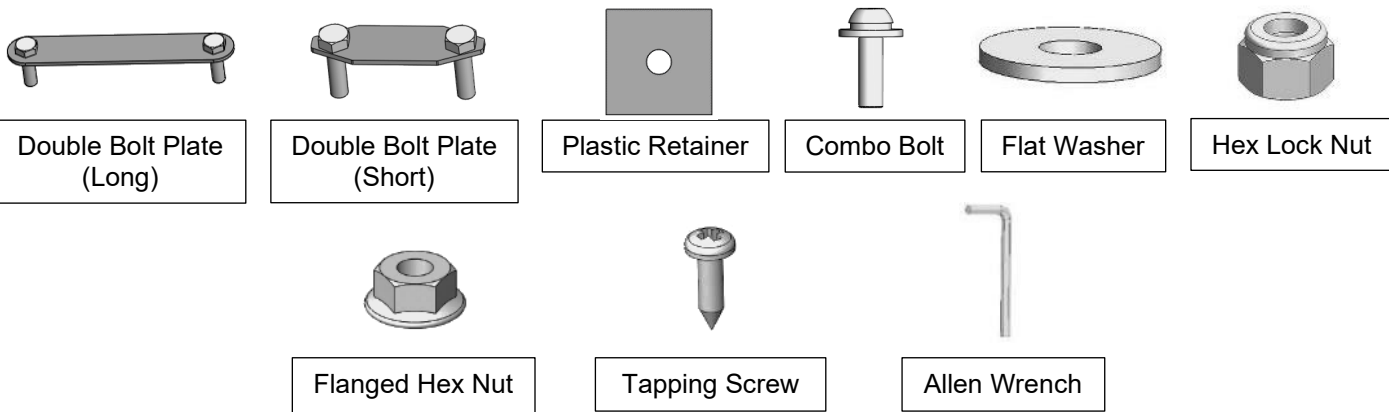
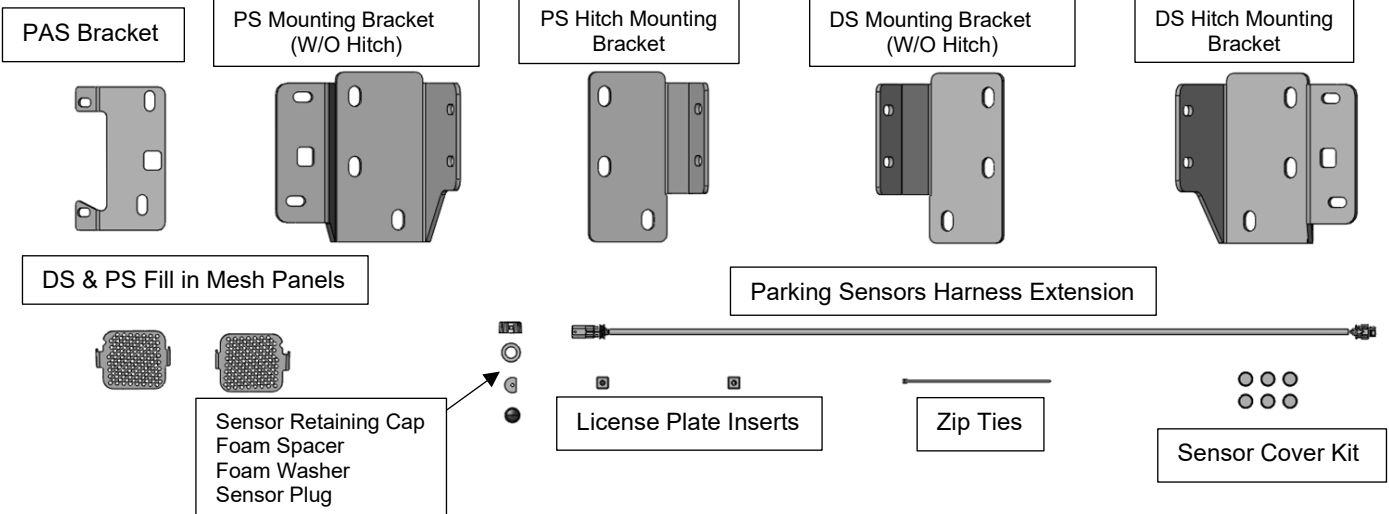
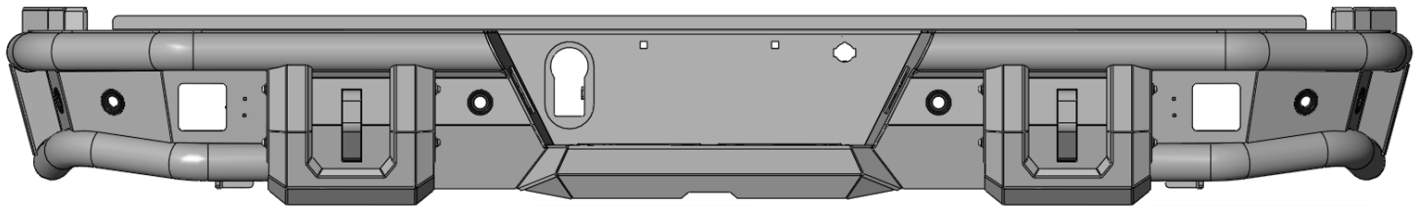

## TOOLS REQUIRED

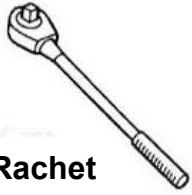

**1** Follow (Fig 1-6) to remove the OEM rear bumper.

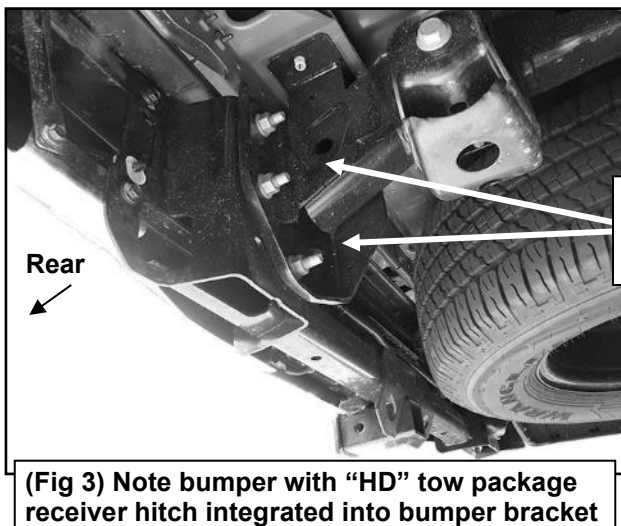

**WARNING!** Do not crawl under bumper unless the bumper is properly supported on blocks or stands or the bumper may fall.

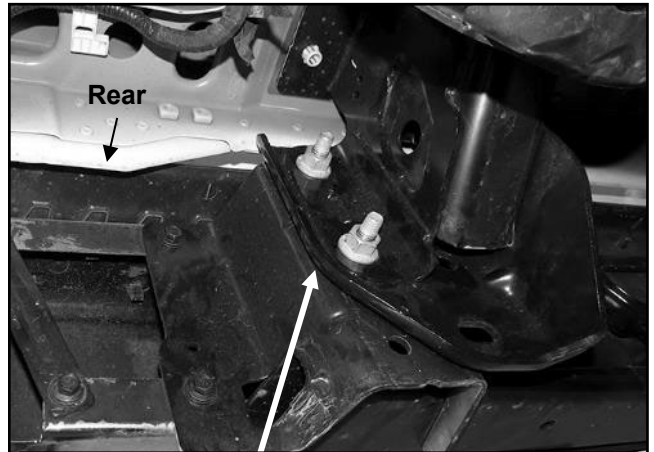

**(Fig 4)** Remove the factory hex nuts attaching bumper assembly to frame. STD tow package model pictured (no receiver hitch)

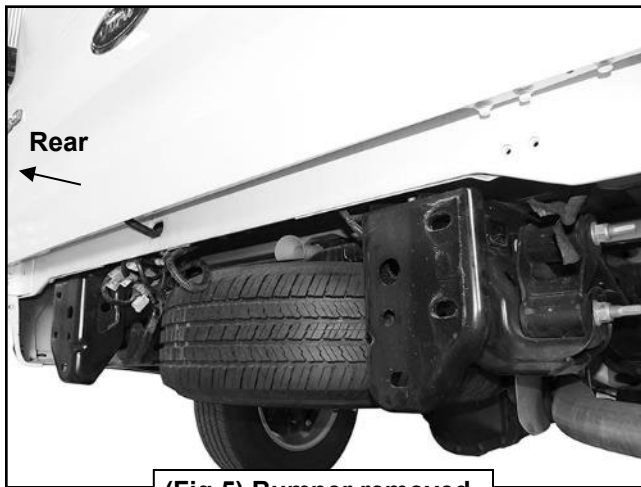

**(Fig 5)** Bumper removed



**(Fig 6)** Disassemble bumper to remove license plate lights, trailer plug, sensors and wiring harness from bumper as equipped

**2** Follow (Fig 7- 11) to swap the OEM rear bumper components to the new bumper.

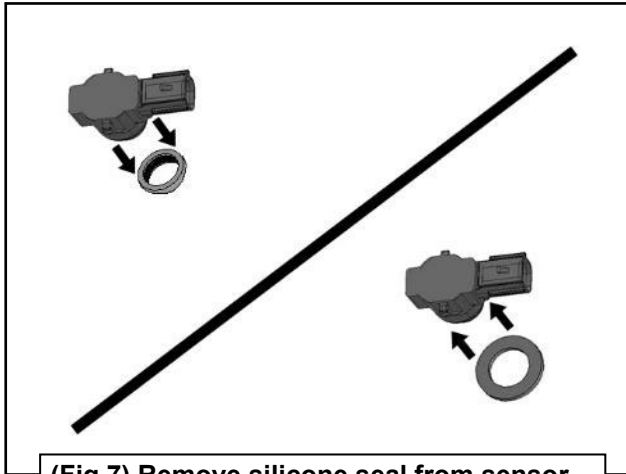

(Fig 7) Remove silicone seal from sensor. Slide large Seal over end of sensor (arrow)

Secure with (2) self-tapping screws

Retaining Cap  
Foam Washer  
Foam Spacer

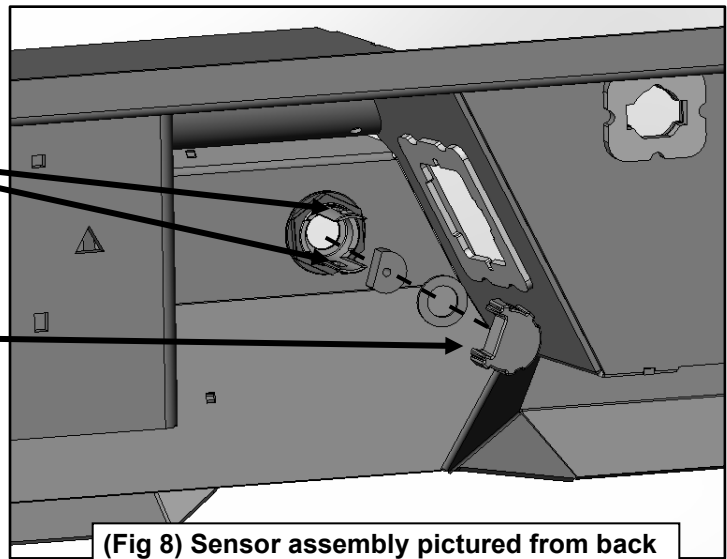

(Fig 8) Sensor assembly pictured from back of bumper

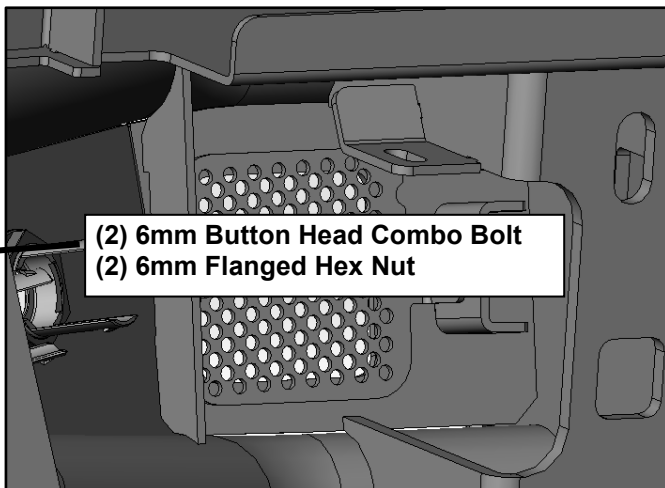

(2) 6mm Button Head Combo Bolt  
(2) 6mm Flanged Hex Nut

(2) 6mm Button Head Combo Bolt  
(2) 6mm Flanged Hex Nut

(2) License Plate Plastic Inserts

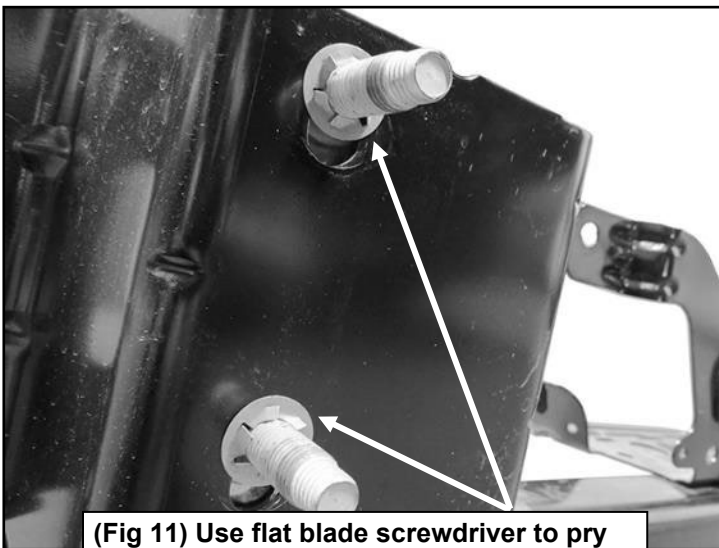
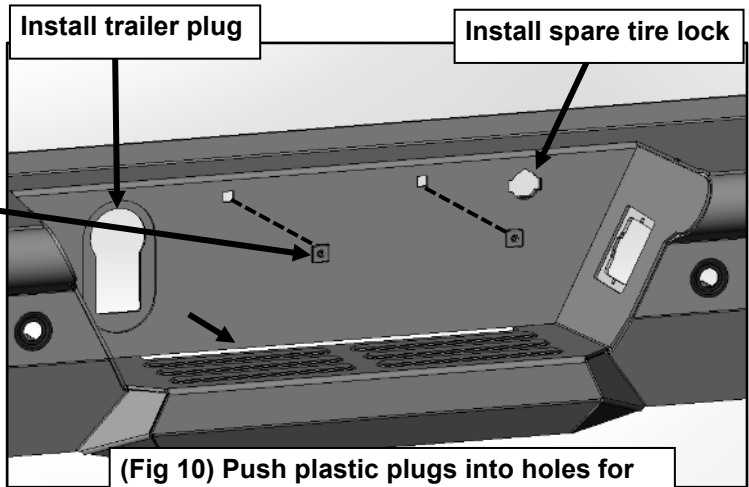

(Fig 11) Use flat blade screwdriver to pry off lock washers from factory bolt plates

And replace OEM lock washers with 14mm plastic retainers

### 3

Follow (Fig 12-19) to install the mounting brackets to the vehicle and to attach the bumper to the mounting brackets.

**Note: Determine whether your vehicle is equipped with a hitch or without a hitch.**

Please use the following mounting brackets for vehicles equipped with a hitch.

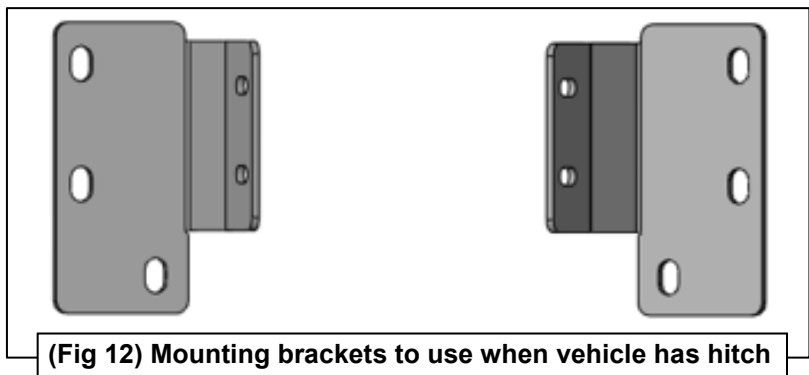

(Fig 12) Mounting brackets to use when vehicle has hitch

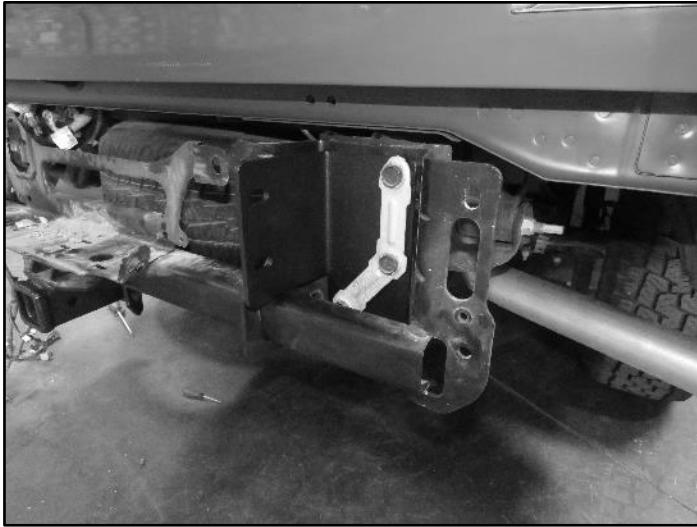

ng

- (2) 10mm Plastic Retainers
- (2) 10mm Flat Washer
- (2) 10mm Lock Nuts
- (1) 10mm Long Bolt Plate

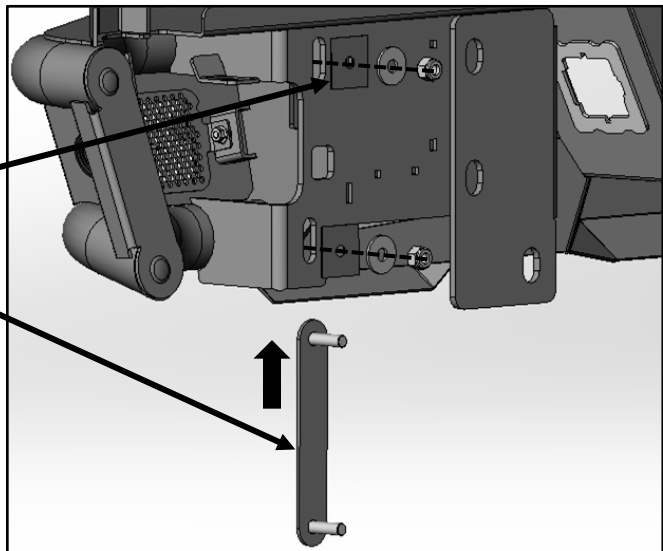

(Fig 14) HW used to mount bumper to hitch

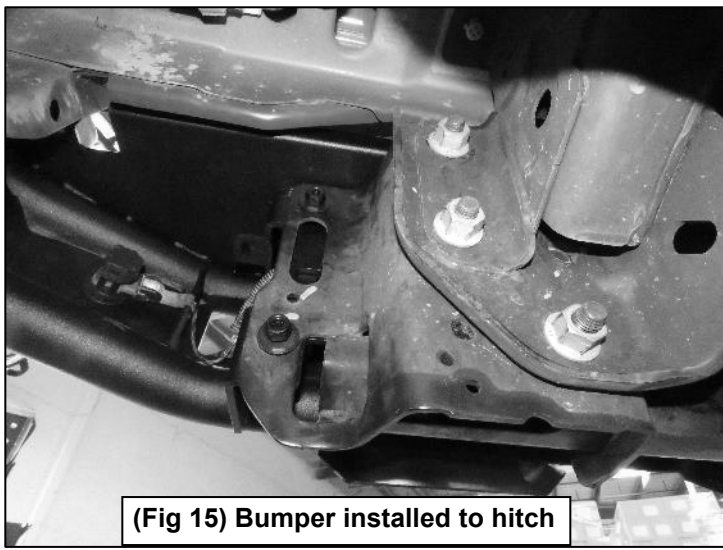

(Fig 15) Bumper installed to hitch

- (2) 10mm Flat Washer
- (2) 10mm Lock Nuts
- (1) 10mm Short Bolt Plate

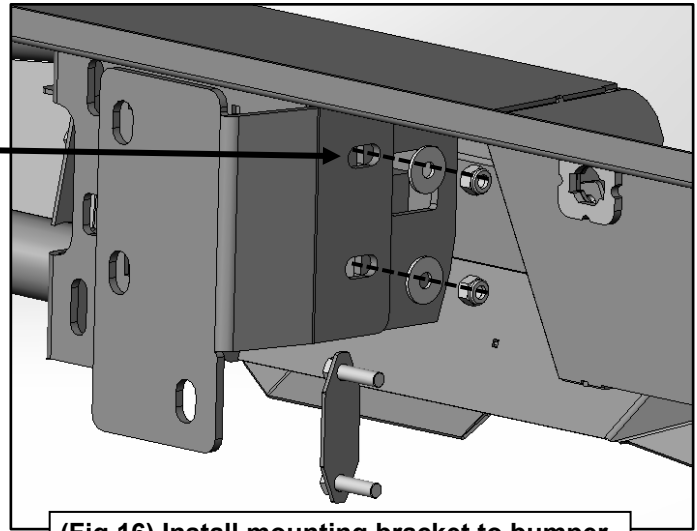

(Fig 16) Install mounting bracket to bumper

If vehicle does NOT come equipped with hitch use the following brackets:

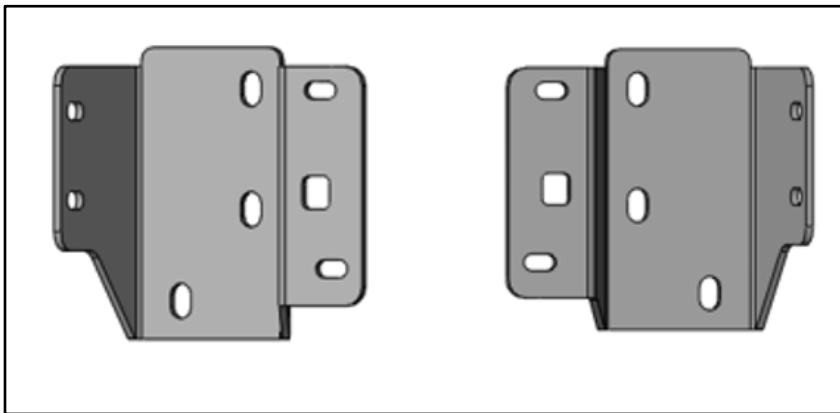

- (2) 10mm Plastic Retainers
- (2) 10mm Flat Washer
- (2) 10mm Lock Nuts
- (1) 10mm Long Bolt Plate

- (2) 10mm Flat Washer
- (2) 10mm Lock Nuts
- (1) 10mm Short Bolt Plate

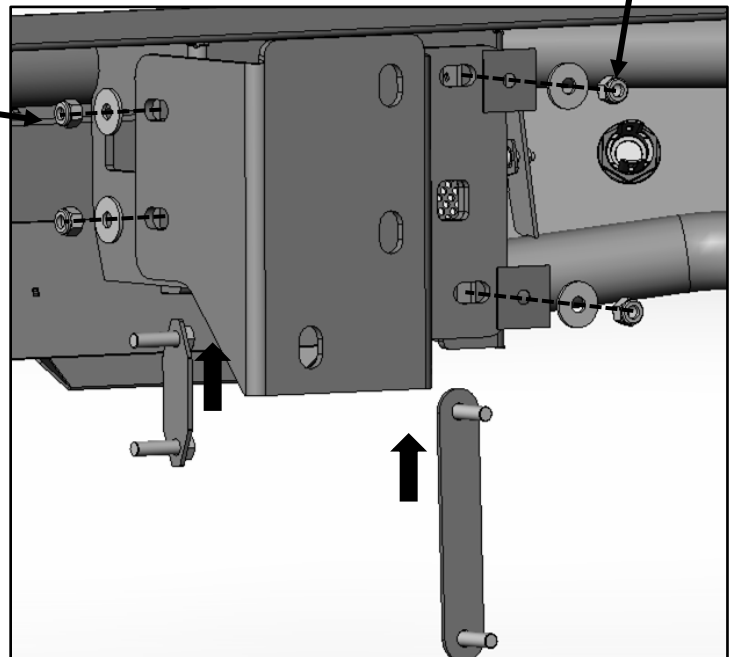

(Fig 18) HW used to mount bumper to mounting brackets

If vehicle is equipped with a Pedestrian Alarm System install PAS bracket:

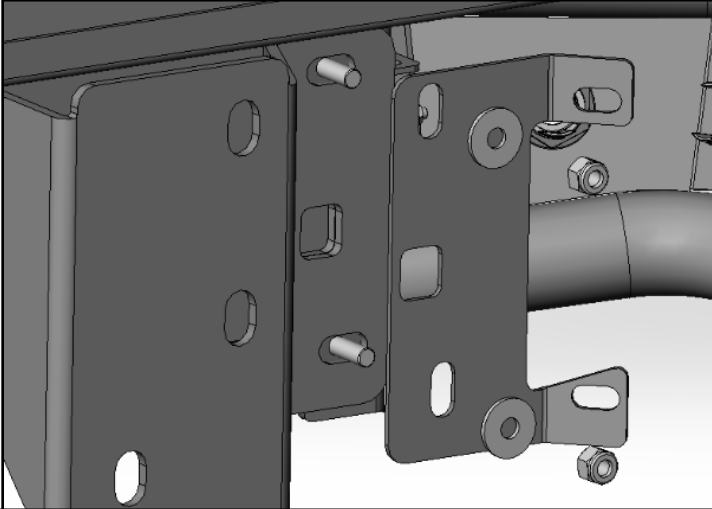

(Fig 19) HW used to mount PAS bracket to mounting brackets

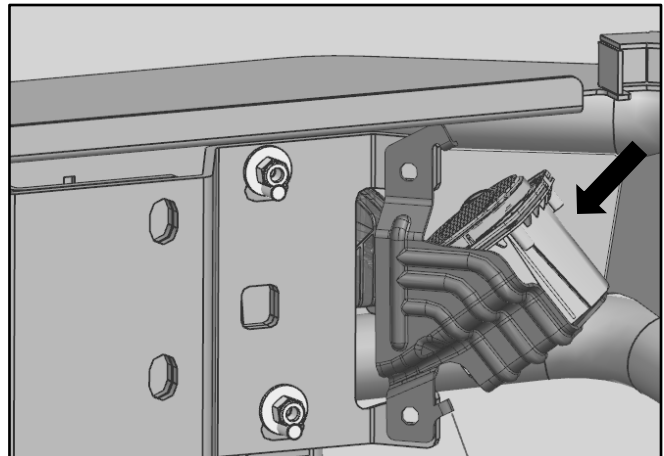

(Fig 20) Install PAS using OEM clip nuts and bolts

**3** Installation is complete do periodic inspections to the installation to make sure that all hardware is secure and tight.

